



# USER MANUAL

## OPERATION & MAINTENANCE MANUAL

### Innovation Water Heaters

Natural Gas and Propane Gas Modulating, Condensing Water heaters

600, 800, 1060, 1400 MBH Water Heaters



#### This Guide Applies to the Following Models:

##### Natural Gas:

- Innovation 600
- Innovation 800
- Innovation 1060
- Innovation 1400

##### Propane:

- Innovation 600P
- Innovation 800P
- Innovation 1060P
- Innovation 1400P

#### Other documents for this product include:

- GF-5030 INN Gas Supply Guide
- GF-5050 INN Venting Guide
- GF-5060 INN Electric Power Guide
- GF-5080 INN Sizing Guide

#### Applies to Serial Numbers:

G-17-2400 and above

U.S. Patent No. 9,243,848

Latest Release: 12/20/2017

**Technical Support**  
1-800-526-0288  
(Mon-Fri, 8am-5pm EST)  
[www.aerco.com](http://www.aerco.com)



#### DISCLAIMER:

The information contained in this manual is subject to change without notice from AERCO International, Inc. AERCO makes no warranty of any kind with respect to this material, including, but not limited to, implied warranties of merchantability and fitness for a particular application. AERCO International is not liable for errors appearing in this manual, nor for incidental or consequential damages occurring in connection with the furnishing, performance, or use of these materials

# TABLE OF CONTENTS

**FOREWORD** ..... 7

**CHAPTER 1. SAFETY PRECAUTIONS** ..... 11

1.1 WARNINGS & CAUTIONS..... 11

1.2 EMERGENCY SHUTDOWN ..... 12

1.3 PROLONGED SHUTDOWN ..... 12

**CHAPTER 2. INSTALLATION** ..... 13

2.1 INTRODUCTION..... 13

2.2 RECEIVING THE UNIT ..... 13

2.3 UNPACKING..... 13

2.4 SITE PREPARATION ..... 14

    2.4.1 Installation Clearances ..... 14

    2.4.2 Setting the Unit ..... 15

2.5 WATER INLET AND OUTLET PIPING..... 16

    2.5.1 WHM Actuator-Controlled Ball Valve Installation ..... 17

2.6 TEST HOSE BIB CONNECTION ..... 18

2.7 INTERNAL RECIRCULATION LOOP..... 19

2.8 PRESSURE & TEMPERATURE RELIEF VALVE INSTALLATION ..... 20

2.9 CONDENSATE DRAIN & PIPING ..... 20

2.10 GAS SUPPLY PIPING ..... 22

    2.10.1 Gas Supply Specifications..... 23

    2.10.2 Manual Gas Shutoff Valve ..... 23

    2.10.3 External Gas Supply Regulator ..... 24

2.11 AC ELECTRICAL POWER WIRING..... 25

    2.11.1 Electrical Power Requirements ..... 26

2.12 FIELD CONTROL WIRING ..... 27

    2.12.1 OUTDOOR AIR IN Terminal..... 28

    2.12.2 COMBUSTION AIR Terminals..... 28

    2.12.3 O2 SENSOR Terminals ..... 28

    2.12.4 SPARK SIGNAL Terminals..... 28

    2.12.5 ANALOG IN Terminals ..... 29

    2.12.6 VALVE FEEDBACK Terminals..... 29

    2.12.7 SHIELD Terminals..... 29

    2.12.8 ANALOG OUT Terminals ..... 29

    2.12.9 RS485 Comm Terminals ..... 30

    2.12.10 RS232 Comm Terminals ..... 30

    2.12.11 VFD/BLOWER Terminals..... 30

    2.12.12 Interlock Terminals..... 30

    2.12.13 FAULT RELAY Terminals..... 31

    2.12.14 AUX RELAY Terminals ..... 31

2.13 FLUE GAS VENT INSTALLATION..... 31

2.14 COMBUSTION AIR..... 32

    2.14.1 Combustion From Outside the Building ..... 32

    2.14.2 Combustion Air from Inside the Building ..... 32

2.15 DUCTED COMBUSTION .....32

**CHAPTER 3. OPERATION .....33**

3.1 INTRODUCTION.....33

3.2 CONTROL PANEL DESCRIPTION.....33

3.3 CONTROL PANEL MENUS .....37

    3.3.1 Menu Processing Procedure .....37

3.4 OPERATING MENU .....39

3.5 SETUP MENU .....40

3.6 CONFIGURATION MENU.....40

3.7 TUNING MENU.....43

3.8 CALIBRATION MENU.....44

3.9 START SEQUENCE .....46

3.10 START/STOP LEVELS .....49

**CHAPTER 4. INITIAL START-UP.....51**

4.1 INITIAL START-UP REQUIREMENTS.....51

4.2 TOOLS AND INSTRUMENTATION FOR COMBUSTION CALIBRATION.....51

    4.2.1 Required Tools & Instrumentation.....52

    4.2.2 Installing Gas Supply Manometer .....52

    4.2.3 Accessing the Analyzer Probe Port.....53

    4.2.4 Connecting Multimeter to Flame Detector.....53

    4.2.5 Recommendations for Temperature Calibration .....54

    4.2.6 Recommendations for WHM Operation .....54

4.3 NATURAL GAS COMBUSTION CALIBRATION .....55

4.4 PROPANE COMBUSTION CALIBRATION .....58

4.5 REASSEMBLY .....60

4.6 TEMPERATURE CONTROL CALIBRATION .....61

    4.6.1 Setting the Outlet Water Temperature Setpoint .....61

    4.6.2 Minimum Load Adjustment.....62

    4.6.3 Maximum Load Adjustment.....62

4.7 OVER-TEMPERATURE LIMIT SWITCHes .....64

**CHAPTER 5. SAFETY DEVICE TESTING.....65**

5.1 INTRODUCTION.....65

5.2 LOW GAS PRESSURE FAULT TEST.....65

5.3 HIGH GAS PRESSURE FAULT TEST .....66

5.4 LOW WATER LEVEL FAULT TEST.....67

5.5 WATER TEMPERATURE FAULT TEST .....67

5.6 INTERLOCK TESTS .....68

    5.6.1 Remote Interlock.....68

    5.6.2 Delayed Interlock .....69

5.7 FLAME FAULT TESTs .....69

5.8 AIR FLOW FAULT TESTS .....70

5.9 SSOV PROOF OF CLOSURE SWITCH .....72

5.10 PURGE SWITCH OPEN DURING PURGE.....73

5.11 IGNITION SWITCH OPEN DURING IGNITION.....73

5.12 SAFETY PRESSURE RELIEF VALVE TEST ..... 74

**CHAPTER 6. MAINTENANCE..... 75**

6.1 MAINTENANCE SCHEDULE ..... 75

6.2 IGNITER-INJECTOR ..... 76

6.3 FLAME DETECTOR ..... 78

6.4 COMBUSTION CALIBRATION ..... 78

6.5 SAFETY DEVICE TESTING ..... 78

6.6 FIRESIDE INSPECTION..... 79

6.7 WATERSIDE PORT INSPECTION ..... 83

6.8 WATERSIDE HEAT EXCHANGER INSPECTION AND CLEANING ..... 84

    6.8.1 HEAT EXCHANGER CLEANING ..... 86

6.9 CONDENSATE DRAIN TRAP ..... 89

6.10 AIR FILTER REPLACEMENT ..... 90

6.11 LOW WATER CUTOFF (LWCO) CAPACITOR INTEGRITY TEST ..... 91

    6.11.1 Low Water Cutoff (LWCO) - Capacitor Electrical Short Test ..... 91

    6.11.2 Low Water Cutoff (LWCO) - Standard C-More Test ..... 93

6.12 SHUTTING THE WATER HEATER DOWN FOR AN EXTENDED PERIOD OF TIME ..... 93

6.13 PLACING THE HEATER BACK IN SERVICE AFTER A PROLONGED SHUTDOWN ..... 94

6.14 SPARK MONITOR (AC CURRENT TRANSDUCER) ..... 94

**CHAPTER 7. TROUBLESHOOTING GUIDE..... 95**

7.1 INTRODUCTION..... 95

7.2 ADDITIONAL FAULTS WITHOUT SPECIFIC FAULT MESSAGES ..... 107

**CHAPTER 8. WATER HEATER MANAGEMENT ..... 111**

8.1 GENERAL DESCRIPTION..... 111

8.2 WHM PRINCIPLES OF OPERATION ..... 112

8.3 NEW AERCO WHM FEATURES ..... 112

    8.3.1 Valve Feedback..... 112

    8.3.2 Valve Supervisor ..... 112

    8.3.3 Valve Control ..... 112

    8.3.4 Modbus Header Sensor ..... 113

    8.3.5 Automatic Temperature Sensor Calibration ..... 113

    8.3.6 Manual Mode Password Required ..... 113

    8.3.7 WHM Auto Mstr ..... 113

    8.3.8 Run Hours and Run Cycles..... 114

    8.3.9 High Temperature Governor ..... 114

8.4 WHM STATUS DISPLAYS..... 114

8.5 WATER HEATER MANAGEMENT ALTERNATING STATUS DISPLAYS..... 115

8.6 WHM MENU ..... 116

8.7 WHM MENU ITEM DESCRIPTIONS..... 118

8.8 WHM HARDWARE INSTALLATION & SET-UP INSTRUCTIONS ..... 122

    8.8.1 Installation Notes ..... 122

    8.8.2 Hardware Installation..... 123

    8.8.3 WHM Modbus Network Wiring..... 124

    8.8.4 Control and Power Wiring..... 125



8.9 WHM PROGRAMMING & START-UP .....	126
8.10 TROUBLESHOOTING .....	128
8.11 SEQUENCING VALVE DESCRIPTION & OPERATION .....	129
8.11.1 Sequencing Valve Description .....	129
8.11.2 Sequencing Valve Operating Characteristics.....	131
APPENDIX A – Innovation Menu Item Descriptions .....	133
Table A-1: Operating Menu Item Descriptions.....	133
Table A-2: Setup Menu Item Descriptions .....	134
Table A-3: Configuration Menu Item Descriptions .....	135
Table A-4: Tuning Menu Item Descriptions .....	138
Table A-5: Calibration Menu Item Descriptions .....	140
APPENDIX B – Startup, Status And Fault Messages.....	143
APPENDIX C – Temperature Sensor Resistance/Voltage Chart.....	147
APPENDIX D – Dimensional Drawings .....	149
APPENDIX E – Parts List Drawings.....	151
APPENDIX F – Piping Drawings .....	167
APPENDIX G – C-More Control Panel Views.....	177
APPENDIX H – C-More Wiring Diagrams .....	179
APPENDIX I – Recommended Spares.....	187
APPENDIX J – Warranty.....	189

(This Page Is Intentionally Blank)

**FOREWORD**

The AERCO Innovation Series Potable Water Heaters are tankless modulating units which represent a true industry advance that meets the needs of today's energy efficiency and environmental concerns. Innovation's compact size and robust venting capabilities allow maximum installation flexibility. The Innovation Series Heaters, with their load tracking controls can modulate up to 30:1 turn down ratio to match the system demand and yield high thermal efficiencies.

Innovation Water Heaters are available in four (4) different sizes ranging from 600,000 BTU/Hr. (175.8 kW) input to 1,350,000 BTU/Hr. (395.6 kW) input; available models are listed below.

<b>TABLE F1: INNOVATION POTABLE WATER HEATER MODELS</b>		
<b>Innovation Models</b>	<b>Description</b>	<b>Shipping Weight</b>
INN600 INN600P	Innovation Potable Water Heater, 600,000 BTU/Hr. (175.8 kW) Input, with Natural Gas or Propane Gas Train	1,060 lbs. (480.8 kg.)
INN800 INN800P	Innovation Potable Water Heater, 800,000 BTU/Hr. (234.5 kW) Input, with Natural Gas or Propane Gas Train	1,080 lbs. (489.9 kg.)
INN1060 INN1060P	Innovation Potable Water Heater, 1,060,000 BTU/Hr. (310.7 kW) Input, with Natural Gas or Propane Gas Train	1,100 lbs. (499.0 kg.)
INN1400 INN1400P	Innovation Potable Water Heater, 1,400,000 BTU/Hr. (410.3 kW) Input, with Natural Gas or Propane Gas Train	1,150 lbs. (521.6 kg.)

All Innovation Heater sizes include Water Heater Management (WHM) software, which is built into each unit's C-More Controller. When the heater is ordered with a Sequencing Valve (SV), up to eight (8) Innovation Water Heaters can be controlled by the WHM system utilizing RS485 Modbus protocol. Units can be ordered with or without Sequencing Valves.

Whether used in singular or modular arrangements, Innovation Water Heaters offer the maximum flexibility in venting with minimum installation space requirements. Innovation's advanced electronic controls offer simplified integration with today's Energy Management Systems.

For service or parts, contact your local sales representative or AERCO International, Inc.

**IMPORTANT!**

Unless otherwise specified, the descriptions and procedures provided in this Installation, Operation & Maintenance Manual apply to all Innovation Series Water Heaters.

# Innovation Installation, Operation & Maintenance – KOREA EDITION

## FORWARD

Phrases, abbreviations and acronyms used in this manual are listed in the following table:

<b>AERCO Technical Terminology Meanings</b>	
<b>TERMINOLOGY</b>	<b>MEANING</b>
A (Amp)	Ampere
ADDR	Address
AGND	Analog Ground
ALRM	Alarm
ANSI	American National Standards Institute
ASME	American Society of Mechanical Engineers
AUX	Auxiliary
BAS	Building Automation System, often used interchangeably with EMS (see below)
Baud Rate	Symbol rate, or simply the number of distinct symbol changes (signaling events) transmitted per second. It is not equal to bits per second, unless each symbol is 1 bit long.
BLDG (Bldg)	Building
BTU	British Thermal Unit. A unit of energy approximately equal to the heat required to raise 1 pound (0.45 kg) of water 1° F (0.55 ° C).
BTU/Hr.	BTUs per Hour (1 BTU/Hr. = 0.29 W)
C-More Controller	A control system developed by AERCO and used in all Benchmark, Innovation and KC1000 Series product lines.
CO	Carbon Monoxide
COMM (Comm)	Communication
Cal.	Calibration
CNTL	Control
CPU	Central Processing Unit
DBB	Double Block and Bleed, a gas trains containing 2 Safety Shutoff Valves (SSOVs) and a solenoid operated vent valve.
DIP	Dual In-Line Package, a type of switch
EMS	Energy Management System; often used interchangeably with BAS
FM	Factory Mutual. Used to define gas trains.
FRU	Field Replacement Unit
GF-xxxx	Gas Fired (an AERCO document numbering system)
GND	Ground
GPH	Gallons per Hour
HX	Heat Exchanger
Hz	Hertz (Cycles Per Second)
I.D.	Inside Diameter
IGN	Ignition

<b>AERCO Technical Terminology Meanings</b>	
<b>TERMINOLOGY</b>	<b>MEANING</b>
IGST Board	Ignition/Stepper Board, contained in C-More Controller
INN	Innovation Water Heater
I/O	Input/Output
I/O Box	Input/Output (I/O) Box currently used on Benchmark, Innovation and KC1000 Series products
IP	Internet Protocol
IRI	Industrial Risk Insurers. Used to define gas trains containing two SSOVs and a solenoid operated vent valve (See DBB above)
ISO	International Organization for Standardization
Lbs.	Pounds (1 lb. = 0.45 kg)
LED	Light Emitting Diode
LN	Low Nitrogen Oxide
MA (mA)	Milliamperes (1 thousand <sup>th</sup> of an ampere)
MAX (Max)	Maximum
MIN (Min)	Minimum
Modbus®	A serial, half-duplex data transmission protocol developed by AEG Modicon
NC (N.C.)	Normally Closed
NO (N.O.)	Normally Open
NOx	Nitrogen Oxide
NPT	National Pipe Thread
O <sub>2</sub>	Oxygen
O.D.	Outside Diameter
OMM	Operation and Maintenance Manual
OnAER	AERCO's on-line remote system monitoring system
PCB	Printed Circuit Board
PMC Board	Primary Micro-Controller (PMC) board, contained in the C-More
P/N	Part Number
PPM	Parts per Million
PSI	Pounds per Square Inch (1 PSI = 6.89 kPa)
PTP	Point-to-Point (usually over RS232 networks)
P&T	Pressure and Temperature
ProtoNode	Hardware interface between BAS and a boiler or water heater
PVC	Poly Vinyl Chloride, a common synthetic plastic
PWM	Pulse Width Modulation
RES.	Resistive

<b>AERCO Technical Terminology Meanings</b>	
<b>TERMINOLOGY</b>	<b>MEANING</b>
RS232 (or EIA-232)	A standard for serial, full-duplex (FDX) transmission of data based on the RS232 Standard
RS422 (or EIA-422)	A standard for serial, full-duplex (FDX) transmission of data based on the RS422 Standard
RS485 (or EIA-485)	A standard for serial, half-duplex (HDX) transmission of data based on the RS485 Standard
SETPT (Setpt)	Setpoint Temperature
SHLD (Shld)	Shield
SPDT	Single Pole Double Throw, a type of switch
SSD	Client to Client programming
SSOV	Safety Shut Off Valve
SV	Sequencing Valve (Used with Water Heater Management (WHM) system)
TEMP (Temp)	Temperature
Terminating Resistor	A resistor placed at each end of a daisy-chain or multi-drop network in order to prevent reflections that may cause invalid data in the communication
Tip-N-Tell	A device that indicates if a package was tipped during shipping
UL	A business that tests and validates products
VAC	Volts, Alternating Current
VDC	Volts, Direct Current
VFD	Vacuum Fluorescent Display, also Variable Frequency Drive
W	Watt
WHM	Water Heater Management
W.C.	Water Column, a unit of pressure (1 inch W.C. = 249 Pa)
µA	Micro amp (1 million <sup>th</sup> of an ampere)

## CHAPTER 1. SAFETY PRECAUTIONS

### 1.1 WARNINGS & CAUTIONS

Installers and operating personnel **MUST**, at all times, observe all safety regulations. The following warnings and cautions are general and must be given the same attention as specific precautions included in these instructions. In addition to all the requirements included in this AERCO Instruction Manual, the installation of units **MUST** conform with local building codes, or, in the absence of local codes, ANSI Z223.1 (National Fuel Gas Code Publication No. NFPA-54) for gas-fired heaters and ANSI/NFPASB for LP gas-fired heaters. Authorities having jurisdiction should be consulted before installations are made.

#### IMPORTANT!

This Instruction Manual is an integral part of the product and must be maintained in legible condition. It must be given to the user by the installer and kept in a safe place for future reference.

#### IMPORTANT!

Read the following restrictions prior to installing the water heater:

1. The water heater can only be used for applications where the chlorine concentrations Do Not Exceed 4 mg/L, which is the Environmental Protection Agency limit for chlorine concentrations in drinking water.
2. Do Not use this heater for a pool heating application.

#### WARNING!

**DO NOT USE MATCHES, CANDLES, FLAMES, OR OTHER SOURCES OF IGNITION TO CHECK FOR GAS LEAKS.**

#### WARNING!

**FLUIDS UNDER PRESSURE MAY CAUSE INJURY TO PERSONNEL OR DAMAGE TO EQUIPMENT WHEN RELEASED. BE SURE TO SHUT OFF ALL INCOMING AND OUTGOING WATER SHUTOFF VALVES AND CAREFULLY DECREASE ALL TRAPPED PRESSURES TO ZERO BEFORE PERFORMING MAINTENANCE.**

#### WARNING!

**ELECTRICAL CURRENT OF 220, 110 AND 24 VOLTS AC MAY BE USED IN THIS EQUIPMENT. THEREFORE THE COVER OF THE UNIT'S POWER BOX (LOCATED BEHIND THE FRONT PANEL DOOR) MUST BE INSTALLED AT ALL TIMES, EXCEPT DURING MAINTENANCE AND SERVICING.**



**WARNING!**

A SWITCH MUST BE INSTALLED ON THE ELECTRICAL SUPPLY LINE OF THE UNIT, IN AN EASILY ACCESSIBLE POSITION TO QUICKLY AND SAFELY DISCONNECT ELECTRICAL SERVICE. DO NOT AFFIX SWITCH TO UNIT SHEET METAL ENCLOSURES.

**CAUTION!**

Many soaps used for gas pipe leak testing are corrosive to metals. The piping must be rinsed thoroughly with clean water after leak checks have been completed.

**CAUTION!**

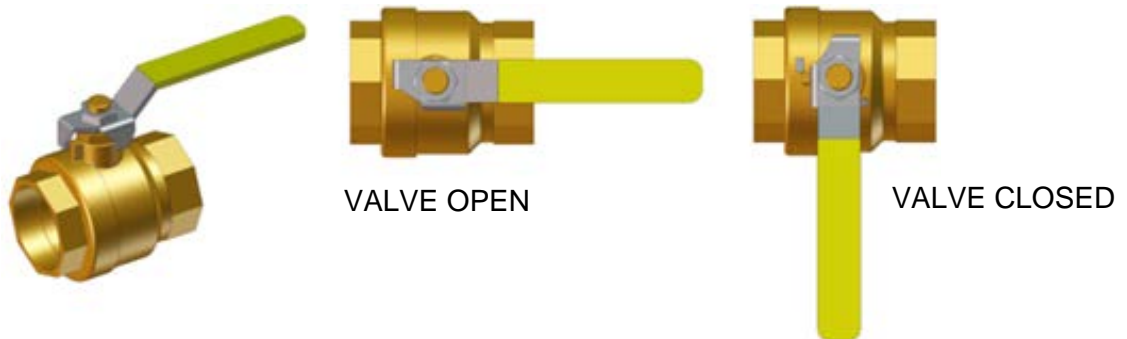
DO NOT use this heater if any part has been under water. Call a qualified service technician to inspect and replace any part that has been under water.

## 1.2 EMERGENCY SHUTDOWN

If overheating occurs or the gas supply fails to shut off, close the manual gas shutoff valve (Figure 1-1) located external to the unit.

**IMPORTANT!**

The Installer must identify and indicate the location of the emergency shutdown manual gas valve to operating personnel.



**Figure 1-1. Manual Gas Shutoff Valve**

## 1.3 PROLONGED SHUTDOWN

After prolonged shutdown, it is recommended that the initial startup procedures in Chapter 4 and the safety device test procedures in Chapter 5 of this manual be performed to verify all system-operating parameters. If there is an emergency, turn off the electrical power supply to the AERCO heater and close the manual gas valve located upstream of the unit. The installer must identify the emergency shut-off device.

## CHAPTER 2. INSTALLATION

### 2.1 INTRODUCTION

This Chapter provides the descriptions and procedures necessary to unpack, inspect and install AERCO Innovation Water Heaters.

### 2.2 RECEIVING THE UNIT

Each Innovation Water Heating System is shipped as a single crated unit. The shipping weight is shown in the Forward to this manual, in Table F1. The unit must be moved with the proper rigging equipment for safety and to avoid equipment damage. The unit should be completely inspected for evidence of shipping damage and shipment completeness at the time of receipt from the carrier and before the bill of lading is signed.

**NOTE:**

AERCO is not responsible for lost or damaged freight. Each unit has a Tip-N-Tell indicator on the outside of the shipping container, which indicates if the unit has been turned on its side during shipment. If the Tip-N-Tell indicator is tripped, do not sign for the shipment. Note the information on the carrier's paperwork and request a freight claim and inspection by a claims adjuster before proceeding. Any other visual damage to the packaging materials should also be made clear to the delivering carrier.

### 2.3 UNPACKING

Carefully unpack the unit taking care not to damage the unit's enclosure when cutting away packaging materials

After unpacking, closely inspect the unit to make sure there is no evidence of damage not indicated by the Tip-N-Tell indicator. Notify the freight carrier immediately if any damage is detected.

The following accessories come standard with each unit and are either packed separately within the unit's shipping container or are factory installed on the unit:

- ASME Pressure and Temperature Relief Valve
- Condensate Drain Trap

If the Innovation Water Heater is equipped for use with the AERCO Water Heater Management (WHM) system, an actuator-controlled ball valve will also be included with the unit.

When optional accessories are ordered, they may be packed within the unit's shipping container, factory installed on the unit, or packed and shipped in a separate container. Any standard or optional accessories shipped loose should be identified and stored in a safe place until ready for installation or use.

## 2.4 SITE PREPARATION

Ensure that the site selected for installation of the Innovation Water Heater includes:

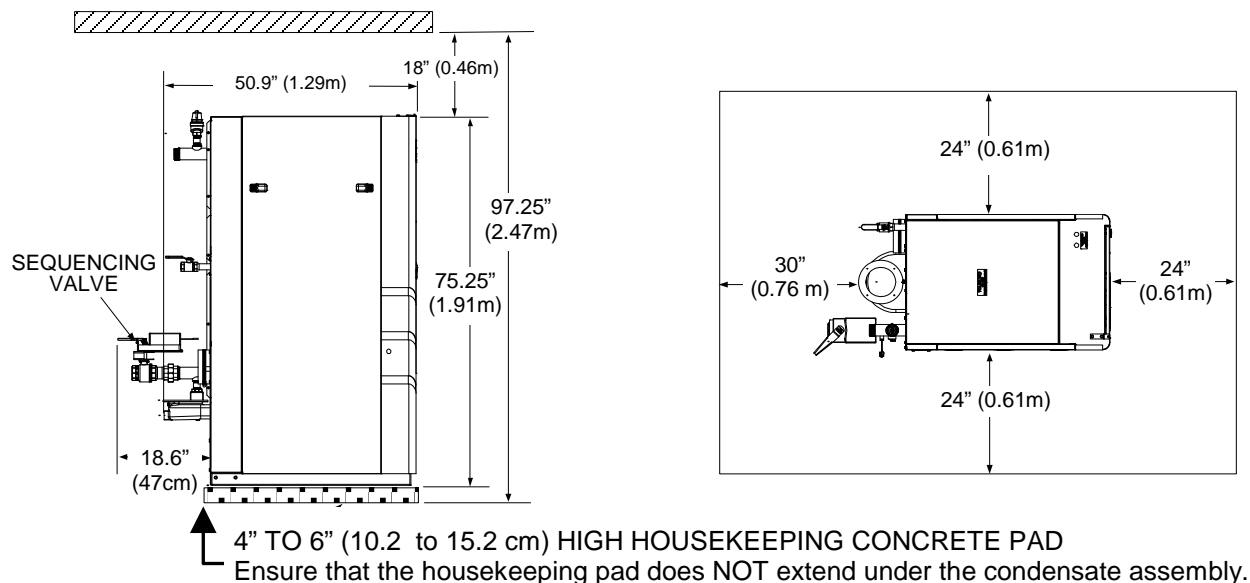
- Access to AC Input Power at 220 VAC, Single-Phase, 60 Hz @ 20 Amps.
- Access to a Natural Gas line with a **minimum** pressure of **4 inches W.C. (1.0 kPa)** or to a Propane gas line with a **minimum** pressure of **7 inches W.C. (1.7 kPa)** with the unit **operating at maximum capacity.**

### 2.4.1 Installation Clearances

All Innovation models are packaged in enclosures having identical exterior dimensions. The unit must be installed with the prescribed clearances for service as shown in Figure 2-1 (shown with optional Sequencing Valve). The minimum clearance dimensions, required by AERCO, are listed below. However, if Local Building Codes require additional clearances, these codes shall supersede AERCO's requirements. Minimum acceptable clearances required are as follows:

- Sides: 24 inches (0.61 m)
- Front: 24 inches (0.61 m)
- Rear: 30 inches (0.76 m)
- Top: 18 inches (0.46 m)

All gas piping, water piping and electrical conduit or cable must be arranged so that they do not interfere with the removal of any panels, or inhibit service or maintenance of the unit.



**Figure 2-1. Innovation Water Heater Clearances**

#### WARNING!

KEEP THE UNIT AREA CLEAR AND FREE FROM ALL COMBUSTIBLE MATERIALS AND FLAMMABLE VAPORS OR LIQUIDS.

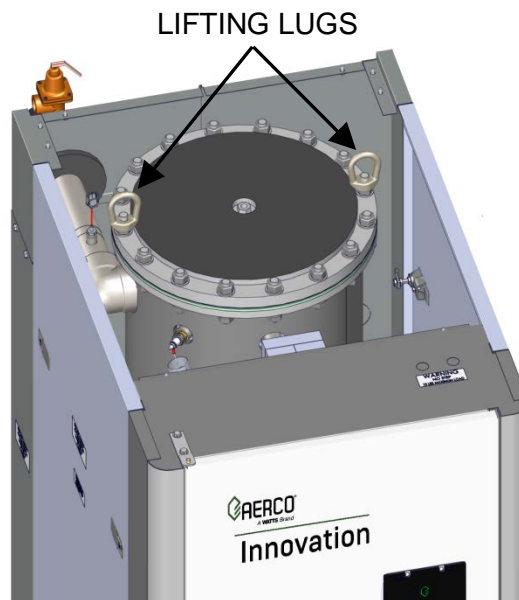
#### CAUTION!

While packaged in the shipping container, the unit must be moved by pallet jack or forklift from the FRONT ONLY.

### 2.4.2 Setting the Unit

The unit must be installed on a **4 to 6 inch (10.2 to 15.2 cm)** housekeeping pad to avoid base corrosion. Two lifting lugs are provided with the unit and are wire-tied to the top of the heat exchanger. The top sheet metal cover of the unit must first be removed and the lifting lugs must be installed as shown in Figure 2-2. **USE THESE TWO LUGS TO LIFT AND MOVE THE UNIT.** Remove the top panel from the unit to provide access to the lifting lugs. Remove the four (4) lag screws securing the unit to the shipping skid. Lift the unit off the shipping skid and position it on the 4 to 6 inch (10.2 to 15.2 cm) housekeeping concrete pad (required) in the desired location.

In multiple unit installations, it is important to plan the position of each unit in advance. Sufficient space for piping connections and future service/maintenance requirements must also be taken into consideration. All piping must include ample provisions for expansion.



**Figure 2-2. Partial Top View Showing Installed Lifting Lugs**

## 2.5 WATER INLET AND OUTLET PIPING

The locations of the 2" (5.08 cm) NPT cold water inlet and hot water outlet piping connections are shown in Figure 2-3a. Flow rates through the unit are limited to 50 gallons (189 Liters) per minute continuous.

Shut-off valves and union connections must be installed in the inlet and outlet lines for maintenance. The use of dielectric unions is recommended.

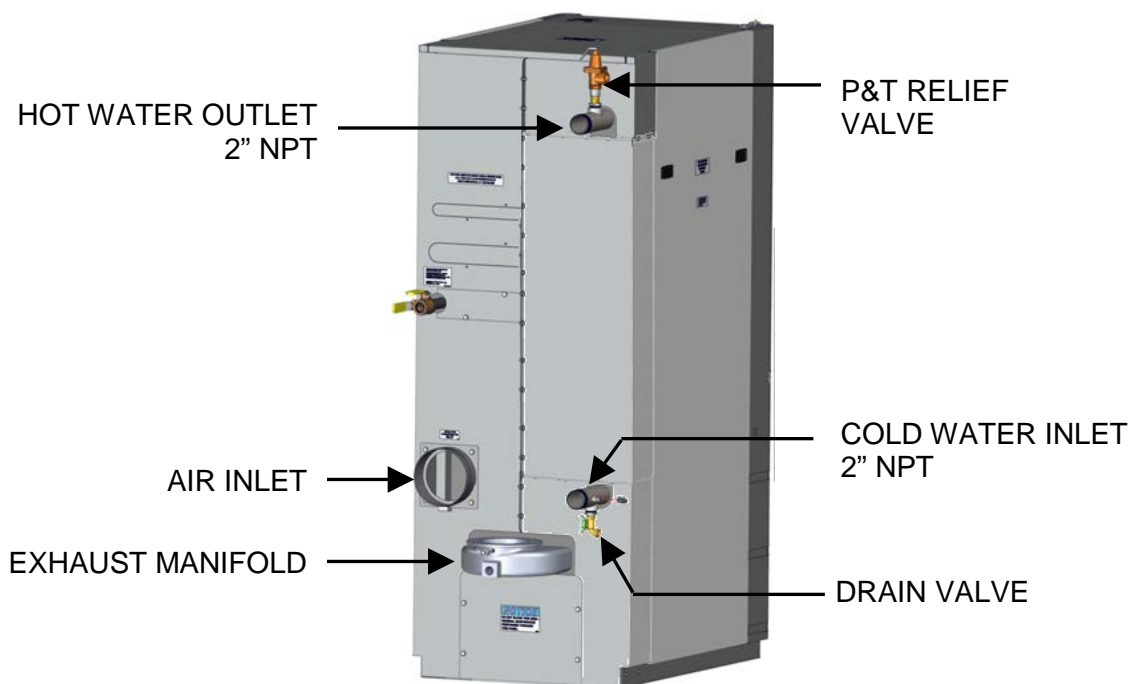
When connecting the hot water outlet and cold water inlet to building piping, first make sure the threads are thoroughly clean. AERCO recommends using Teflon tape followed by RectorSeal® T+2 when plumbing the inlet and outlet water connections.

### IMPORTANT!

If the Innovation Water Heater is equipped for use with the C-More Water Heater Management (WHM) system, then an actuator-controlled ball valve will be included with the shipment. Refer to Section 2.5.1 for installation instructions prior to connecting inlet piping.

### NOTE:

All piping must be arranged so that it does not interfere with the removal of any covers, inhibit service or maintenance, or prevent access between the unit and walls, or another unit.



**Figure 2-3a. Water Inlet & Outlet Locations**

### 2.5.1 WHM Actuator-Controlled Ball Valve Installation

If the Innovation Water Heater was ordered for use with the Water Heater Management (WHM) system and the actuator-controlled ball valve is not already installed on the unit, as shown in Figure 2-3b, it will be packed separately within the shipping container.

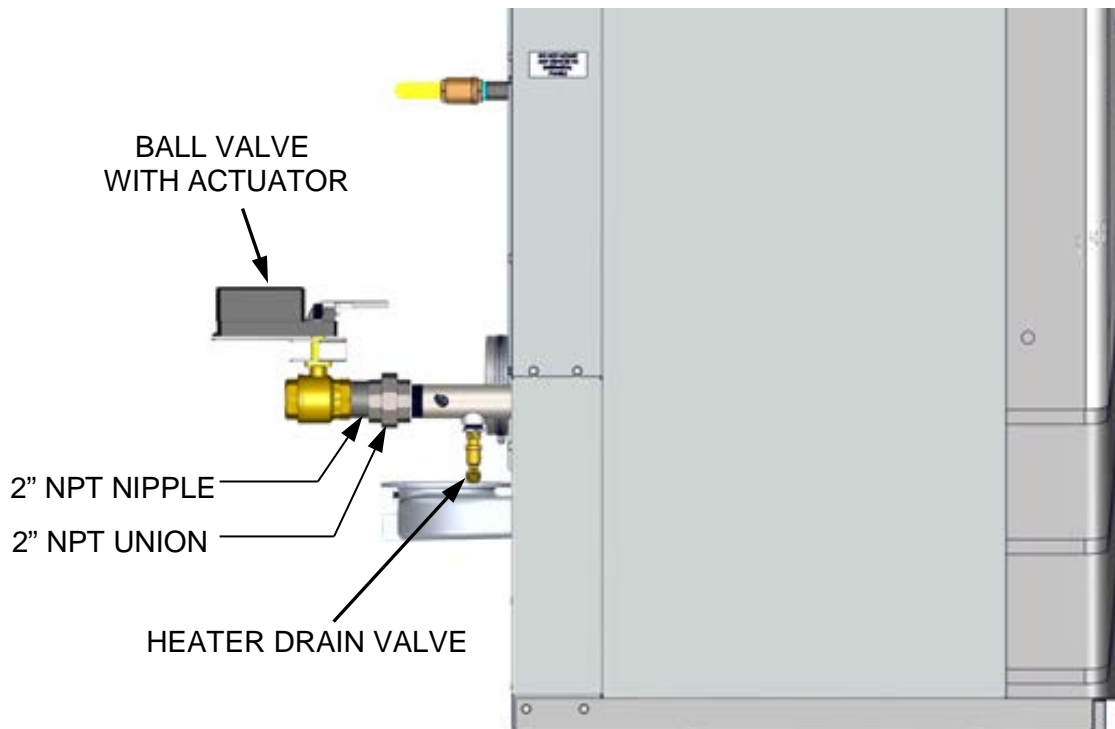
**NOTE:**

AERCO requires use of WHM sequencing valves in a multi-unit configuration. See Section 4.2.6: *Recommendations for WHM Operation* for more information.

If installation is required, proceed as follows:

#### WHM BALL VALVE INSTALLATION Instructions

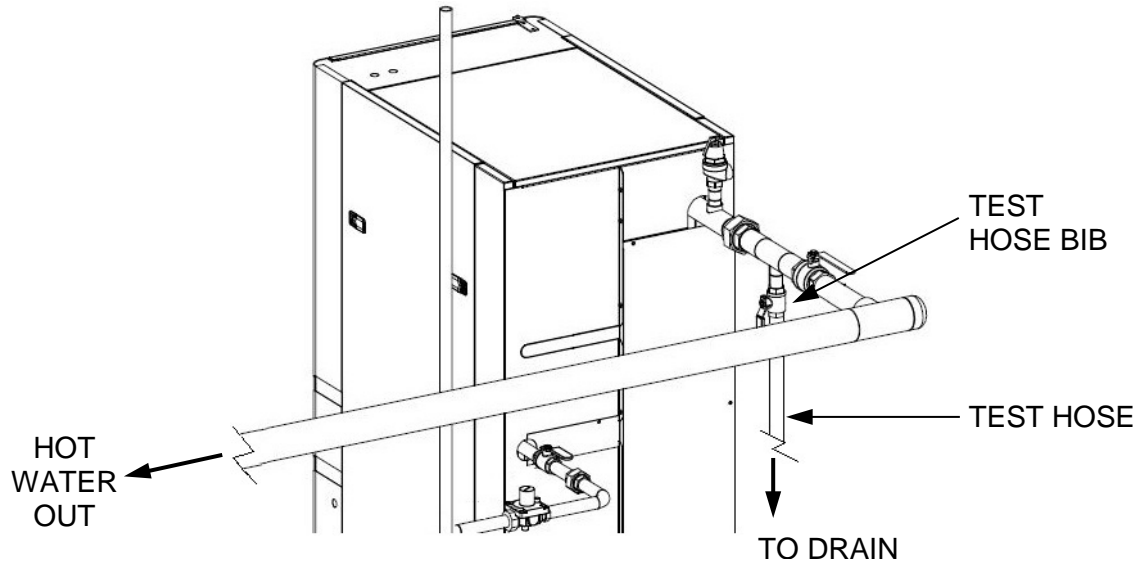
1. Remove the ball valve from its stowed location within the shipping container.
2. Attached the valve to the cold water inlet of the unit using the pipe union and nipple provided.
3. Ensure that the valve is positioned with the actuator enclosure position as shown in Figure 2-3b.
4. AERCO recommends that another pipe nipple and union be attached to the valve inlet prior to connecting the cold water supply piping.
5. Tighten all pipe connections after the valve is properly positioned.
6. Connect the 4-pin Molex connector on the valve to the mating connector on the Innovation harness at the rear of the unit.
7. This completes the actuator-controlled ball valve installation.



**Figure 2-3b. Innovation Water Heater Equipped With Sequencing Valve**

## 2.6 TEST HOSE BIB CONNECTION

A Test Hose Bib connection, upstream of the shut off valve on the hot water outlet, is **required** for startup and testing (Figure 2-4). The test hose diameter should be a minimum of 3/4" (1.9 cm). The Test Hose Bib **cannot be omitted**.



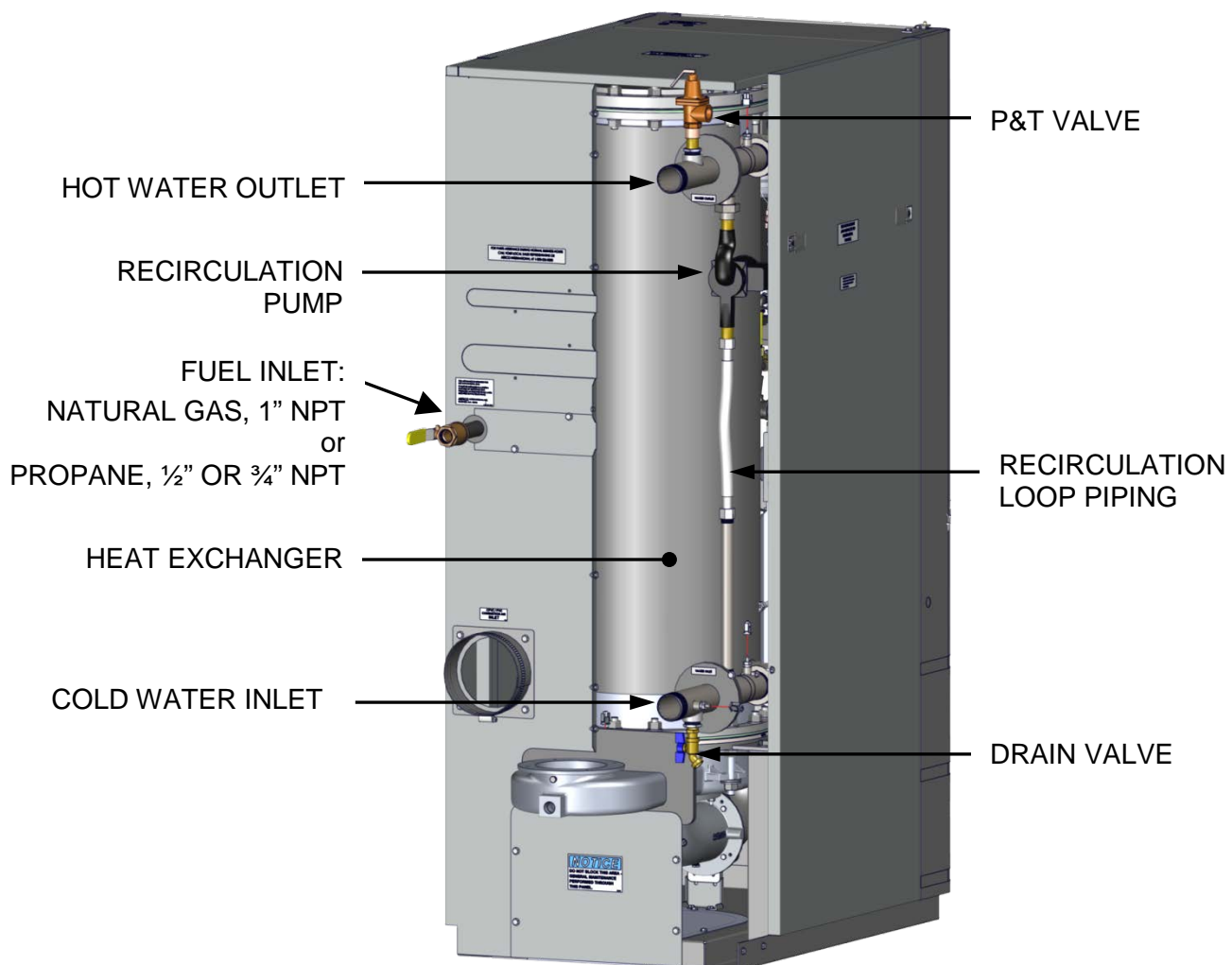
**Figure 2-4. Test Hose Bib Location**



## 2.7 INTERNAL RECIRCULATION LOOP

The internal Recirculation Loop Assembly is located inside the unit enclosure at the rear of the unit. In order to access this assembly, the right-rear panel must be removed, as shown in Figure 2-5.

This assembly contains a recirculation pump that connects the upper hot water outlet to the lower cold water inlet to the unit's heat exchanger. The purpose of this loop is to provide feed-forward (FFWD) temperature control by mixing a portion of the hot water outlet with the cold water inlet to the unit. Temperature sensors located in the hot water outlet and cold water inlet provide temperature data to the C-More Controller. The Controller utilizes this data to modulate the fire rate (Air/Fuel Valve position) to precisely maintain the hot water outlet temperature at the selected setpoint temperature.



REAR VIEW – -REAR PANEL & EXHAUST VENT REMOVED

**Figure 2-5. Recirculation Loop**

### 2.8 PRESSURE & TEMPERATURE RELIEF VALVE INSTALLATION

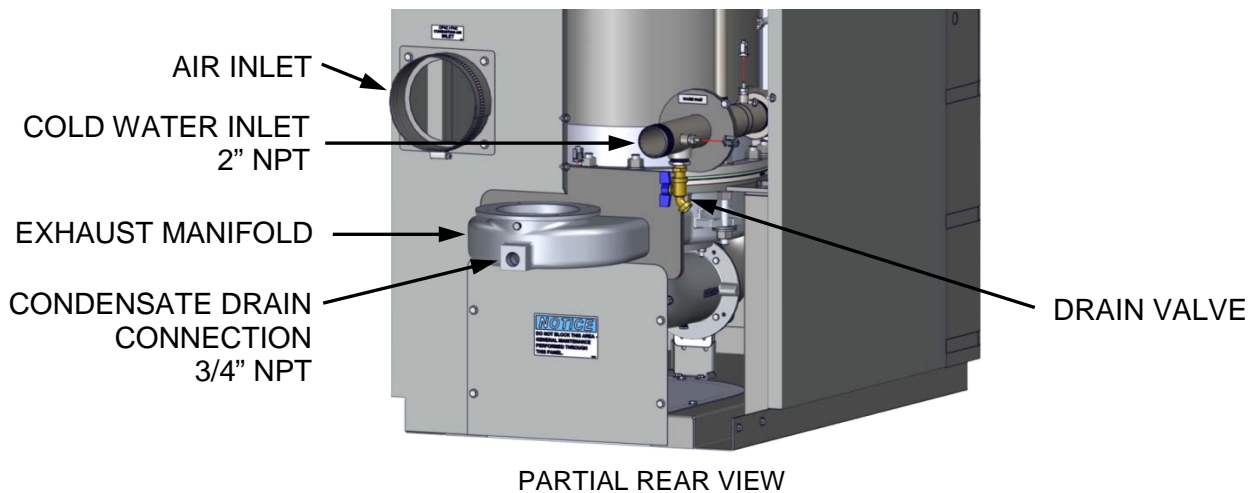
An ASME rated Pressure & Temperature (P&T) Relief Valve must be installed on each Innovation water heater, on the hot water outlet at the top of the Recirculation Loop Assembly as shown in Figure 2-5, above. The valve setpoint is 150 psig (1,034 kPa) at 210°F (98.9° C).

A suitable pipe joint compound should be used on the threaded connections. Any excess should be wiped off to avoid getting any into the valve body. The relief valve should be piped to within 6 inches (15.2 cm) of the floor to prevent injury in the event of a discharge. The relief outlet piping must be equal to the outlet size of the relief valve without reduction. No valves, restrictions, or other blockages are allowed in the discharge line. In multiple unit installations the discharge lines must not be manifolded together. Each must be individually run to a suitable discharge location.

### 2.9 CONDENSATE DRAIN & PIPING

The Innovation Water Heater is designed to condense water vapor from the flue products. Therefore, the installation must have provisions for suitable condensate drainage or collection.

The condensate drain port is located on the exhaust manifold at the rear of the unit (Figure 2-6). This drain port must be connected to the Condensate Trap (P/N **24441**), which is packed within the unit's shipping container. The Condensate Trap inlet and outlet connections contain tapped 3/4" (1.91 cm) NPT ports.



**Figure 2-6. Condensate Drain Connection Location**

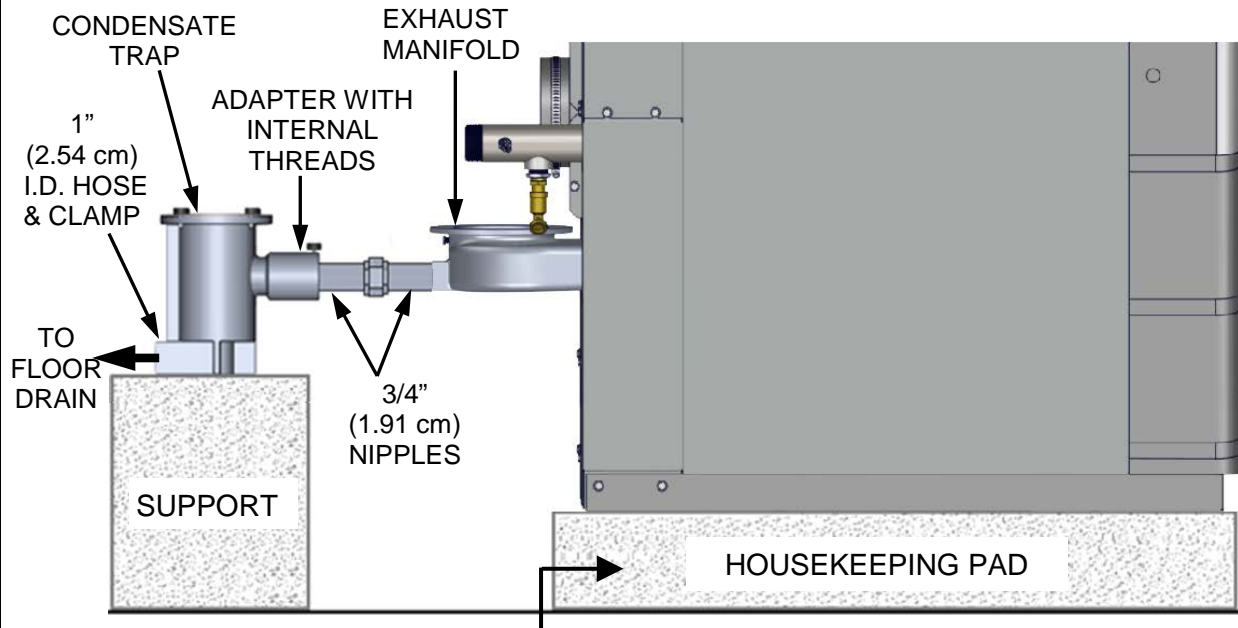
A sample Condensate Trap installation is shown in Figure 2-7. However, the actual installation details for the trap will vary depending on the available clearances, housekeeping pad height/ dimensions and other prevailing conditions at the site. The following general guidelines must be observed to ensure proper condensate drainage:

- The condensate trap inlet must be level with, or lower than the exhaust manifold drain port.
- The base of the condensate trap must be supported to ensure that it is level (horizontal).
- The trap must be removable for routine maintenance (see Section 6.9 for instructions). AERCO recommends that a union be utilized between the exhaust manifold condensate drain port and the trap inlet port.

While observing the guidelines above, install the condensate trap as follows:

### CONDENSATE TRAP INSTALLATION Instructions

1. Connect the condensate trap inlet to the exhaust manifold drain connection using piping components (nipples, reducers, elbows, etc.) appropriate for the site.
2. At the condensate trap outlet, install a 3/4" NPT nipple.
3. Connect a length of 1" (2.54 cm) I.D. polypropylene hose to the trap outlet.
4. Route the hose from the trap outlet to a nearby floor drain and secure it with a hose clamp.



Housekeeping pad should not extend under the condensate assembly

**Figure 2-7. Sample Condensate Trap Installation – Left Side View**

If a floor drain is not available, a condensate pump can be used to remove the condensate to a drain. **The maximum condensate flow rate is 10 Gallons (37.85 L) per hour.** The condensate drain trap, associated fittings and drain line must be removable for routine maintenance.

#### CAUTION!

Use PVC, stainless steel, aluminum or polypropylene for condensate drain piping. **DO NOT USE carbon or copper components.**

#### NOTE:

As a general guideline, AERCO recommends use of its Condensate Neutralizer Kit to raise the pH level of the condensate prior to drainage. At a minimum, the installation must be designed in accordance with local codes that specify acceptable pH limits. For more information, see Technical Instruction Document TID-0029, Condensate Neutralization Kit and TID-0074 Condensate Neutralization Tank.

### 2.10 GAS SUPPLY PIPING

The AERCO Innovation Gas Components and Supply Design Guide, GF-5030 must be consulted prior to designing or installing any gas supply piping.

#### WARNING!

NEVER USE MATCHES, CANDLES, FLAMES OR OTHER SOURCES OF IGNITION TO CHECK FOR GAS LEAKS.

#### CAUTION

Many soaps used for gas pipe leak testing are corrosive to metals. Therefore, piping must be rinsed thoroughly with clean water after leak checks have been completed.

#### NOTE:

All gas piping must be arranged so that it does not interfere with removal of any covers, inhibit service/maintenance, or restrict access between the unit and walls, or another unit.

Innovation units contain one of the following gas inlet connection on the rear of the unit, as shown in Figure 2-5, above.

Inlet Connection	Innovation Model
1 Inch (2.54 cm) Natural Gas	All INN models
0.5 Inch (1.27 cm) Propane	INN 600P and INN 800P
0.75 Inch (1.91 cm) Propane	INN 1060P and INN 1400P

Prior to installation, all pipes should be de-burred and internally cleared of any scale, metal chips or other foreign particles. Do Not install any flexible connectors or unapproved gas fittings. Piping must be supported from the floor, ceiling or walls only and must not be supported by the unit.

A suitable piping compound, approved for use with natural gas, should be used. Any excess must be wiped off to prevent clogging of components.

To avoid unit damage when pressure testing the gas piping, isolate the unit from the gas supply piping. **For both Natural Gas and Propane, the gas pressure applied to the unit should never exceed 14" W.C. (3.49 kPa).** Leak test all external piping thoroughly using a soap and water solution or suitable equivalent. The gas piping used must meet all applicable codes.

### 2.10.1 Gas Supply Specifications.

The gas supply input specifications to the unit for Natural Gas and Propane are as follows:

- The **maximum** static pressure to the unit must not exceed **14" W.C. (3.49 kPa)**.
- The **minimum** pressure for Natural Gas is **4.0" W.C. (1.0 kPa)**.
- The **minimum** pressure for Propane is **6.0" W.C. (1.5 kPa)**.
- The gas supply pressure to the unit must be of sufficient capacity to provide the following while maintaining a gas pressure of 7" W.C. (1.74 kPa) **with the unit operating at maximum capacity**:
  - INN 600: 600 BTU (0.176 kW)
  - INN 800: 800 BTU (0.234 kW)
  - INN 1060: 1060 BTU (0.311 kW)
  - INN 1400: 1400 BTU (0.410 kW)

### 2.10.2 Manual Gas Shutoff Valve

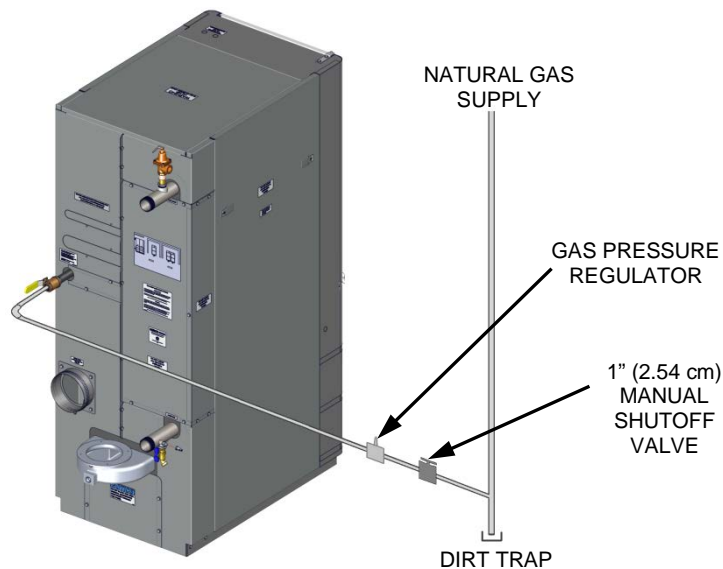
A manual shut-off valve is factory-installed in the gas supply line at the unit, as shown in Figure 2-3a. Additionally, if a gas regulator is installed upstream of the unit, refer to Figure 2-8 to determine the location of the manual shut-off valve installation in relation to the regulator. The maximum allowable gas pressure to the Heater is 14" W.C. (3.49 kPa).

### 2.10.3 External Gas Supply Regulator

An external gas pressure regulator is required on the gas inlet piping under most conditions. Regulators must conform to the following specifications:

- The external natural gas regulator must be capable of regulating 200,000 BTU/Hr. to 3,180,000 BTU/Hr. (58.61 kW to 932.0 kW) of natural gas while maintaining a gas pressure of 8.0" W.C. (1.99 kPa) minimum to the unit.
- A lock-up style regulator ***is required*** when gas supply pressure **exceeds 14" W.C. (3.49 kPa)**.

An external gas supply regulator is *recommended* for all installations that **exceed 7" W.C. (1.74 kPa)** gas pressure, positioned as shown in Figure 2-8. No regulator is required for gas pressures below 7" W.C. (1.74 kPa) of pressure. Consult the local gas utility for detailed requirements concerning venting of the supply gas regulator.



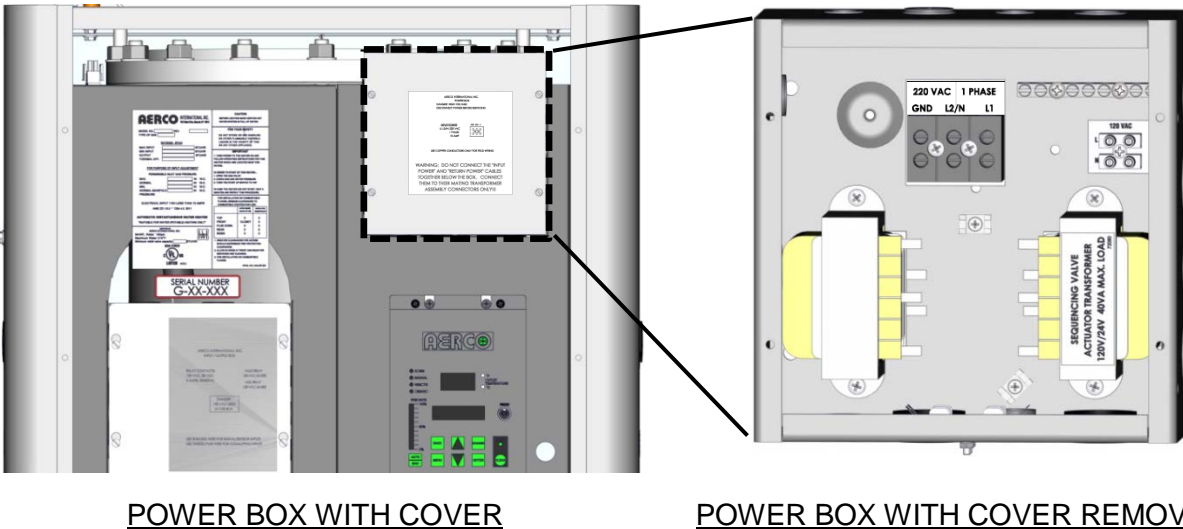
**Figure 2-8. Manual Gas Shut-Off Valve Location**

**NOTE:**

It is the responsibility of the customer to source and purchase the appropriate gas regulator as described above. However, AERCO offers for sale an appropriate regulator, which may be ordered at the time of unit purchase or separately. Contact AERCO for more information.

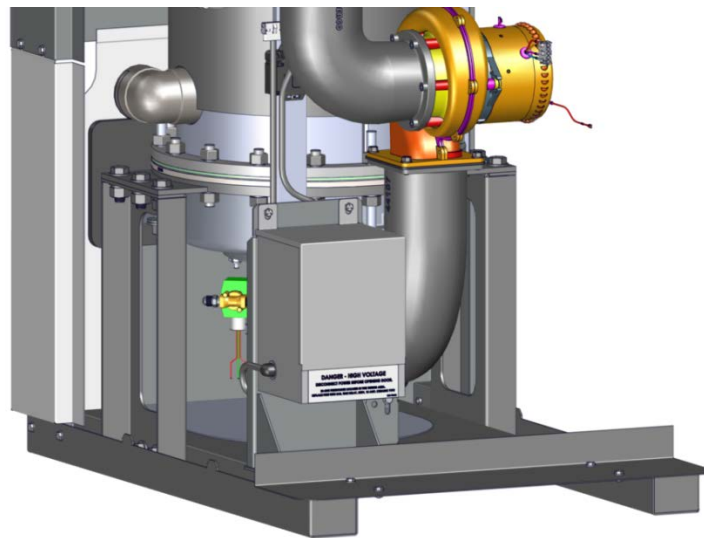
### 2.11 AC ELECTRICAL POWER WIRING

The AERCO Innovation Electrical Power Wiring Guide, GF-5060, must be consulted prior to connecting any AC power wiring to the unit. External AC power connections are made to the unit inside the Power Box on the front of the unit. Remove the front door of the unit to access the Power Box mounted directly above the C-More Controller. Loosen the four Power Box cover screws and remove the cover to access the AC terminal connections inside the Power Box (Figure 2-9).



**Figure 2-9. Power Box Location – Partial Front View, Front Panel Removed**

Innovation units operate on 120 VAC power internally. All units sent to Korea include a pre-wired 220 VAC to 120 VAC transformer installed inside the unit, as shown in Figure 2-10.



**Figure 2-10. 220 V Transformer – Front and Side Panels Removed**



### 2.11.1 Electrical Power Requirements

AERCO Innovation Heater built for the Korea market require the following input voltage:

- 220 VAC, single-phase, 50/60 Hz @ 20A

**NOTE:**

All electrical conduit and hardware must be installed so that it does not interfere with the removal of any unit covers, inhibit service/maintenance, or prevent access between the unit and walls or another unit.

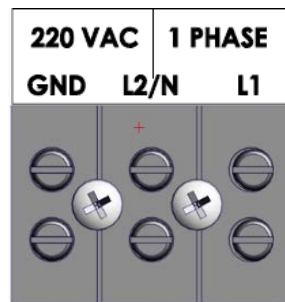
The Power Box contains the terminal block shown in Figure 2-11. A wiring diagram showing the required AC power connections is mounted on the front cover of the Power Box.

Each unit must be connected to a dedicated electrical circuit. **NO OTHER DEVICES SHOULD BE ON THE SAME ELECTRICAL CIRCUIT AS THE HEATER.**

A double-pole switch must be installed on the electrical supply line in an easily accessible location to quickly and safely disconnect electrical service. **DO NOT** attach the switch to sheet metal enclosures of the unit.

After placing the unit in service, the ignition safety shutoff device must be tested. If an external electrical power source is used, the installed boiler must be electrically bonded to ground in accordance with the requirements of the authority having jurisdiction.

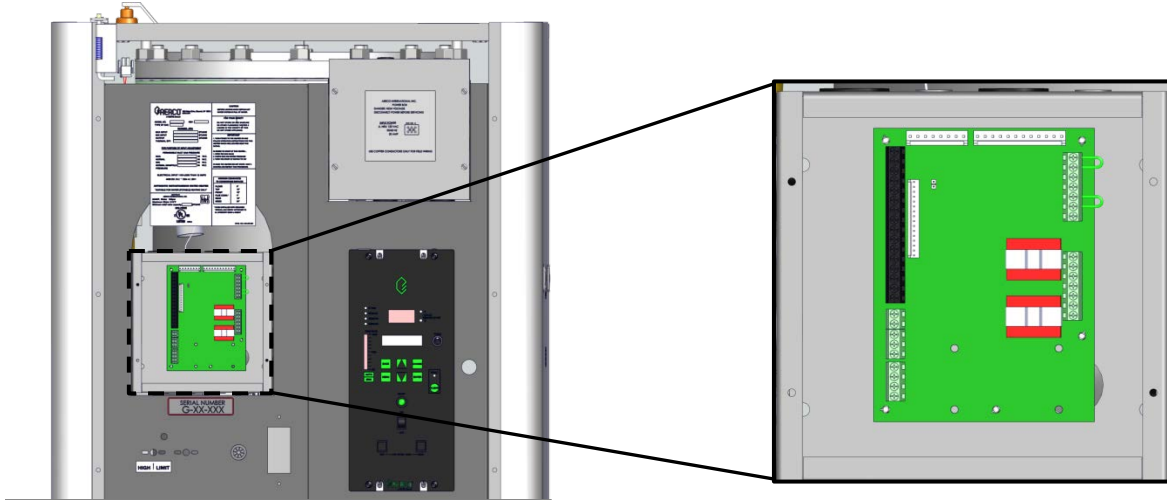
For electrical power wiring diagrams, see the AERCO Innovation Electrical Power Wiring Guide, (GF-5060).



**Figure 2-11. AC Terminal Block Configurations for 220 VAC Input**

### 2.12 FIELD CONTROL WIRING

Each unit is fully wired from the factory with an internal operating control system. No field control wiring is required for normal operation. However, the C-More control system used with all Innovation water heaters does allow for some control and monitoring features. Wiring connections for these features are made in the Input/Output (I/O) Box. The I/O Box is located on the upper-left portion of the unit front panel (Figure 2-12) behind the removable front panel door. To access the I/O Box terminal strips shown in Figure 2-12, loosen the four cover screws and remove the cover. All field wiring is installed from the rear of the panel by routing the wires through one of the four bushings provided.



**Figure 2-12. Input/Output (I/O) Box Location – Partial Front View**

Refer to the wiring diagram provided on the cover of the I/O Box (Figure 2-13) when making all wiring connections.

Since identical I/O Boxes are used with both AERCO gas-fired boilers and water heaters, some of the input and output connections apply only to boilers while others are common to both boilers and heaters. These I/O Box connections are noted in the sections below.

#### **NOTE**

Use Figure 2-13 to determine the functions of the I/O PCB connections. Do not use the silkscreened labels on the PCB itself, as these may not match.

#### **CAUTION!**

DO NOT make any connections to the I/O Box terminals labeled “NOT USED”. Attempting to do so may cause equipment damage.

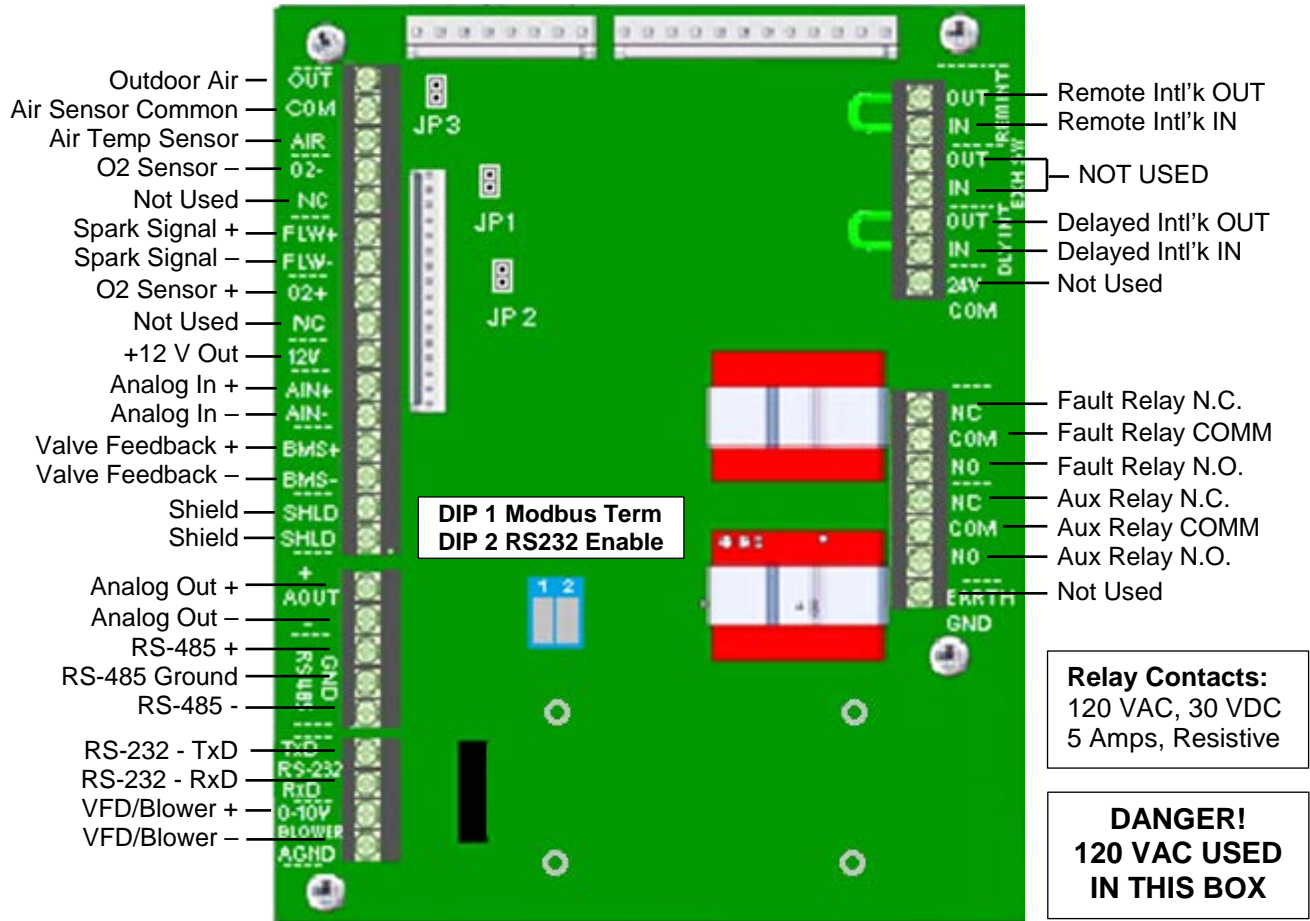


Figure 2-13. I/O Box Terminal Strips

### 2.12.1 OUTDOOR AIR IN Terminal

The OUTDOOR AIR IN and AIR SENSOR COMMON terminals are not applicable to this unit.

### 2.12.2 COMBUSTION AIR Terminals

The COMBUSTION AIR and AIR SENSOR COMMON terminals are not applicable to this unit.

### 2.12.3 O2 SENSOR Terminals

The O2 SENSOR (-) and O2 SENSOR (+) terminals are not currently used in this unit.

### 2.12.4 SPARK SIGNAL Terminals

The SPARK SIGNAL terminals (+ & -) connect to the spark monitor (P/N 61034, also called "AC Current transducer"), which monitors the current going to the ignition transformer (P/N 65085, see Section 6.14). If the current is insufficient (too high or low) during the ignition sequence, the controller will abort the ignition cycle. The controller will attempt up to three ignition cycles. If the current is insufficient by the third try, the controller will shut down and display a fault message.

### 2.12.5 ANALOG IN Terminals

The ANALOG IN terminals (+ & -) are used when an external signal is used to change the setpoint (Remote Setpoint mode) of the heater.

Either a 4 to 20 mA / 1 to 5 VDC or a 0 to 20 mA / 0 to 5 VDC signal may be used to vary the setpoint or air/fuel valve position. The factory default setting is for 4 to 20 mA / 1 to 5 VDC, however this may be changed to 0 to 20 mA / 0 to 5 VDC using the Configuration Menu described in Chapter 3.

If voltage rather than current is selected as the drive signal, a DIP switch must be set on the PMC Board located inside the C-More Controller. Refer to Appendix D in C-More Manual GF-112 for information on setting DIP switches.

All supplied signals must be floating (ungrounded) signals. Connections between the source and the Heater's I/O Box must be made using twisted shielded pair of 18–22 AWG wire such as Belden 9841. Polarity must be maintained and the shield must be connected only at the source end and must be left floating (not connected) at the unit's I/O Box.

Whether using voltage or current for the drive signal, they are linearly mapped to a 40°F (4.44 °C) to 240°F (115.6 °C) setpoint or a 0% to 100% air/fuel valve position. No scaling for these signals is provided.

### 2.12.6 VALVE FEEDBACK Terminals

The Valve Feedback terminals are used when the Sequencing Isolation Valve Feedback option is selected. The Valve Feedback signal is connected to the "Valve Fdbk" terminals and is used to confirm that the valve has properly opened or closed. If the Valve Feedback signal does not match the Valve-Open or Valve-Close command for the time defined in the "Valve Fdbk timer" entry, the controller will proceed as follows:

- (a) If the valve fails with the Valve Stuck Open fault, the **VALVE STUCK OPEN** message will be displayed and the unit will remain active.
- (b) If the valve fails with the Valve Stuck Closed fault, the **VALVE STUCK CLOSED** message will be displayed and the unit will shut down.

#### NOTE:

If the Valve Feedback option is used, Shorting Jumper #JP2 on the I/O Board will be inserted at the factory.

### 2.12.7 SHIELD Terminals

The two SHIELD terminals are used to terminate any shields used on sensor wires connected to the unit. Only shields must be connected to these terminals.

### 2.12.8 ANALOG OUT Terminals

The two ANALOG OUT terminals (+ & -) output from 0 to 20 mA and may be used to monitor Setpoint, Outlet Temperature, Valve Position 4-20 mA, Valve Position 0-10v or be set to OFF. Default setting in the C-More controller is Valve Position 0-10 v and settings behave as follows:

1. 0-10VDC **must** be selected for the voltage output used by the controller to modulate the combustion blower via the I/O Box terminals labeled **VFD/BLOWER** (Section 2.12.11).
2. If "On Board" Water Heater Management is enabled, the Analog Output terminals are used to drive the isolation valve, open and closed.

**NOTE:**

When driving an isolation valve, shorting jumper #JP2 *MUST* be installed on the I/O Board.

### 2.12.9 RS485 Comm Terminals

The RS485 communication terminals (+, GND, & -) are used when the Innovation Water Heaters are being controlled by an Energy Management System (EMS) or the C-More Water Heater Management (WHM) system using Modbus (RS485) communication. The WHM software required to control up to 8 AERCO Innovation Water Heaters is included in the C-More Control System used with each Innovation unit.

### 2.12.10 RS232 Comm Terminals

As of Firmware version 4.0 and above, these terminals are used only by factory-trained personnel to monitor OnAER communications via a portable computer.

### 2.12.11 VFD/BLOWER Terminals

These terminals (0-10 & AGND) send an analog signal to control the blower speed. When any of the 4-20 mA options is selected for the Analog Outputs (Section 2.12.8), the output from the VFD/Blower terminals is disabled.

### 2.12.12 Interlock Terminals

The unit offers two interlock circuits for interfacing with Energy Management Systems and auxiliary equipment such as pumps or louvers or other accessories. These interlocks are called the Remote Interlock and Delayed Interlock (REMOTE INTL'K IN and DELAYED INTL'K IN in Figure 2-13). Both interlocks, described below, are factory wired in the closed position.

**NOTE**

Both the Remote Interlock and Delayed Interlock must be in the closed position for the unit to fire.

#### 2.12.12.1 REMOTE INTL'K Terminals

The remote interlock circuit is provided to remotely start (enable) and stop (disable) the unit if desired. The circuit is 24 VAC and comes factory pre-wired closed (jumped).

#### 2.12.12.2 DELAYED INTL'K Terminals

The delayed interlock is typically used in conjunction with the Auxiliary Relay Contacts described in Section 2.12.14. This interlock circuit is located in the purge section of the start string. It can be connected to the proving device (end switch, flow switch etc.) of an auxiliary piece of equipment started by the unit's auxiliary relay. The delayed interlock must be closed for the heater to fire. If the delayed interlock is connected to a proving device that requires time to close (make), a time delay (Aux Start On Dly) that holds the start sequence of the unit long enough for a proving switch to make (close) can be programmed.

Should the proving switch not prove within the programmed time frame, the unit will shut down. The Aux Start On Dly can be programmed from 0 to 120 seconds. This option is located in the Configuration Menu (Chapter 3).

### 2.12.13 FAULT RELAY Terminals

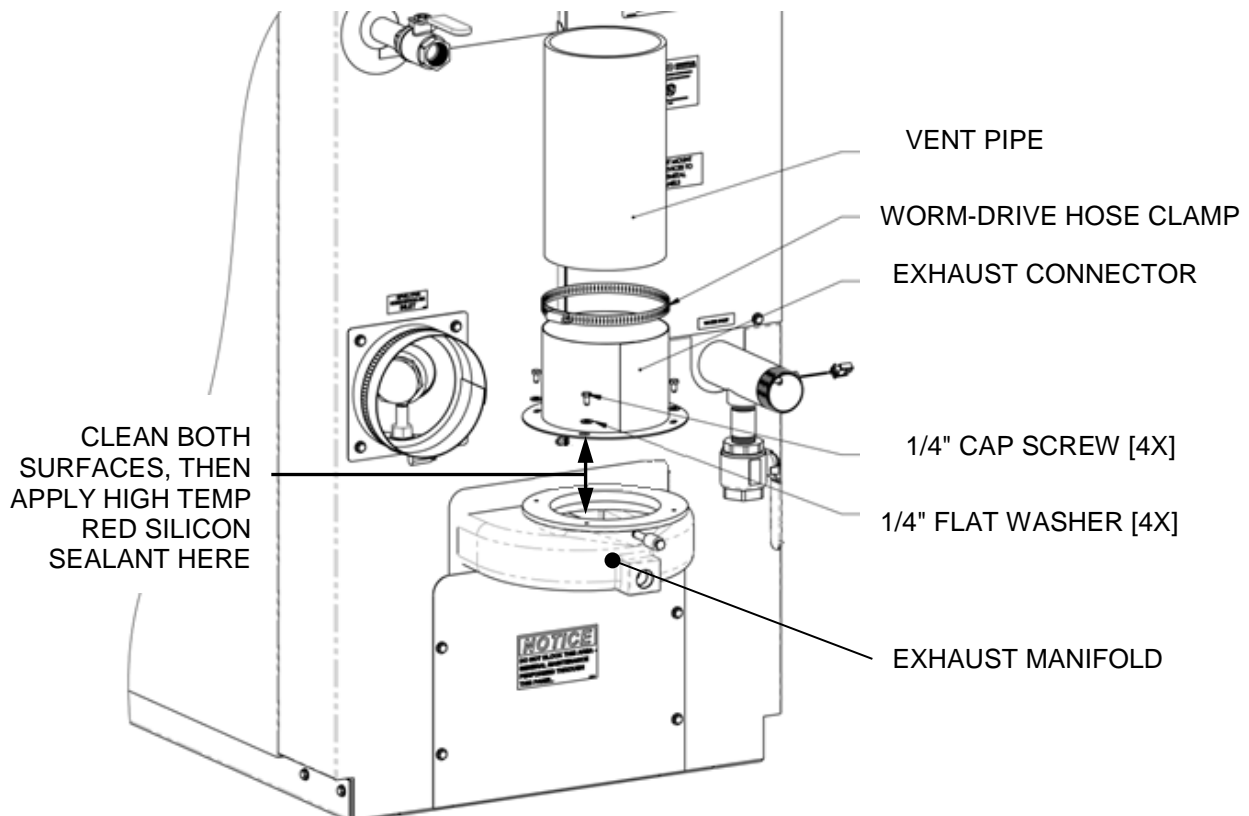
The fault relay is a single pole double throw (SPDT) relay having a normally open and normally closed set of relay contacts that are rated for 5 amps at 120 VAC and 5 amps at 30 VDC. The relay energizes when any fault condition occurs and remains energized until the fault is cleared and the **CLEAR** button is depressed. The Fault Relay connections are shown in Figure 2-13.

### 2.12.14 AUX RELAY Terminals

Each unit is equipped with a single pole double throw (SPDT) auxiliary relay that is energized when there is a demand for heat and de-energized after the demand for heat is satisfied. The relay is provided for the control of auxiliary equipment, such as pumps and louvers, or can be used as a unit status indicator (firing or not firing). Its contacts are rated for 120 VAC @ 5 amps. Refer to Figure 2-13 to locate the AUX RELAY terminals (N.C., COM, & N.O.) for wiring connections.

## 2.13 FLUE GAS VENT INSTALLATION

AERCO Gas Fired Venting and Combustion Air Guide, GF-5050 must be consulted before any flue or combustion air venting is designed or installed. Suitable positive pressure, watertight vent materials **MUST** be used for safety. Because the unit is capable of discharging low temperature exhaust gases, the flue must be pitched back towards the unit a minimum of 1/4" per foot (21 mm per m) to avoid any condensate pooling and to allow for proper drainage. In addition, you must add a bead of high temperature red silicon sealant (such as Permatex Hi-Temp Red RTV or Loctite Superflex Red High Temp RTV) between the exhaust manifold and the mating flange of the exhaust connector, as shown in Figure 2-14.



**Figure 2-14. Exhaust Vent Connection**



While there is a positive flue pressure during operation, the combined pressure drop of vent and combustion air systems **must not exceed 140 equivalent feet (42.7m) or 0.81” W.C. (201 Pa) with 6” (15.24 cm) piping**. Fittings as well as pipe lengths must be calculated as part of the equivalent length. For a natural draft installation the draft **must not exceed - 0.10” W.C. (-24.9 Pa)**. These factors must be planned into the vent installation. If the maximum allowable equivalent lengths of piping are exceeded, the unit will not operate properly or reliably.

### 2.14 COMBUSTION AIR

The AERCO Gas-Fired Heater Venting and Combustion Air Guide, GF-5050 **MUST** be consulted before any flue or inlet air venting is designed or installed. Air supply is a direct requirement of ANSI 223.1, NFPA-54, CSA B149.1 and local codes. These codes should be consulted before a permanent design is determined.

The combustion air **MUST** be free of chlorine, halogenated hydrocarbons or other chemicals that can become hazardous when used in gas-fired equipment. Common sources of these compounds are swimming pools, degreasing compounds, plastic processing, and refrigerants. Whenever the environment contains these types of chemicals, combustion air **MUST** be supplied from a clean area outdoors for the protection and longevity of the equipment and warranty validation.

The more common methods of combustion air supply are outlined in the following sections. For combustion air supply from ducting, see Section 2.15: *Ducted Combustion*.

#### 2.14.1 Combustion From Outside the Building

Air supplied from outside the building must be provided through two permanent openings. For each unit these two openings must have a free area of not less than one sq. in. (6.45 sq. cm) for each 4000 BTUs (1.172 kW) input of the equipment or 250 sq. in. (1613 sq. cm) of free area. The free area must take into account restrictions such as louvers and bird screens.

#### 2.14.2 Combustion Air from Inside the Building

When combustion air is provided from within the building, it must be supplied through two permanent openings in an interior wall. Each opening must have a free area of not less than one sq. in. (6.45 sq. cm) per 1000 BTU (0.293 kW) of total input or 1000 sq. in. (6,451 sq. cm) of free area. The free area must take into account any restrictions, such as louvers.

### 2.15 DUCTED COMBUSTION

The AERCO Innovation Water Heater is suitable for 100%-ducted combustion air. For ducted combustion air installations, the inlet air ductwork must then be attached directly to the unit's air inlet.

In a ducted combustion air application, the combustion air ducting pressure losses must be taken into account when calculating the total maximum allowable venting run. See the AERCO Innovation Venting and Combustion Air Guide, GF-5050. When using the heater in a ducted combustion air configuration, each unit must have a minimum 6 inch (15.24 cm) diameter connection at the unit.



## CHAPTER 3. OPERATION

### 3.1 INTRODUCTION

The information in this Chapter provides a guide to the operation of the Innovation Water Heater using the Control Panel mounted on the front of the unit. It is imperative that the initial startup of this unit be performed by factory trained personnel. Operation prior to initial startup by factory trained personnel will void the equipment warranty. In addition, the following WARNINGS and CAUTIONS must be observed at all times.

#### CAUTION!

All of the installation procedures in Chapter 2 must be completed before attempting to start the unit.

#### WARNING!

ELECTRICAL VOLTAGES IN THIS SYSTEM INCLUDE **220, 110 AND 24 VOLTS AC**. IT MUST BE SERVICED ONLY BY FACTORY CERTIFIED SERVICE TECHNICIANS.

#### WARNING!

**DO NOT ATTEMPT TO DRY FIRE THE UNIT.** STARTING THE UNIT WITHOUT A FULL WATER LEVEL CAN SERIOUSLY DAMAGE THE UNIT AND MAY RESULT IN INJURY TO PERSONNEL OR PROPERTY DAMAGE. THIS SITUATION WILL VOID ANY WARRANTY.

### 3.2 CONTROL PANEL DESCRIPTION

The Innovation Control Panel shown in Figure 3-1 contains all of the controls, indicators and displays necessary to operate, adjust and troubleshoot the Innovation Water Heater. These operating controls, indicators and displays are listed and described in Table 3-1. Additional information on these items is provided in the individual operating procedures provided in this Chapter.

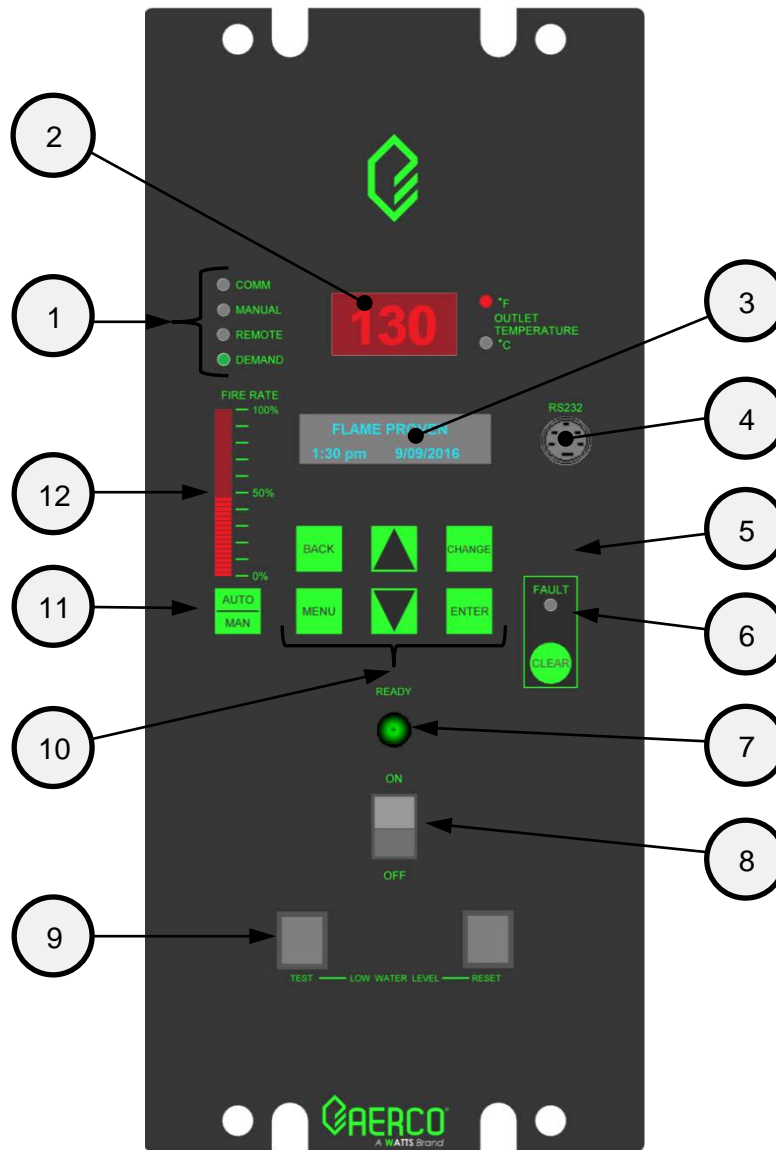


Figure 3-1. Control Panel Front View

**TABLE 3-1: CONTROLS, INDICATORS, AND DISPLAYS (ref. Figure 3-1)**

ITEM	CONTROL, INDICATOR or DISPLAY	FUNCTION
<b>LED STATUS INDICATORS</b>		
Four Status LEDs indicate the current operating status as follows:		
<b>1</b>	<b>COMM =</b>	Lights when RS232 communication is occurring – see Item 4.
	<b>MANUAL =</b>	Lights when the valve position (fire rate) is being controlled using the front panel keypad. This mode of operation is for service technician use only.
	<b>REMOTE =</b>	Lights when the unit is being controlled by an external signal from an Energy Management System.
	<b>DEMAND =</b>	Lights when there is a demand for heat.
<b>2</b>	<b>OUTLET TEMPERATURE</b> Display	3-Digit, 7-Segment LED display continuously displays the outlet water temperature. The °F or °C LED next to the display lights to indicate whether the displayed temperature is in degrees Fahrenheit or degrees Celsius. The °F or °C blinks when operating in the DEADBAND mode.
<b>3</b>	<b>VFD Display</b>	Vacuum Fluorescent Display (VFD) consists of 2 lines each capable of displaying up to 16 alphanumeric characters. The information displayed includes: <ul style="list-style-type: none"> <li>• Startup Messages</li> <li>• Fault Messages</li> <li>• Operating Status Messages</li> <li>• Menu Selection</li> </ul>
<b>4</b>	<b>RS232 Port</b>	This port is used only by factory-trained personnel to monitor onAER communications, in combination with the RS232 Adaptor Cable (P/N <b>124675</b> ).
<b>5</b>	<b>FAULT</b> Indicator	Red <b>FAULT</b> LED indicator lights when an alarm condition occurs. An alarm message will appear in the VFD.
<b>6</b>	<b>CLEAR</b> Key	Turns off the <b>FAULT</b> indicator and clears the alarm message if the alarm is no longer valid. Lockout type alarms will be latched and cannot be cleared by simply pressing this key. Troubleshooting may be required to clear these types of alarms.
<b>7</b>	<b>READY</b> Indicator	Lights when ON/OFF switch is set to <b>ON</b> and when all Pre-Purge conditions have been satisfied.
<b>8</b>	<b>ON/OFF</b> switch	Enables and disables water heater operation.
<b>9</b>	<b>LOW WATER LEVEL TEST/RESET</b> switches	<ul style="list-style-type: none"> <li>• Allows operator to test operation of the water level monitor.</li> <li>• Pressing <b>TEST</b> opens the water level probe circuit and simulates a Low Water Level alarm.</li> <li>• Pressing <b>RESET</b> resets the water level monitor circuit.</li> <li>• Pressing the <b>CLEAR</b> key (item 6) resets the display.</li> </ul>

**TABLE 3-1: CONTROLS, INDICATORS, AND DISPLAYS (ref. Figure 3-1)**

ITEM	CONTROL, INDICATOR or DISPLAY	FUNCTION
<b>10</b>	<b>MENU KEYPAD</b>	
	Six (6) keys which provide the following functions for the Control Panel menus:	
	<b>MENU</b>	Steps through the main menu categories shown in Figure 3-2. The menu categories wrap around in the order shown.
	<b>BACK</b>	Allows you to go back to the previous menu level without changing any information. Continuously pressing this key will bring you back to the default status display in the VFD. Also, this key allows you to go back to the top of a main menu category.
	▲ (UP) Arrow	When in one of the main menu categories (Figure 3-2), pressing the ▲ arrow key will select the displayed menu category. If the <b>CHANGE</b> key was pressed and the menu item is flashing, pressing the ▲ arrow key will increment the selected setting.
	▼ (DOWN) Arrow	When in one of the main menu categories (Figure 3-2), pressing this key will select the displayed menu category. If the <b>CHANGE</b> key was pressed and the menu item is flashing, pressing the ▼ arrow key will decrement the selected setting.
	<b>CHANGE</b>	Permits a setting to be changed (edited). When the <b>CHANGE</b> key is pressed, the displayed menu item will begin to flash. Pressing the ▲ or ▼ arrow key when the item is flashing will increment or decrement the displayed setting.
<b>ENTER</b>	Saves the modified menu settings in memory. The display will stop flashing.	
<b>11</b>	<b>AUTO/MAN</b> switch	<p>This switch toggles the water heater between the AUTOMATIC and MANUAL modes of operation. When in the MANUAL (<b>MAN</b>) mode, the front panel controls are enabled and the <b>MANUAL</b> status LED lights. Manual operation is for service only.</p> <p>When in the AUTOMATIC (<b>AUTO</b>) mode, the <b>MANUAL</b> status LED will be off and the front panel controls disabled.</p>
<b>12</b>	<b>VALVE POSITION</b> Bargraph	20 segment red LED bargraph continuously shows the Air/Fuel Valve position in 5% increments from 0 to 100%

### 3.3 CONTROL PANEL MENUS

The Control Panel incorporates an extensive menu structure which permits the operator to set up, and configure the unit. The menu structure consists of five major menu categories which are applicable to this manual. These categories are shown in Figure 3-2. Each of the menus shown, contain options which permit operating parameters to be viewed or changed. The menus are protected by password levels to prevent unauthorized use.

Prior to entering the correct password, the options contained in the Operation, Setup, Configuration and Tuning menu categories can be viewed. However, with the exception of Internal Setpoint Temperature (Configuration menu), none of the viewable menu options can be changed.

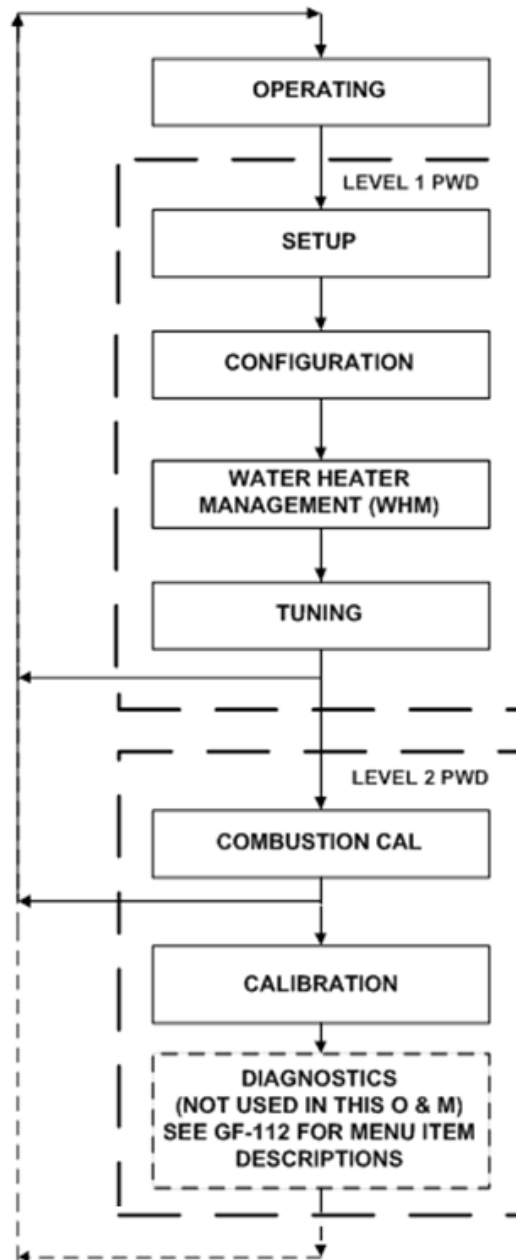
Once the valid level 1 password (159) is entered, the options listed in the Setup, Configuration, Water Heater Management (WHM) and Tuning menus can be viewed and changed, if desired.

#### 3.3.1 Menu Processing Procedure

Accessing and initiating each menu and option is accomplished using the menu keys shown in Figure 3-1. Therefore, it is imperative that you be thoroughly familiar with the following basic steps before attempting to perform specific menu procedures.

#### MENU PROCESSING PROCEDURE Instructions

1. The Control Panel will normally be in the Operating menu and the VFD will display the current unit status. Pressing the ▲ or ▼ arrow key will display the other available data items in the Operating menu.
2. Press the **MENU** key. The display will show the Setup menu, which is the next menu category shown in Figure 3-2. This menu contains the Password option which must be entered if other menu options will be changed.
3. Continue pressing the **MENU** key until the desired menu is displayed.
4. With the desired menu displayed, press the ▲ or ▼ arrow key. The first option in the selected menu will be displayed.
5. Continue to press the ▲ or ▼ arrow key until the desired menu option is displayed. Pressing the ▲ arrow key will display the available menu options in the Top-Down sequence. Pressing the ▼ arrow key will display the options in the Bottom-Up sequence. The menu options will wrap-around after the first or last available option is reached.
6. To change the value or setting of a displayed menu option, press the **CHANGE** key. The displayed option will begin to flash. Press the ▲ or ▼ arrow key to scroll through the available menu option choices for the option to be changed. The menu option choices do not wrap around.
7. To select and store a changed menu item, press the **ENTER** key.



**NOTE**  
The WHM menu is only displayed when the Unit Type in the Configuration Menu is set to INNOVATION WH.

**Figure 3-2: Menu Structure**

**NOTE:**

The following sections provide brief descriptions of the options contained in each menu. Refer to Appendix A for detailed descriptions of each menu option. Refer to Appendix B for listings and descriptions of displayed startup, status and error messages.

### 3.4 OPERATING MENU

The Operating menu displays a number of key operating parameters for the unit, as listed in Table 3-2. This menu is “Read-Only” and does not allow personnel to change or adjust any displayed items. It can therefore be viewed at any time without entering a password. Pressing the ▲ arrow key to display the menu items in the order listed (top-down). Pressing the ▼ arrow key will display the menu items in reverse order (bottom-up).

A full description of each item appears in Table A-1 of Appendix A – Innovation Menu Item Descriptions.

**Table 3-2: OPERATING Menu**

MENU ITEM DISPLAY		AVAILABLE CHOICES OR LIMITS		Appears Only If Enabled in:
		Minimum	Maximum	
1	Active Setpoint	40°F (4.4°C)	240°F (116°C)	
2	Outlet Temp	30°F (-1.1°C)	240°F (116°C)	Calibration Menu
3	Inlet Temp	30°F (-1.1°C)	240°F (116°C)	Calibration Menu
4	Air Temp	-70°F (-56.7°C)	245°F (118°C)	
5	Outdoor Temp	-70°F (-56.7°C)	130°F (54.4°C)	Configuration Menu
6	Valve Position In	0%	100%	
7	Valve Position Out	0%	100%	Calibration Menu
8	FFWD Temp	30°F (-1.1°C)	240°F (115.6°C)	
9	Exhaust Temp	Displays current exhaust temperature		Calibration Menu
10	Flame Strength	0%	100%	
11	Min Flame Str	Not Used		
12	O2 Monitor	Enable	Disable	
13	Oxygen Level	0%	21%	
14	Ignition Time	0.00	10.00	
15	SSOV Time to OPN	0.00	10.00	
16	Spark Current	0 amps	2.5 amps	
17	Run Cycles	0	999,999,999	
18	Run Hours	0	999,999,999	
19	Fault Log	0	19	

**\* NOTE:**

The Outdoor Temp setting (Item 5) will not be displayed unless the Outdoor Sensor function has been enabled in the Configuration menu (Table 3-4).

### 3.5 SETUP MENU

The Setup menu permits the operator to enter the unit password (159) which is required to change the menu options. To prevent unauthorized use, the password will time-out after 1 hour. Therefore, the correct password must be reentered when required. In addition to permitting password entries, the Setup menu is also used to enter date and time, and units of temperature measurements. A view-only software version display is also provided to indicate the current C-More Controller software version.

A full description of each item appears in Table A-2 of Appendix A – Innovation Menu Item Descriptions.

<b>Table 3-3: SETUP Menu</b>				
<b>MENU ITEM DISPLAY</b>		<b>AVAILABLE CHOICES OR LIMITS</b>		<b>DEFAULT</b>
		<b>Minimum</b>	<b>Maximum</b>	
<b>1</b>	Password	0	9999	0
<b>2</b>	Language	English		English
<b>3</b>	Time	12:00 am	11:59 pm	12:00
<b>4</b>	Date	01/01/00	12/31/99	01/01/00
<b>5</b>	Unit of Temp	Fahrenheit or Celsius		Fahrenheit
<b>6</b>	Comm Address	0	127	0
<b>7</b>	Baud Rate	2400, 4800, 9600, 19.2K		9600
<b>8</b>	onAER Mode	Ethernet or SD Card		Ethernet
<b>9</b>	Min Upload Timer	0	9,999 Sec	0
<b>10</b>	Unit Alpha	E, G, H, R, N or A		A
<b>11</b>	Unit Year	0	99	0
<b>12</b>	Unit Serial #	0	9999	0
<b>13</b>	Software	Ver 0.00	Ver 9.99	Current software version

### 3.6 CONFIGURATION MENU

The Configuration menu permits adjustment of the Internal Setpoint (Setpt) temperature regardless of whether the valid password has been entered. Setpt is required for operation in the Constant Setpoint mode. The remaining options in this menu require the valid password to be entered, prior to changing existing entries. This menu contains a number of other configuration settings which may or may not be displayed, depending on the current operating mode setting.

A full description of each item appears in Table A-3 of Appendix A – Innovation Menu Item Descriptions.



# Innovation Installation, Operation & Maintenance – KOREA EDITION

## CHAPTER 3 – OPERATION

**NOTE:**

The Configuration menu settings shown in the table below are Factory-Set in accordance with the requirements specified for each individual order. Therefore, under normal operating conditions, no changes will be required.

<b>Table 3-4. Configuration Menu</b>				
<b>MENU ITEM DISPLAY</b>		<b>AVAILABLE CHOICES OR LIMITS</b>		<b>DEFAULT</b>
		<b>Minimum</b>	<b>Maximum</b>	
<b>1</b>	Internal Setpt	Lo Temp Limit	Hi Temp Limit	130°F (54.4°C)
<b>2</b>	Unit Type	KC WH, KC WH LN, Innovation WH		Innovation WH
<b>3</b>	Unit Size	600, 800, 1060, 1400 MBH (175.8, 234.5, 310.7, 410.3 kW)		600, 800, 1060 or 1400 MBH
<b>4</b>	Fuel Type	Natural Gas, Propane		Natural Gas
<b>5</b>	Heater Mode	Constant Setpoint, Remote Setpoint,		Constant Setpoint
<b>6</b>	Remote Signal (If Mode = Remote Setpoint, Direct Drive or Combination)	4 – 20 mA/1 – 5V 0 -20 mA/0 – 5V PWM Input (Legacy BMS), Network		4 – 20 mA, 1-5V
<b>7</b>	Outdoor Sensor	Enabled or Disabled		Disabled
<b>8</b>	System Start Tmp (If Outdoor Sensor =Enabled)	30°F (-1.1°C)	100°F (37.8°C)	60°F (15.5°C)
<b>9</b>	Setpt Lo Limit	40°F (4.4°C)	Setpt Hi Limit	60°F (15.5°C)
<b>10</b>	Setpt Hi Limit	Setpt Lo Limit	190°F (87.8°C)	150°F (65.6°C)
<b>11</b>	Temp Hi Limit	40°F (4.4°C)	200°F (93.3°C)	160°F (71.1°C)
<b>12</b>	Max Valve Position	40%	100%	100%
<b>13</b>	Pump Delay Timer	0 min.	30 min.	0 min.
<b>14</b>	Aux Start On Dly	0 sec.	240 sec.	0 sec.
<b>15</b>	Failsafe Mode	Shutdown or Constant Setpt		Shutdown
<b>16</b>	* Analog Output	Off, Setpoint, Outlet Temp, Valve Pos 4-20mA, valve Pos 0-10v		Valve Pos 0-10v
<b>17</b>	Low Fire Timer	2 sec.	600 sec.	2 sec.
<b>18</b>	Setpt Limiting	Enabled or Disabled		Disabled
<b>19</b>	Setpt Limit Band	0°F (0°C)	10°F (5.5°C)	0
<b>20</b>	Network Timeout	5 Sec	999 Sec	30 Sec

<b>Table 3-4. Configuration Menu</b>				
<b>MENU ITEM DISPLAY</b>		<b>AVAILABLE CHOICES OR LIMITS</b>		<b>DEFAULT</b>
		<b>Minimum</b>	<b>Maximum</b>	
<b>21</b>	Shutoff Dly Temp	0	25	8
<b>22</b>	Demand Offset	0	25	5
<b>23</b>	Deadband High	0	25	0
<b>24</b>	Deadband Low	0	25	0
<b>25</b>	IGST Version	V2.00 or Lower	V2.02	0
<b>26</b>	IGN Timing Setting	4 Sec	7 Sec	-
<b>27</b>	Diag Valve Pos 1	0	100	35
<b>28</b>	Diag Valve Pos 2	0	100	45
<b>29</b>	Diag Valve Pos 3	0	100	55
<b>30</b>	Diag Valve Pos 4	0	100	65
<b>31</b>	Diag Valve Pos 5	0	100	75
<b>32</b>	Ignited Time	1 sec.	9999 sec.	30 sec.
<b>33</b>	Off Time	0 sec.	9999 sec.	5 sec.
<b>34</b>	Diag Loop Repeat	0	9999	0
<b>35</b>	Self Diag RUN	Enable	Disable	Disable
<b>36</b>	VP Loop Time	Displays current reading		
<b>37</b>	Highest Ign Time	Displays current reading		

**CAUTION!**

\* **DO NOT CHANGE** the Analog Output menu item from its Default setting, **Valve Pos 0-10V**.

### 3.7 TUNING MENU

The Tuning menu items in Table 3-5 are Factory set for each individual unit. Do not change these menu entries unless specifically requested to do so by factory-trained personnel.

A full description of each item appears in Table A-4 of Appendix A – Innovation Menu Item Descriptions.

**Table 3-5. Tuning Menu**

MENU ITEM DISPLAY		AVAILABLE CHOICES OR LIMITS		DEFAULT
		Minimum	Maximum	
1	Prop Band	1°F (0.55°C)	120°F (66°C)	70°F (21.1°C)
2	Integral Gain	0.00	10.00	3.00
3	Derivative Time	0.00 min	2.00 min	0.20 min
4	Min Load Adj (an offset)	-50°F (-27.5°C)	+50°F (27.5°C)	0°F (0°C)
5	Max Load Adj (an offset)	-50°F (-27.5°C)	+50°F (27.5°C)	0°F (0°C)
6	FFWD Temp	30°F (-1.1°C)	245°F (118.3°C)	Read Only Value
7	Outlet Feedback	Yes (On) or No (Off)		Yes (On)
8	Feedback Gain	0.01	1.00	0.10
<b>Breakpoints</b> – shown only if the Heatr Bkpt Dsp option in the Calibration Menu is Enabled (see Section 3-8). The Breakpoint values correspond to a 130°F default setpoint				
9	Breakpt at 100%	30°F (-1.1°C)	240°F (115.6°C)	85°F (29.4°C)
10	Breakpt at 90%	30°F (-1.1°C)	240°F (115.6°C)	86°F (30°C)
11	Breakpt at 80%	30°F (-1.1°C)	240°F (115.6°C)	87°F (30.5°C)
12	Breakpt at 70%	30°F (-1.1°C)	240°F (115.6°C)	88°F (31.1°C)
13	Breakpt at 60%	30°F (-1.1°C)	240°F (115.6°C)	89°F (31.7°C)
14	Breakpt at 50%	30°F (-1.1°C)	240°F (115.6°C)	90°F (32.2°C)
15	Breakpt at 40%	30°F (-1.1°C)	240°F (115.6°C)	94°F (34.4°C)
16	Breakpt at 30%	30°F (-1.1°C)	240°F (115.6°C)	103°F (39.4°C)
17	Breakpt at 20%	30°F (-1.1°C)	240°F (115.6°C)	118°F (47.8°C)
18	Breakpt at 10%	30°F (-1.1°C)	240°F (115.6°C)	134°F (56.7°C)
19	Breakpt at 0%	30°F (-1.1°C)	240°F (115.6°C)	136°F (57.8°C)
20	Warmup Prop Band	1°F (0.55°C)	120°F (66°C)	70°F (21.1°C)
21	Warmup Int Gain	0.00	2.00	0.50
22	Warmup PID timer	0 sec.	240 sec.	20 sec.
<b>The following items appear only with password level 3 or higher</b>				
23	FDbkck Start Pos	0%	100%	30%
24	Fdbkck End Pos	0%	100%	60%

<b>Table 3-5. Tuning Menu</b>				
<b>MENU ITEM DISPLAY</b>		<b>AVAILABLE CHOICES OR LIMITS</b>		<b>DEFAULT</b>
		<b>Minimum</b>	<b>Maximum</b>	
<b>25</b>	Max Feedback	0%	100%	30%
<b>26</b>	Fdback Value	0%	100%	Read Only Value
<b>27</b>	Temp Gov	Enable or Disable		Enable
<b>28</b>	GOV Limit-5	0	100	30
<b>29</b>	GOV Limit-7	0	100	20
<b>30</b>	GOV Limit-10	0	100	15
<b>31</b>	GOV Limit-12	0	100	10
<b>32</b>	GOV Limit-15	0	100	5
<b>33</b>	PID Output	0%	100%	Read Only Value
<b>34</b>	P Output	0%	100%	Read Only Value
<b>35</b>	I Output	0%	100%	Read Only Value
<b>36</b>	D Output	0%	100%	Read Only Value
<b>37</b>	Above 70F Val	For Use By Factory Trained Personnel Only!		
<b>38</b>	Below 70F Val	For Use By Factory Trained Personnel Only!		
<b>39</b>	Reset Defaults?	Yes	No	No

### 3.8 CALIBRATION MENU

The Calibration menu is used by factory trained service personnel to adjust or reset the parameters listed below.

A full description of each item appears in Table A-5 of Appendix A – Innovation Menu Item Descriptions.

<b>Table 3-6: Calibration Menu</b>				
<b>MENU ITEM DISPLAY</b>		<b>AVAILABLE CHOICES OR LIMITS</b>		<b>DEFAULT</b>
		<b>Minimum</b>	<b>Maximum</b>	
<b>1</b>	Stepper Fbk	Cal 0%, Cal 100% Verify 50%		Cal 0%
<b>2</b>	Purge Timer	5 sec.	60 sec	Depends on unit type/size
<b>3</b>	Post Purge Timer	0 sec.	60 sec.	0 sec.
<b>4</b>	IGN Position	5%	60%	Depends on unit type/size
<b>5</b>	FFWD Temp Dsply	Enabled or Disabled		Disabled
<b>6</b>	Outlet Tmp Dsply	Enabled or Disabled		Disabled
<b>7</b>	Inlet Tmp Dsply	Enabled or Disabled		Disabled
<b>8</b>	Valv Pos Out Dsp	Enabled or Disabled		Enabled

# Innovation Installation, Operation & Maintenance – KOREA EDITION

## CHAPTER 3 – OPERATION

**Table 3-6: Calibration Menu**

MENU ITEM DISPLAY		AVAILABLE CHOICES OR LIMITS		DEFAULT
		Minimum	Maximum	
9	Exhaust Tmp Dsp	Enabled or Disabled		Disabled
10	Exhaust Safety	Enabled or Disabled		Enabled
11	Flue Material	PVC	Stainless	PVC
12	Exhst Fault Temp	100 °F	500 °F	200 °F
13	Exhst Module Temp	100 °F	500 °F	190 °F
14	Exhst Warn Temp	100 °F	500 °F	180 °F
15	Exhst Tmp VP Adj	0	10	5
16	Exhst Adj Rate	1	600	30
17	VP Up Rate	0.5	60.0	Depends on unit type/size
18	VP Down Rate	0.5	60.0	Depends on unit type/size
19	Purge Blwr Offst	-1.0	8.0	Depends on unit type/size
20	4-20mA Purge Pct	60%	100%	70%
21	PWM In Adj	-5.0%	5.0%	0.0%
22	Analog In Adj	-5.0%	5.0%	0.0%
23	Flow In Adj	-5.0%	5.0%	0.0%
24	Supply Gas Pressure In Adj	-5.0%	5.0%	0.0%
25	Gas Plate dp In Adj	-5.0%	5.0%	0.0%
26	mA Out Adj	-5.0 mA	5.0 mA	0.0 mA
27	A/F Sensitivity	1%	5%	2%
28	Power Reset	Automatic or Manual		Automatic
29	Water Temp Reset	Automatic or Manual		Automatic
30	Gas Press Reset	Automatic or Manual		Manual
31	Min Off Time	0 Min	15 Min	0 Min
32	Heatr Tuning Dsp	Enabled or Disabled		Disabled
33	Heatr Bkpt Dsp	Enabled or Disabled		Disabled
34	Stop Level	0%	Start Level	16
35	Start Level	Stop Level	40%	20
36	Skip Range Cntr	10	95	40
37	Skip Range Span	0.5	3	0
38	Skip Speed	5	20	5
39	O2 Gain	920	1126	1024
40	O2 Offset	-3.0	+3.0	0
41	O2 Sensor	Enabled or Disabled		Depends on unit type/size
42	Cal Temp Sensors	Off or Start		Off
43	FFWD Temp Offset	-20	+20	0

**Table 3-6: Calibration Menu**

MENU ITEM DISPLAY		AVAILABLE CHOICES OR LIMITS		DEFAULT
		Minimum	Maximum	
44	Exhst Tmp Offset	-20	+20	0
45	Outdr Air Offset	-20	+20	0
46	Inlet Air Offset	-20	+20	0
47	Inlet Wtr Offset	-20	+20	0
48	Outlet Wtr Offset	-20	+20	0
49	24 hr Max Cycles	0	9999	0
50	24 hr Max Ovrtmp	0	9999	0
51	0-10v Out Test	0	1000	0
52	Spark Monitor	Enabled or Disabled		Depends on unit type/size
53	Min Spark Amps	0 Amps	2.5 Amps	0.1 Amps
54	Max Spark Amps	0 Amps	2.5 Amps	0.4 Amps

### 3.9 START SEQUENCE

When the C-More Controller ON/OFF switch is set to the **ON** position, it checks all pre-purge safety switches to ensure they are closed. These switches include:

- Safety Shut-Off Valve **Proof of Closure** (POC) switch
- **Low Water Level** switch
- **High Water Temperature** switch
- **High Gas Pressure** switch
- **Low Gas Pressure** switch

**NOTE:**

The **Blocked Inlet** and downstream **Blower Proof** switches are *not* checked prior to starting the pre-purge.

If all of the above switches are closed, the **READY** light above the ON/OFF switch will light and the unit will be in the Standby mode.

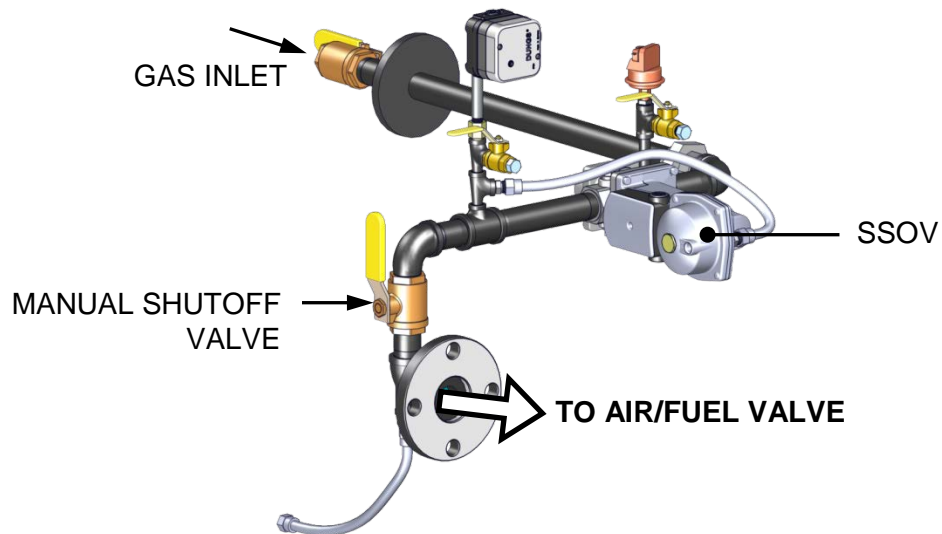
When there is a demand for hot water, the following events will occur:

**NOTE:**

If any of the Pre-Purge safety device switches are open, the appropriate fault message will be displayed. Also, if the required conditions are not observed at any point during the start sequence, appropriate messages will be displayed and the unit will go into fault mode.

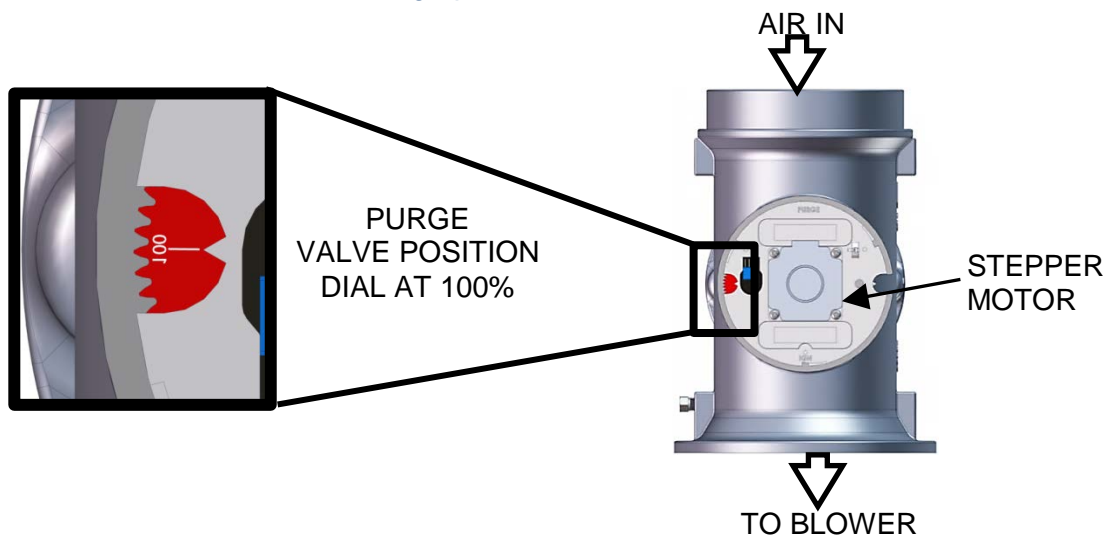
**START SEQUENCE Instructions**

1. The **DEMAND** LED status indicator will light.
2. The unit checks to ensure that the **Proof of Closure** (POC) switch in the downstream Safety Shut-Off Valve (SSOV) is closed. See Figure 3-3 for SSOV location.
3. The **DEMAND** LED status indicator will light.
4. The unit checks to ensure that the **Proof of Closure** (POC) switch in the downstream Safety Shut-Off Valve (SSOV) is closed. See Figure 3-3 for SSOV location.



**Figure 3-3. SSOV Location (INN600–1060 Gas Train shown)**

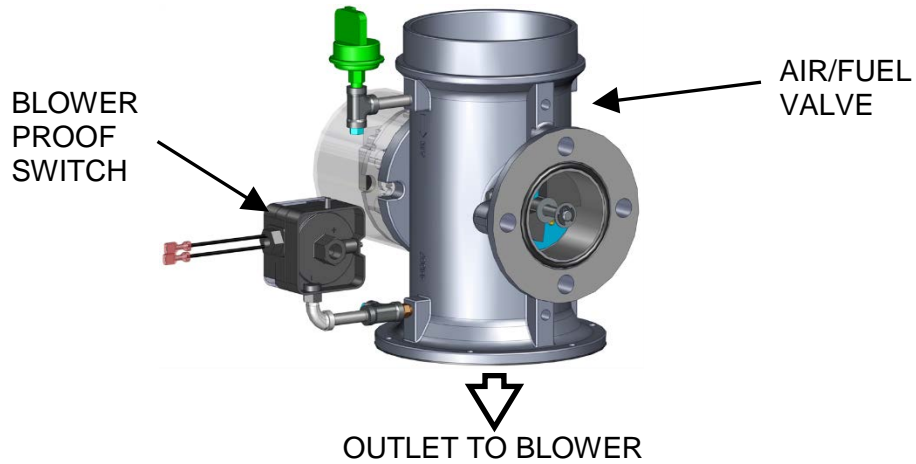
5. With all required safety device switches closed, a purge cycle will be initiated and the following events will occur:
  - a. The Blower relay energizes and turns on blower.
  - b. The Air/Fuel Valve rotates to the full-open purge position and closes purge position switch. The dial on the Air/Fuel Valve (Figure 3-4) will read **100** to indicate that it is full-open (100%).
  - c. The **VALVE POSITION** bargraph will show 100%.



**Figure 3-4: Air/Fuel Valve in Purge Position**

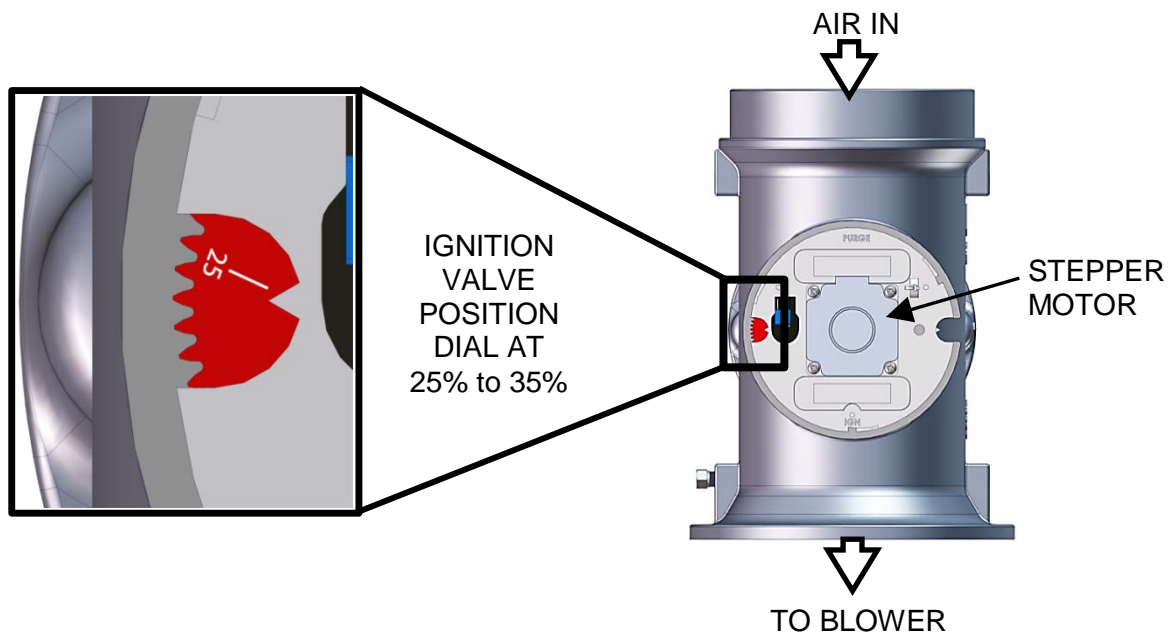
**START SEQUENCE Instructions**

6. Next, the **Blower Proof** switch on the Air/Fuel Valve (Figure 3-5) closes. The display will show **PURGING** and indicate the elapsed time of the purge cycle in seconds.



**Figure 3-5: Blower Proof Switch**

7. Upon completion of the purge cycle, the C-More Controller initiates an ignition cycle and the following events occur:
  - a. The Air/Fuel Valve rotates to the low-fire ignition position and closes the **Ignition** switch. The dial on the Air/Fuel Valve (Figure 3-6) will read between **25** and **35** to indicate that the valve is in the low-fire position.
  - b. The igniter-injector relay is activated and provides ignition spark. Current to the igniter or igniter-injector is monitored by the spark monitor (P/N 61034).
  - c. The gas Safety Shut-Off Valve (SSOV) is energized (opened) allowing gas to flow into the Air/Fuel Valve.



**Figure 3-6: Air/Fuel Valve in Ignition Position**



**START SEQUENCE Instructions**

8. Up to 7 seconds will be allowed for ignition to be detected. The igniter-injector relay will be turned off one second after flame is detected.
9. After 2 seconds of continuous flame, **FLAME PROVEN** will be displayed and the flame strength will be indicated. After 5 seconds, the current date and time will be displayed in place of the flame strength.
10. With the unit firing properly, it will be controlled by the temperature controller circuitry. The heater's **VALVE POSITION** will be continuously displayed on the front panel bar-graph.

Once the demand for hot water has been satisfied, the C-More Controller will turn off the SSOV gas valve. The blower relay will be deactivated and the Air/Fuel Valve will be closed. **STANDBY** will be displayed.

**3.10 START/STOP LEVELS**

The ignition position (start) and stop levels are the Air/Fuel Valve positions (% open) that start and stop the unit, based on load. These levels are Factory preset as follows:

Fuel	Model	Stop Level	Ignition Position
Natural Gas	All	16%	26%
Propane	INN600	16%	26%
	INN800	16%	24%
	INN1060	16%	28%
	INN1400	16%	24%

Normally, these settings should not require adjustment.

Note that the energy input is not linearly related to the Air/Fuel Valve position. Refer to Table 3-7 for the relationship between the energy input and Air/Fuel Valve position for a unit running on natural gas.

**Table 3-7. Relationship Between Air/Fuel Valve Position and Energy Input For Units Running Natural Gas**

Air/Fuel Valve Position (% Open)	Innovation Water Heater Model: Energy Input in BTU/Hr. (kWh)			
	INN600	INN800	INN1060	INN1400
16%	45,000 (13.19)	45,000 (13.19)	45,000 (13.19)	45,000 (13.19)
20%	87,000 (25.49)	97,000 (28.42)	97,000 (28.42)	181,000 (53.03)
30%	174,000 (50.98)	192,000 (56.26)	222,000 (65.05)	370,000 (108.4)
40%	243,000 (71.20)	330,000 (96.69)	416,000 (121.9)	665,000 (194.9)
50%	306,000 (89.66)	424,000 (124.2)	520,000 (152.4)	870,000 (254.9)
60%	370,000 (108.4)	486,000 (142.4)	715,000 (209.5)	1,001,000 (293.3)
80%	483,000 (141.5)	615,000 (180.2)	845,000 (247.6)	1,203,000 (352.5)
100%	600,000 (175.8)	800,000 (234.4)	1,060,000 (310.6)	1,350,000 (395.6)

(This Page Is Intentionally Blank)

## **CHAPTER 4. INITIAL START-UP**

### **4.1 INITIAL START-UP REQUIREMENTS**

The requirements for the initial start-up of the Innovation Water Heater consists of the following:

- Complete installation (Chapter 2)
- Set proper controls and limits (Chapter 3)
- Perform combustion calibration (Chapter 4)
- Test safety devices (Chapter 5)

All applicable installation procedures in Chapter 2 must be fully completed prior to performing the initial start-up of the unit. The initial start-up must be successfully completed prior to putting the unit into service. Starting a unit without the proper piping, venting, or electrical systems can be dangerous and may void the product warranty. The following start-up instructions should be followed precisely in order to operate the unit safely and at a high thermal efficiency, with low flue gas emissions.

Initial unit start-up must be performed **ONLY** by AERCO factory trained start-up and service personnel. After performing the start-up procedures in this Chapter, it will be necessary to perform the Safety Device Testing procedures specified in Chapter 5 to complete all initial unit start-up requirements.

An AERCO Gas Fired Startup Sheet, included with each Innovation Heater, must be completed for each unit for warranty validation and a copy must be returned promptly to AERCO at:

**AERCO International, Inc.  
100 Oritani Drive  
Blauvelt, New York 10913  
(FAX: 845-580-8090)**

#### **WARNING!**

**DO NOT ATTEMPT TO DRY FIRE THE HEATER. STARTING THE UNIT WITHOUT A FULL WATER LEVEL CAN SERIOUSLY DAMAGE THE UNIT AND MAY RESULT IN INJURY TO PERSONNEL OR PROPERTY DAMAGE. THIS SITUATION WILL VOID ANY WARRANTY.**

### **4.2 TOOLS AND INSTRUMENTATION FOR COMBUSTION CALIBRATION**

To properly perform combustion calibration, the proper instruments and tools must be used and correctly attached to the unit. The following sections outline the necessary tools and instrumentation as well as their installation.

### 4.2.1 Required Tools & Instrumentation

The following tools and instrumentation are necessary to perform combustion calibration of the unit:

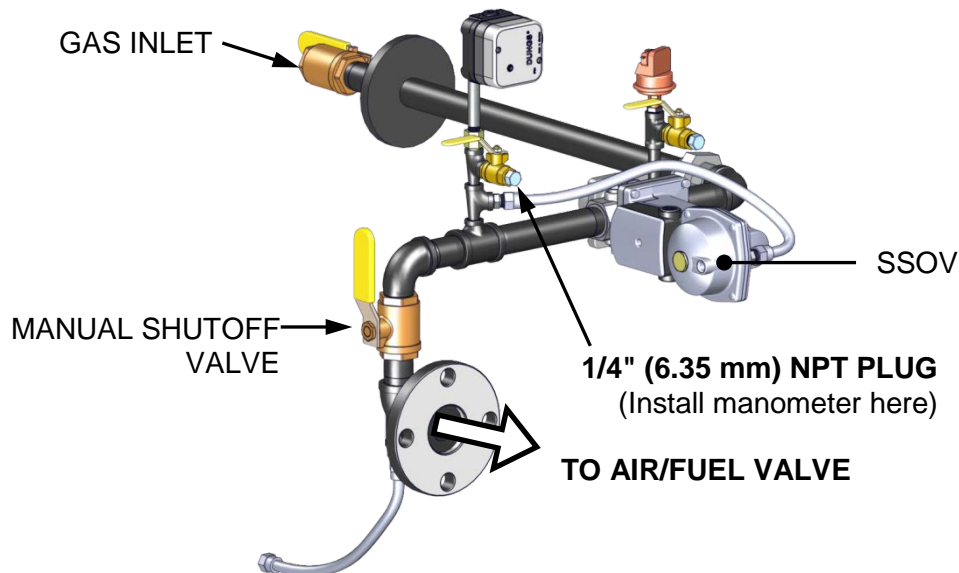
- Digital Combustion Analyzer: Oxygen accuracy to  $\pm 0.4\%$ ; Carbon Monoxide (CO) and Nitrogen Oxide (NOx) resolution to 1 PPM.
- 16 inch W.C. (4.0 kPa) manometer or equivalent gauge and plastic tubing.
- Multimeter (Capable of measuring 0 – 10  $\mu\text{A}$ )
- 1/4 inch NPT-to-barbed fittings for use with gas supply manometer or gauge.
- Small and large flat blade screwdrivers.
- Tube of silicone adhesive

### 4.2.2 Installing Gas Supply Manometer

The gas supply manometer is installed in the gas train as follows:

#### INSTALLING GAS SUPPLY MANOMETER Instructions

1. Close the main manual gas supply shut-off valve upstream of the unit.
2. Remove the front door and left side panels from the heater to access the gas train components.
3. Remove the 1/4 inch NPT pipe plug from the leak detection ball valve on the downstream side of the Safety Shut Off Valve (SSOV) as shown in Figure 4-1.
4. Install a NPT-to-barbed fitting into the tapped plug port.
5. Attach one end of the plastic tubing to the barbed fitting and the other end to the 16 inch W.C. (4.0 kPa) manometer.



**Figure 4-1. 1/4 Inch Gas Plug Location (INN600 – 1060 Gas Train Shown)**

### 4.2.3 Accessing the Analyzer Probe Port

The unit contains a 1/8" NPT port at the rear of the exhaust manifold. This port is located above the condensate drain connection as shown in Figure 4-2. Prepare the port for the combustion analyzer probe as follows:

#### ACCESSING ANALYZER PROBE PORT Instructions

1. Refer to Figure 4-2 and remove the 1/8" NPT plug from the rear of the exhaust manifold.
2. If necessary, adjust the stop on the combustion analyzer probe so it will extend mid-way into the flue gas flow. **DO NOT** install the probe at this time.



**Figure 4-2. Analyzer Probe Hole Location**

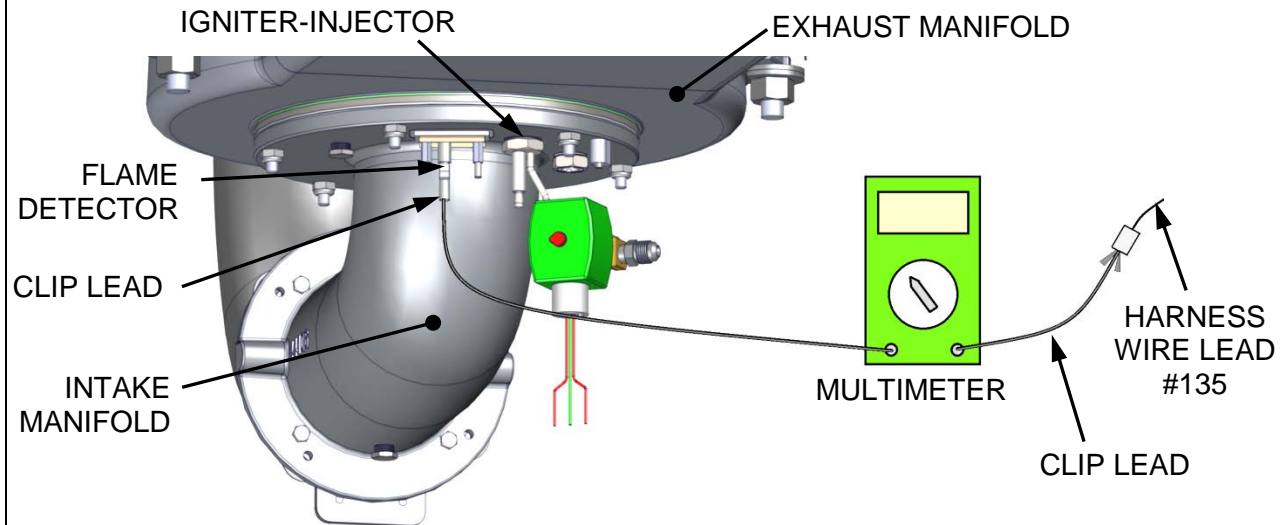
### 4.2.4 Connecting Multimeter to Flame Detector

During Combustion Calibration, the flame strength generated by the flame detector is measured using a multimeter set to the  $\mu\text{A}$  scale. The flame detector is mounted on the intake manifold flange as shown in Figure 4-3.

Proceed as follows to set up the multimeter to measure the flame strength current:

**CONNECTING MULTIMETER TO MEASURE FLAME STRENGTH Instructions**

1. Refer to Figure 4-3 and remove the right side panel from the unit to access the flame detector.
2. Disconnect the flame detector wire lead #135 from the detector and connect the multimeter in series with the wire lead using alligator clips as shown in Figure 4-3.
3. Ensure that the multimeter is set to the  $\mu\text{A}$  scale.



**Figure 4-3. Flame Strength Set-Up Using Multimeter**

**IMPORTANT!**

The unit is shipped from the factory set up for either Natural Gas or Propane, as specified by the Style Number on the Sales Order. Perform the appropriate Combustion Calibration procedures in Section 4.3 for NATURAL GAS, or Section 4.4 for PROPANE.

**4.2.5 Recommendations for Temperature Calibration**

Carefully follow the procedures of Section 4.6 **Temperature Control Calibration**, below, to properly set up the temperature control for the heater. Ignoring this commissioning step may cause water temperature faults, poor water temperature control, and rapid cycling of the heater.

**4.2.6 Recommendations for WHM Operation**

Installations with multiple Innovation units must operate the system in Water Heater Management (WHM) mode (see Section 2.5.1 for instructions on installing the actuator-controlled ball valve). Operation in WHM mode ensures that the system flow will be divided between at least 2 units as demand increases. In addition, WHM ensures that all units receive equal run time and additional water heaters are activated based on the “NEXT ON” firing rate setting.

In case of pre-heated DHW systems with multiple Innovation units, it is highly recommended to lower the “NEXT ON” setting to 30 - 40% (Default = 50%), so that subsequent Water Heaters are engaged sooner to provide more rapid response and divide the system flow over additional units. In case of DHW pre-heat systems, the required temperature rise through an individual unit can be much lower to ensure that flow per unit does not exceed 50 gal. (189 L) per minute at any time.

### 4.3 NATURAL GAS COMBUSTION CALIBRATION

**IMPORTANT!**

The unit is shipped from the factory set up for either Natural Gas or Propane, as specified by the Style Number on the Sales Order. **Complete the instructions below only on units running on NATURAL GAS.**

Innovation Water Heaters are combustion calibrated at the factory prior to shipping. However, recalibration is necessary as part of initial start-up due to changes in the local altitude, gas BTU (kW) content, gas supply piping and supply regulators. Start-Up & Registration Test Data sheets are shipped with each unit. These sheets must be filled out and returned to AERCO for proper Warranty Validation.

It is important to perform the calibration procedure as outlined below, as this will provide optimum performance and keep readjustments to a minimum.

#### NATURAL GAS Combustion Calibration

1. Open the water supply and return valves to the unit and ensure that the system pumps are running.
2. Open the **NATURAL GAS** supply valve(s) to the unit.
3. Set the control panel ON/OFF switch to the **OFF** position.
4. Turn on external AC power to the unit.
5. Enter the password **6817** to continue.
6. Set the unit to the **MANUAL** mode by pressing the **AUTO/MAN** key. A flashing **MANUAL VALVE POSITION** message will be displayed with the present position in %. Also, the **MANUAL LED** will light.
7. Adjust the air/fuel valve position to **0%** by pressing the **▼** arrow key.
8. Ensure that the leak detection ball valve downstream of the SSOV is open.
9. Set the ON/OFF switch to the **ON** position.
10. Change the valve position to **28%** using the **▲** arrow key. The unit should begin its start sequence and fire.
11. Using the **▲** arrow key, increase the valve open position to **100%** and then allow the valve position to reach 100%.
12. With the valve position at 100%, insert the combustion analyzer probe into the 1/8" (3.18 mm) port at the rear of the exhaust manifold. Allow enough time for the combustion analyzer to settle.
13. Check the gas pressure downstream of the SSOV. The pressure is factory set for full rated input, and then recorded in the Max Fire Pressure column on the Manifold Gas Pressure Setting Tag hanging near the SSOV. If the gas pressure **is not** within  $\pm 0.2$ " W.C. of the **last** recorded on the Tag, you must complete Step 14 and 15, below, to adjust the gas pressure. The pressure should be within the range shown in Table 4-1:

**TABLE 4-1: NATURAL GAS Pressure Downstream of SSOV**

Innovation 600	1.0" – 2.0" W.C. (249 – 498 Pa)
Innovation 800	1.0" – 2.0" W.C. (249 – 498 Pa)
Innovation 1060	2.0" – 3.2" W.C. (498 – 797 Pa)
Innovation 1400	2.9" – 3.9" W.C. (722 – 971 Pa)

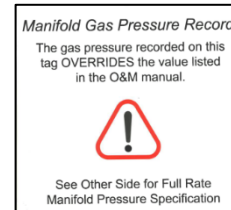


**NATURAL GAS Combustion Calibration**

Unit SN: \_\_\_\_\_ - \_\_\_\_\_ - \_\_\_\_\_

Only Record a new gas pressure setting if  $\pm 0.2''\text{wc}$  different than last value recorded

Date	Max Fire Pressure ("wc)	High Gas Switch Set ("wc)	O <sub>2</sub> %	Tech Name & Company
				Factory Calibration
				(Field Start-up)



(Back of Tag)

**Figure 4-4. Manifold Gas Pressure Setting Tag (Front and Back)**

- If the gas pressure downstream of the SSOV is **not** within  $\pm 0.2''$  W.C. of the pressure listed on the Manifold Gas Pressure Setting tag, remove the brass hex nut on the SSOV actuator to access the gas pressure adjustment screw. Slowly rotate the screw in approximately 1/4-turn increments **clockwise** to **increase** the gas pressure, **counter-clockwise** to the **reduce** gas pressure, as needed, to reach the value on the tag. Do not allow the pressure to fall outside the range in Table 4-1.



BRASS HEX HEAD CAP

(Remove cap to access gas pressure adjustment screw)

**Figure 4-5. SSOV Gas Pressure Adjustment Screw Location**

- If it was removed in the previous step, replace the brass hex cap on the SSOV.
- Press the **MENU** key on the front panel of the C-More until **COMBUSTION CAL MENU** appears on the display.
- Navigate to the **SET Stdby V Out (Standby Voltage)** setting and verify that it is set to **2.0 V**. AERCO recommends that it be kept at 2.0 volts to prevent flue gas recirculation.
- Press the **▲** arrow key until **Set Valve Position** reads **100%**, then press the **ENTER** key.
- Press the **CHANGE** key and observe that **CAL VOLTAGE 100%** is flashing.
- The oxygen level at the 100% valve position should match the value in Table 4-2, below. You may need increase the O<sub>2</sub>% above this range to meet ultra-low NO<sub>x</sub> requirements or to avoid combustion tone issues. Also, ensure that the nitrogen oxide (NO<sub>x</sub>), carbon monoxide (CO) and flame strength readings match the values shown in Table 4-2.
- If the oxygen level is not within the specified range, adjust the level using the **▲** and **▼** arrow keys. This will adjust the output voltage to the blower motor as indicated on the display. Press the **▲** arrow key to **increase** the oxygen level or press the down **▼** arrow key to **decrease** the oxygen level.
- Once the oxygen level is within the specified range at 100%, press the **ENTER** key to store the selected blower output voltage for the 100% valve position. Record all readings on the Combustion Calibration Sheets provided.



**NATURAL GAS Combustion Calibration**

**NOTE**

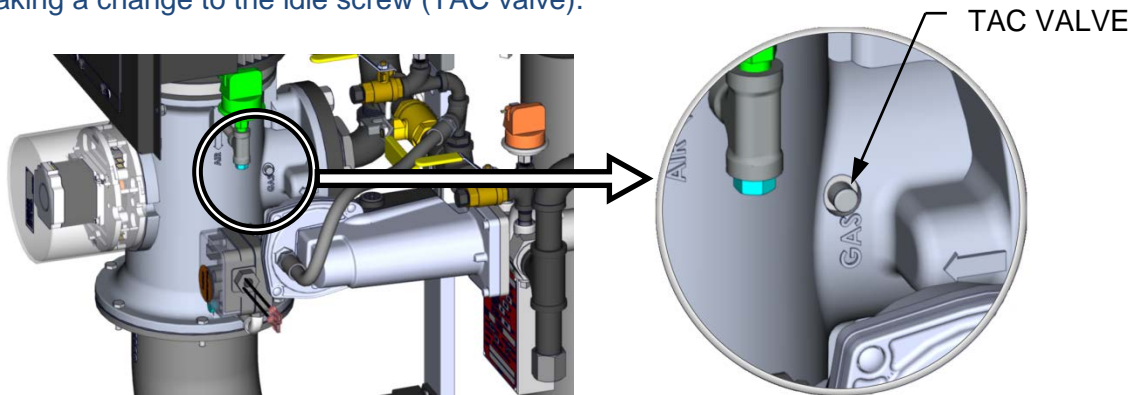
If NOx readings exceed the target value in Table 4-2 (<20 ppm), increase the O<sub>2</sub> level up to 25% higher than the value listed in Table 4-2, and then record the increased O<sub>2</sub> value on the Combustion Calibration sheet.

23. Repeat steps 18 through 22 for the following valve positions:  
80%, 60%, 50%, 40%, 30%, 20%, 16%.

**TABLE 4-2: Combustion Calibration Readings**

Valve Position	Oxygen (O <sub>2</sub> ) %		Nitrogen Oxide (NOx)	Carbon Monoxide (CO)	Flame $\mu$ A
	INN600, INN800, INN1060	INN1400			
100%	6.0% $\pm$ 0.3%	3.5% $\pm$ 0.2%	<20 ppm	<100 ppm	> 6
80%	5.4% $\pm$ 0.3%	4.5% $\pm$ 0.2%	<20 ppm	<100 ppm	> 6
60%	5.4% $\pm$ 0.3%	5.5% $\pm$ 0.2%	<20 ppm	<100 ppm	> 6
50%	7.0% $\pm$ 0.3%	6.0% $\pm$ 0.2%	<20 ppm	<100 ppm	> 6
40%	7.0% $\pm$ 0.3%	6.5% $\pm$ 0.2%	<20 ppm	<100 ppm	> 6
30%	7.0% $\pm$ 0.3%	6.0% $\pm$ 0.2%	<20 ppm	<100 ppm	> 5
20%	6.5% $\pm$ 0.3%	6.0% $\pm$ 0.2%	<20 ppm	<100 ppm	> 4
16%	6.0% $\pm$ 0.3%	5.5% $\pm$ 0.2%	<20 ppm	<100 ppm	> 2

24. If the oxygen level at the 16% valve position is too high and the Blower voltage is at the minimum value, you can adjust the TAC valve (see Figure 4-6), which is recessed in the top of the Air/Fuel Valve. Rotate the screw **1/2 turn clockwise** to add fuel and **reduce** O<sub>2</sub> to the specified level. Recalibration **MUST** be performed again **from 60% down to 16%** after making a change to the idle screw (TAC valve).



**Figure 4-6. TAC Valve (Idle Screw) Adjustment**

**This completes the NATURAL GAS combustion calibration procedure.**

## 4.4 PROPANE COMBUSTION CALIBRATION

### IMPORTANT!

The unit is shipped from the factory set up for either Natural Gas or Propane, as specified by the Style Number on the Sales Order. **Complete the instructions below only on units running on PROPANE gas.**

Innovation Water Heaters are combustion calibrated at the factory prior to shipping. However, recalibration as part of initial start-up is necessary due to changes in the local altitude, gas BTU content, gas supply piping and supply regulators. Start-Up & Registration Test Data sheets are shipped with each unit. These sheets must be filled out and returned to AERCO for proper Warranty Validation.

It is important to perform the calibration procedure as outlined below, as this will provide optimum performance and keep readjustments to a minimum.

### PROPANE Combustion Calibration Instructions

1. Open the water supply and return valves to the unit and ensure that the system pumps are running.
2. Open the **PROPANE** gas supply valve(s) to the unit.
3. Set the control panel ON/OFF switch to the **OFF** position.
4. Turn on external AC power to the unit.
5. Enter the password **6817** to continue.
6. Set the unit to the MANUAL mode by pressing the **AUTO/MAN** key. A flashing **MANUAL VALVE POSITION** message will be displayed with the present position in %. Also, the **MANUAL** LED will light.
7. Adjust the air/fuel valve position to **0%** by pressing the **▼** arrow key.
8. Ensure that the leak detection ball valve downstream of the SSOV is open.
9. Set the ON/OFF switch to the **ON** position.
10. Change the valve position to **28%** using the **▲** arrow key. The unit should begin its start sequence and fire.
11. Using the **▲** arrow key, increase the valve open position to **100%** and then allow the valve position to reach 100%.
12. With the valve position at 100%, insert the combustion analyzer probe into the 1/8" (3.18 mm) port at the rear of the exhaust manifold. Allow enough time for the combustion analyzer to settle.
13. Check the gas pressure downstream of the SSOV. The pressure is factory set for full rated input, and then recorded in the Max Fire Pressure column on the Manifold Gas Pressure Setting Tag hanging near the SSOV. If the gas pressure **is not** within  $\pm 0.2$ " W.C. of the **last** recorded on the Tag, you must complete Step 14 and 15, below, to adjust the gas pressure. The pressure should be within the range in Table 4-3.

**TABLE 4-3: PROPANE Pressure Range Downstream of SSOV**

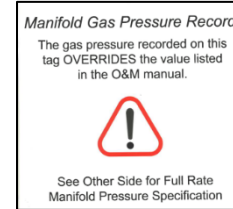
Innovation 600	1.5" – 2.5" W.C. (374 – 623 Pa)
Innovation 800	1.5" – 2.5" W.C. (374 – 623 Pa)
Innovation 1060	1.1" – 2.1" W.C. (274 – 523 Pa)
Innovation 1400	1.6" – 2.8" W.C. (399 – 697 Pa)

**PROPANE Combustion Calibration Instructions**

Unit SN: \_\_\_\_ - \_\_\_\_ - \_\_\_\_

*Only Record a new gas pressure setting if  $\pm 0.2$ "wc different than last value recorded*

Date	Max Fire Pressure ("wc)	High Gas Switch Set ("wc)	O <sub>2</sub> %	Tech Name & Company
				Factory Calibration
				(Field Start-up)



(Back of Tag)

**Figure 4-7. Manifold Gas Pressure Setting Tag (Front and Back)**

- If the gas pressure downstream of the SSOV is **not** within  $\pm 0.2$ " W.C. of the pressure listed on the Manifold Gas Pressure Setting tag, remove the brass hex nut on the SSOV actuator to access the gas pressure adjustment screw. Slowly rotate the screw in approximately 1/4-turn increments **clockwise** to **increase** the gas pressure, **counter-clockwise** to the **reduce** gas pressure, as needed, to reach the value on the tag. Do not allow the pressure to fall outside the range in Table 4-3.



BRASS HEX HEAD CAP

(Remove to access side gas pressure adjustment screw)

**Figure 4-8. SSOV Gas Pressure Adjustment Screw Location**

- If it was removed in the previous step, replace the brass hex cap on the SSOV.
- Press the **MENU** key on the front panel of the C-More until **COMBUSTION CAL MENU** appears on the display.
- Navigate to the **SET Stdby V Out (Standby Voltage)** setting and verify that it is set to **2.0 V**. AERCO recommends that it be kept at 2.0 volts to prevent flue gas recirculation.
- Press the **▲** arrow key until **Set Valve Position** reads **100%**, then press the **ENTER** key.
- Press the **CHANGE** key and observe that **CAL VOLTAGE 100%** is flashing.
- The oxygen level at the 100% valve position should match the value in Table 4-4, below. You may need increase the O<sub>2</sub>% above this range to avoid combustion tone issues. Also ensure that the nitrogen oxide (NO<sub>x</sub>), carbon monoxide (CO) and flame strength readings match the values shown in Table 4-4.
- If the oxygen level is not within the specified range, adjust the level using the **▲** and **▼** arrow keys. This will adjust the output voltage to the blower motor as indicated on the display. Press the **▲** arrow key to **increase** the oxygen level or press the down **▼** arrow key to **decrease** the oxygen level.
- Once the oxygen level is within the specified range at 100%, press the **ENTER** key to store the selected blower output voltage for the 100% valve position. Record all readings on the Combustion Calibration Sheets provided.

**PROPANE Combustion Calibration Instructions**

23. Repeat steps 18 through 22 for the following valve positions:  
80%, 60%, 50%, 40%, 30%, 20%, 18%.

**TABLE 4-4: Combustion Calibration Readings**

Valve Position	Oxygen (O <sub>2</sub> ) %		Nitrogen Oxide (NO <sub>x</sub> )	Carbon Monoxide (CO)	Flame $\mu$ A
	INN600, INN800, INN1060	INN1400			
100%	4.0% $\pm$ 0.3%	3.5% $\pm$ 0.2%	<20 ppm	<150 ppm	> 6
80%	4.5% $\pm$ 0.3%	4.5% $\pm$ 0.2%	<20 ppm	<150 ppm	> 6
60%	4.5% $\pm$ 0.3%	5.5% $\pm$ 0.2%	<20 ppm	<150 ppm	> 6
50%	5.5% $\pm$ 0.3%	6.0% $\pm$ 0.2%	<20 ppm	<150 ppm	> 6
40%	6.5% $\pm$ 0.3%	6.5% $\pm$ 0.2%	<20 ppm	<150 ppm	> 6
30%	7.0% $\pm$ 0.3%	6.0% $\pm$ 0.2%	<20 ppm	<150 ppm	> 5
20%	6.5% $\pm$ 0.3%	6.0% $\pm$ 0.2%	<20 ppm	<150 ppm	> 4
16%	6.5% $\pm$ 0.3%	5.5% $\pm$ 0.2%	<20 ppm	<150 ppm	> 3

24. If the oxygen level at the 16% valve position is too high and the Blower voltage is at the minimum value, you can adjust the TAC valve (see Figure 4-6, above), which is recessed in the top of the Air/Fuel Valve. Rotate the screw 1/2 turn clockwise (CW) to add fuel and reduce the O<sub>2</sub> to the specified level. Recalibration **MUST** be performed again from **60% down to 18%** after making a change to the idle screw (TAC valve).

**This completes the PROPANE gas combustion calibration procedure.**

**4.5 REASSEMBLY**

Once the combustion calibration adjustments are properly set, the unit can be reassembled for service operation.

**Reassembly**

1. Set the ON/OFF switch in the **OFF** position.
2. Disconnect AC power from the unit.
3. Shut off the gas supply to the unit.
4. Remove the manometer and barbed fittings and reinstall the NPT plug using a suitable pipe thread compound.
5. Remove the combustion analyzer probe from the 1/8" (3.18 mm) vent hole in the exhaust manifold. Replace the 1/8" NPT plug in the manifold.
6. Replace the unit's side panels and front door.

### 4.6 TEMPERATURE CONTROL CALIBRATION

Carefully follow the procedures below to properly set up the temperature control for the heater. Ignoring this commissioning step may cause water temperature faults, poor water temperature control, and rapid cycling of the heater.

The unit normally comes factory set and calibrated for a 130°F (54.4°C) setpoint (default value). However, if a different setpoint temperature is desired, it can be changed using the procedure in Section 4.6.1. If the setpoint is changed, it must be done prior to temperature control calibration.

There are two primary adjustments for performing temperature calibration: Min Load Adj and Max Load Adj (minimum and maximum load adjustment). Adjustments to these settings are made at minimum and maximum load conditions and should be made in small increments, from 1 to 3 degrees F (0.55 to 1.65 degrees C). After making an adjustment, the outlet water temperature must be allowed to settle for several minutes prior to making any further adjustments.

When calibrating temperature control, observe the following:

#### Temperature Control Calibration

1. The unit must be in the Auto mode of operation.
2. The Outlet Feedback option in the Tuning Menu must be set to **DISABLED** while performing calibration.
3. Monitor the OUTLET TEMPERATURE display and VALVE POSITION bar-graph to set load conditions and observe the effect of adjustments.
4. Perform the calibration using the Tuning Menu of the C-More Controller.
5. Make small adjustments and allow time between adjustments for the outlet water temperature to stabilize.
6. Maintain water flow as constant as possible during these adjustments.
7. Ensure that recirculation loops are operational while the calibration is being performed.
8. Upon completion of calibration, set the Outlet Feedback back to **ENABLE**.

Temperature control calibration is accomplished by performing the Minimum and Maximum Load Adjustment procedures in Sections 4.6.2 and 4.6.3, respectively.

#### 4.6.1 Setting the Outlet Water Temperature Setpoint

The setpoint temperature of the unit may be changed using the following steps. However, once a setpoint has been changed, recalibration may be necessary. The temperature calibration procedures are provided in Sections 4.6.2 and 4.6.3.

To adjust the unit's setpoint, proceed as follows:

#### Setting Outlet Water Temperature Setpoint

1. Press the **MENU** key until **CONFIGURATION MENU** is displayed.
2. Press the **▲** or **▼** arrow key until Internal Setpt is displayed along with the present setpoint temperature.
3. To change the setpoint, press the **CHANGE** key. The display will begin to flash.
4. Press the **▲** or **▼** arrow key until the desired setpoint is displayed.
5. Press the **ENTER** key to save the change.

### 4.6.2 Minimum Load Adjustment

With the unit in operation, check the temperature control at minimum load as described below.

#### Minimum Load Adjustment

1. While monitoring the VALVE POSITION bar-graph, create a minimum load on the system that will yield a steady valve position between 25% and 35%.

**NOTE:**

It may be desirable to shut off the outlet valve and use the hose bib (see Figure 2-4) to simulate a minimum flow load condition.

2. Wait several minutes to allow the outlet temperature to stabilize under load conditions.
3. Once stabilized, the OUTLET TEMPERATURE display should read no more than 2 to 3 degrees F (1.1 to 1.65 degrees C) above the unit's setpoint.
4. If the outlet temperature is stabilized, proceed to the Maximum Load Adjustment procedure in Section 4.6.3. If the temperature is not stabilized, proceed to step 5.
5. Press the **MENU** key and select the **Tuning Menu**.
6. Press the **▲** or **▼** arrow key until **MIN LOAD ADJ** is displayed.
7. Press the **CHANGE** key. The display will begin to flash.
8. Raise or lower the minimum load adjustment in increments of one or two using the **▲** or **▼** arrow key. Increasing this value will increase outlet water temperature, while decreasing it will decrease outlet water temperature.
9. Press **ENTER** to save the change. Allow time for the system to stabilize between adjustments
10. Repeat steps 5 through 9 as needed until the temperature is stabilized at no more than 2 to 3 degrees F (1.1 to 1.65 degrees C) above the unit's setpoint.

### 4.6.3 Maximum Load Adjustment

Check the temperature control at maximum load as follows:

#### Maximum Load Adjustment

1. While monitoring the VALVE POSITION bar-graph, create a maximum load on the system that will yield a steady valve position between 80% and 90%.

**NOTE:**

It may be necessary to open the outlet valve if it was closed during minimum load adjustment to obtain a sufficient flow rate for maximum adjustment.

2. Wait several minutes to allow the outlet water temperature to stabilize under load conditions.
3. Once stabilized, the OUTLET TEMPERATURE display should read no more than 2 to 3 degrees F (1.1 to 1.65 degrees C) below the unit's setpoint.
4. If the outlet temperature is stabilized, no adjustment is necessary. If the temperature is not stabilized, proceed to step 5.
5. Press the **MENU** key and select the **Tuning Menu**.
6. Press the **▲** or **▼** arrow key until **MAX LOAD ADJ** is displayed.



### Maximum Load Adjustment

7. Press the **CHANGE** key. The display will begin to flash.
8. Raise or lower the maximum load adjustment using the ▲ or ▼ arrow key. Increasing this value will increase outlet water temperature, while decreasing it will decrease water temperature.
9. Press **ENTER** to save the change. Allow time for the system to stabilize between adjustments.
10. Repeat steps 5 through 9 as needed until the temperature is stabilized 2 to 3 degrees F (1.1 to 1.65 degrees C) below the unit's setpoint.
11. If the outlet temperature does not maintain setpoint after a reasonable amount of time and adjustment, contact your local AERCO representative.

**NOTE:**

After performing Temperature Calibration and prior to placing the water heater into service, be sure to set the *Outlet Feedback* option in the *Tuning Menu* back to ON.

## 4.7 OVER-TEMPERATURE LIMIT SWITCHES

The unit contains both **Automatic Reset** and **Manual Reset Over-Temperature Limit** switches, shown in Figure 4-9. They can be accessed by opening the front panel door of the unit.

The **Manual Reset Over-Temperature Limit** switch is not adjustable and is permanently fixed at 190°F (87.7°C). This switch will shut down and lock out the heater if the water temperature exceeds 190°F (87.7°C). Following an over-temperature condition, it must be manually reset by pressing the **RESET** button before the heater can be restarted.

The **Automatic Reset Over-Temperature Limit** switch is adjustable and allows the unit to restart, once the temperature drops below its temperature setting. Set the **Automatic Reset Over-Temperature Limit** switch to the desired setting.



**Figure 4-9. Over-Temperature Limit Switch Location**



## CHAPTER 5. SAFETY DEVICE TESTING

### 5.1 INTRODUCTION

Periodic safety device testing is required to ensure that the control system and safety devices are operating properly. The heater control system comprehensively monitors all combustion-related safety devices before, during and after the start sequence. The following tests check to ensure that the system is operating as designed.

Operating controls and safety devices should be tested on a regular basis or following service or replacement. All testing must conform to local codes.

#### NOTES:

MANUAL and AUTO modes of operation are required to perform the following tests. For a complete explanation of these modes, see Chapter 3.

It will also be necessary to remove the front door and side panels from the unit to perform the following tests.

#### WARNING!

**ELECTRICAL CURRENT OF 220, 110 AND 24 VOLTS AC MAY BE USED IN THIS EQUIPMENT. POWER MUST BE REMOVED PRIOR TO PERFORMING WIRE REMOVAL OR OTHER TEST PROCEDURES THAT CAN RESULT IN ELECTRICAL SHOCK.**

### 5.2 LOW GAS PRESSURE FAULT TEST

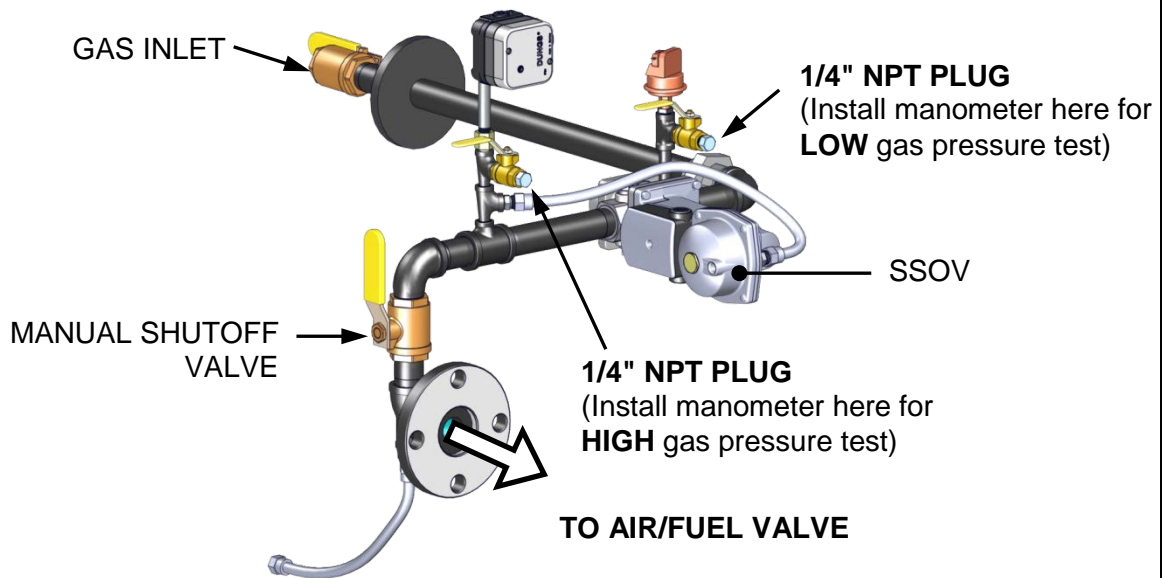
To simulate a low gas pressure fault, refer to Figure 5-1 and proceed as follows:

#### Low Gas Pressure Fault Test Instructions

1. Refer to Figure 5-1 and ensure that the leak detection ball valve located at the **Low Gas Pressure** switch is closed.
2. Remove the 1/4" plug from the ball valve at the **Low Gas Pressure** switch shown in the lower portion of Figure 5-1.
3. Install a **0 – 16" W.C. (0 – 4.0 kPa)** manometer (or a W.C. gauge) where the 1/4" plug was removed.
4. Slowly open the ball valve near the **Low Gas Pressure** switch.
5. Place the unit in Manual mode and adjust the air/fuel valve position (% open) between 25 and 30%.
6. While the unit is firing, slowly close the external manual gas shut-off valve.
7. The unit should shut down and display a **LOW GAS PRESSURE** fault message at approximately 2.6" W.C. (648 Pa). The **FAULT** indicator should also start flashing.
8. Fully open the external manual gas shut-off valve and press the **CLEAR** button on the C-More Controller.
9. The fault message should clear and the **FAULT** indicator should go off. The unit should restart.

**Low Gas Pressure Fault Test Instructions**

10. Upon test completion, close the ball valve and remove the manometer. Replace the 1/4" plug removed in step 2.



**Figure 5-1. Low & High Gas Pressure Testing (INN600–1060 Gas Train Shown)**

**5.3 HIGH GAS PRESSURE FAULT TEST**

To simulate a high gas pressure fault, refer to Figure 5-1 and proceed as follows:

**High Gas Pressure Fault Instructions**

1. Remove the 1/4" plug from the leak detection ball valve shown in Figure 5-1.
2. Install a **0 – 16" W.C. (0 – 4.0 kPa)** manometer (or W.C. gauge) where the 1/4" plug was removed.
3. Slowly open the leak detection ball valve
4. Start the unit in Manual mode at a valve position (firing rate) of 25%.
5. Slowly increase the gas pressure using the adjustment screw on the SSOV.
6. The unit should shut down and display a **HIGH GAS PRESSURE** fault message when the gas pressure exceeds the setting on the high gas pressure switch. The **FAULT** indicator should also start flashing. The switch should be set for 1" W.C. more than the "Manifold Pressure Setpoint" written on the Manifold Gas Pressure Setting tag. For example: if the tag states that the unit was set up at 3.0" W.C. full input rate as the factory calibration, then the high gas pressure switch will be set for 4.0" W.C. (1.0 kPa).
7. Reduce the gas pressure back to the original setting listed on the tag.
8. Press the **CLEAR** button on the C-More Controller to clear the fault.
9. The fault message should clear and the **FAULT** indicator should go off. The unit should restart.
10. Upon test completion, close the ball valve and remove the manometer. Replace the 1/4" plug removed in step 1.

### 5.4 LOW WATER LEVEL FAULT TEST

To simulate a low water level fault:

#### Low Water Level Fault Test Instructions

1. Set the ON/OFF switch to the **OFF** position
2. Close the water shut-off valves in the supply and return piping to the unit.
3. Slowly open the drain valve on the rear of the unit. If necessary the unit's relief valve may be opened to aid in draining.
4. Continue draining the unit until a **LOW WATER LEVEL** fault message is displayed and the **FAULT** indicator flashes.
5. Place the unit in the Manual mode and raise the valve position above 30%.
6. Set the ON/OFF switch to the **ON** position. The **READY** light should remain off and the unit should not start. If the unit does start, shut the unit off immediately and refer fault to qualified service personnel.
7. Close the drain and pressure relief valve used in draining the unit.
8. Open the water shut-off valve in the return piping to the unit.
9. Open the water supply shut-off valve to the unit to refill.
10. After the shell is full, press the **LOW WATER LEVEL RESET** button to reset the low water cutoff.
11. Press the **CLEAR** button to reset the **FAULT** LED and clear the displayed error message.
12. Set the ON/OFF switch to the **ON** position. The unit is now ready for operation.

### 5.5 WATER TEMPERATURE FAULT TEST

A high water temperature fault is simulated by adjusting the **Automatic Reset Over-Temperature Limit** switch. This switch is accessible from the front of the unit as shown in Figure 5-2.

#### Water Temperature Fault Test Instructions

1. Start the unit in the normal operating mode. Allow the unit to stabilize at its setpoint.
2. Lower the adjustable **Automatic Reset Over-Temperature Limit** switch setting to match the displayed **OUTLET TEMPERATURE**.
3. Once the **Automatic Reset Over-Temperature Limit** switch setting is approximately at, or just below, the actual outlet water temperature, the unit should shut down. The **FAULT** indicator should start flashing and a **HIGH WATER TEMP SWITCH OPEN** fault message should be displayed. It should not be possible to restart the unit.
4. Reset the adjustable over-temperature switch to its original setting.
5. The unit should start once the **Automatic Reset Over-Temperature Limit** switch setting is above the actual outlet water temperature.

#### NOTE:

The (non-adjustable) **Manual Reset Over-Temperature Limit** switch is calibrated to trip if the discharge water exceeds 190° F (87.8° C). Testing of this device must be done by authorized personnel only.



**Figure 5-2. Over-Temperature Limit Switch Setting**

## 5.6 INTERLOCK TESTS

The unit is equipped with two interlock circuits called the Remote Interlock and Delayed Interlock. Terminal connections for these circuits are located in the I/O Box (Figure 2-13) and are labeled REMOTE INTL'K IN and DELAYED INTL'K IN. These circuits can shut down the unit in the event that an interlock is opened. These interlocks are shipped from the factory jumpered (closed). However, each of these interlocks may be utilized in the field as a remote stop and start, an emergency cut-off, or to prove that a device such as a pump, gas booster, or louver is operational.

### 5.6.1 Remote Interlock

#### Remote Interlock Instructions

1. Remove the cover from the I/O Box and locate the REMOTE INTL'K IN terminals (see Figure 2-13).
2. Start the unit in the Manual mode and set the valve position between 25% and 30%.
3. If there is a jumper across the REMOTE INTL'K IN terminals, remove one side of the jumper. If the interlock is being controlled by an external device, either open the interlock via the external device or disconnect one of the wires leading to the external device.
4. The unit should shut down and display **INTERLOCK OPEN**.
5. Once the interlock connection is reconnected, the **INTERLOCK OPEN** message should automatically clear and the unit should restart.

### 5.6.2 Delayed Interlock

#### Delayed Interlock Instructions

1. Remove the cover from the I/O Box and locate the DELAYED INTL'K IN terminals (see Figure 2-13).
2. Start the unit in the Manual mode at a valve position between 25% and 30%.
3. If there is a jumper across the DELAYED INTL'K IN terminals, remove one side of the jumper. If the interlock is connected to a proving switch of an external device, disconnect one of the wires leading to the proving switch.
4. The unit should shut down and display a **DELAYED INTERLOCK OPEN** fault message. The **FAULT** LED should be flashing.
5. Reconnect the wire or jumper removed in step 3 to restore the interlock.
6. Press the **CLEAR** button to reset the fault.
7. The unit should start.

### 5.7 FLAME FAULT TESTS

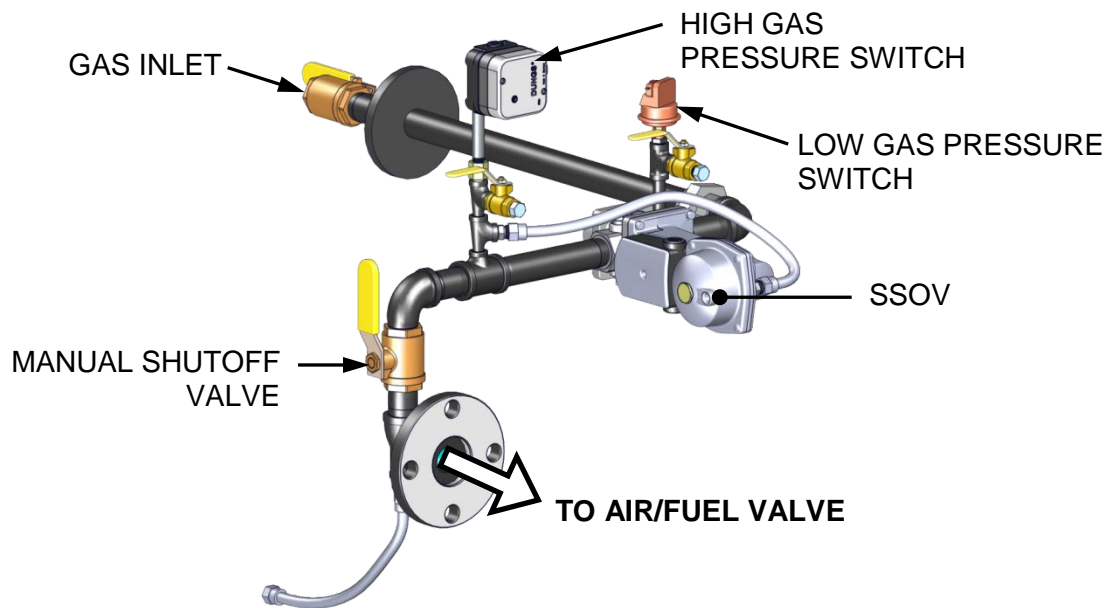
Flame faults can occur during ignition or while the unit is already running. To simulate each of these fault conditions, proceed as follows:

#### Flame Fault Tests Instructions

1. Set the ON/OFF switch to the **OFF** position.
2. Place the unit in the Manual mode and set the valve position between 25% and 30%.
3. Close the manual gas shutoff valve located between the Safety Shut-Off Valve (SSOV) and the Air/Fuel Valve (see Figure 5-3).
4. Set the ON/OFF switch to the **ON** position to start the unit.
5. The unit should shut down after reaching the Ignition cycle and display **FLAME LOSS DURING IGN.**
6. Open the valve closed in step 3 and press the **CLEAR** button.
7. Restart the unit and allow it to prove flame.
8. Once flame is proven, close the 1" manual gas shut-off valve located between the SSOV (Figure 5-3) and the Air/Fuel Valve.
9. The unit should shut down and execute an IGNITION RETRY cycle by performing the following:
  - a) The unit will execute a shutdown purge cycle for a period of 15 seconds and display **WAIT FAULT PURGE.**
  - b) The unit will execute a 30 second re-ignition delay and display **WAIT RETRY PAUSE.**
  - c) The unit will then execute a standard ignition sequence and display **WAIT IGNITION RETRY.**
10. Since the manual gas shutoff valve is still closed, the unit will shut down and display **FLAME LOSS DURING IGNITION** following the IGNITION RETRY cycle.
11. Open the valve closed in step 8.

**Flame Fault Tests Instructions**

12. Press the **CLEAR** button. The unit should restart and fire.



**Figure 5-3. Manual Gas Shut-Off Valve Location (INN600-1060 Gas Train Shown)**

**5.8 AIR FLOW FAULT TESTS**

These tests check the operation of the **Blower Proof** switch and **Blocked Inlet** switch shown in Figure 5-4.

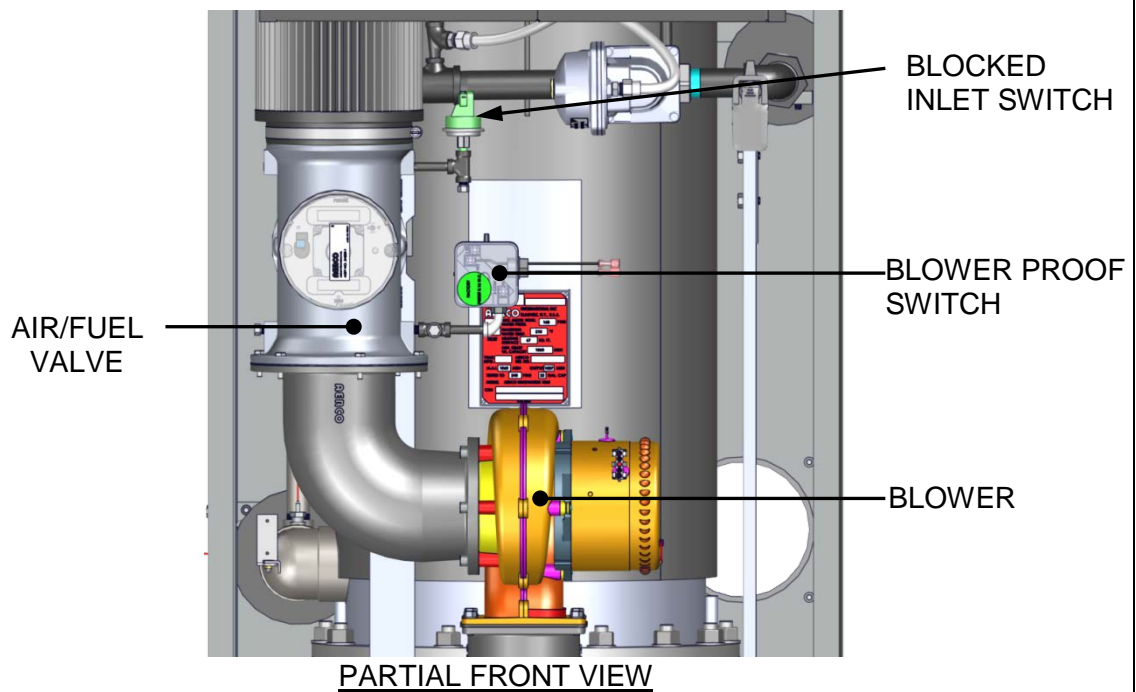
**Air Flow Fault Tests Instructions**

1. Disable the blower output drive voltage as follows:
  - (a) Press the **MENU** key until **CONFIGURATION MENU** is displayed.
  - (b) Press the **▲** arrow key until the **ANALOG OUTPUT** function is displayed, then press the **CHANGE** key.
  - (c) Press the **▼** arrow key until **OFF** is displayed, then press the **ENTER** key.
2. Start the unit in the Manual mode at a valve position of 25%.
3. The unit should shut down and execute an **IGNITION RETRY** cycle by performing the following steps:
  - (a) The unit will execute a 30 second re-ignition delay and display **WAIT RETRY PAUSE**.
  - (b) The unit will then execute a standard ignition sequence and display **WAIT IGNITION RETRY**.
4. The unit should perform two **IGNITION RETRY** cycles and then shut down on the third successive ignition attempt. The unit will display **AIRFLOW FAULT DURING PURGE**.



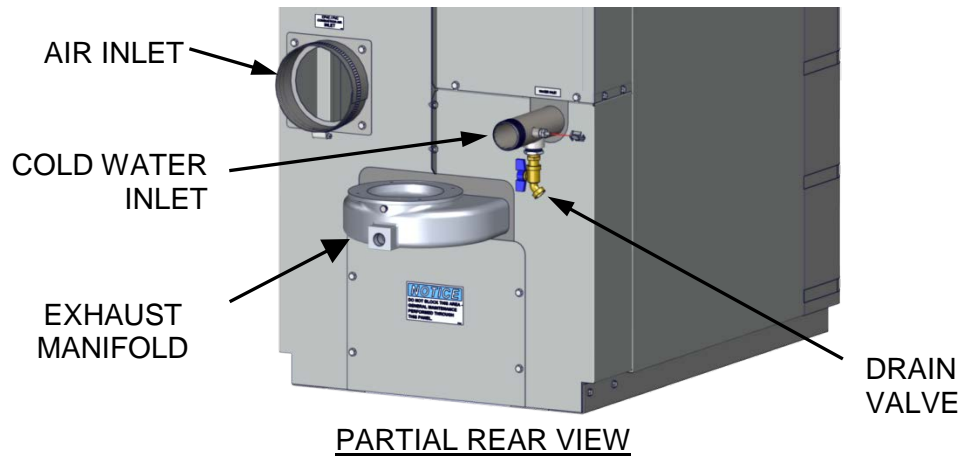
### Air Flow Fault Tests Instructions

5. Re-enable the blower output drive voltage by performing the following steps:
  - (a) Press the **MENU** key until **CONFIGURATION MENU** is displayed.
  - (b) Press the **▲** arrow key until the **ANALOG OUTPUT** function is displayed, then press the **CHANGE** key.
  - (c) Press the **▲** arrow key until **VALVE POSITION 0-10V** is displayed, then press the **ENTER** key.
6. Once the unit has proved flame, turn off the blower by going to the Configuration Menu, Analog Output menu item and select **OFF**.
7. The **Blower Proof** switch will open and the blower should stop. The unit should shut down and display **AIRFLOW FAULT DURING RUN**.
8. Go to the Configuration Menu, Analog Output item and select **VALVE POSITION 0-10V**.
9. Press the **CLEAR** button. The unit should restart.
10. Next, check the operation of the **Blocked Inlet** switch located on the inlet side of the Air/Fuel Valve (Figure 5-4).
11. Ensure that the sheet metal panels are securely installed on the water heater and the unit is running.
12. At the rear of the unit, partially block the air inlet (Figure 5-5) with a plywood sheet or metal plate.
13. The unit should shut down and again display **AIRFLOW FAULT DURING RUN**.
14. Unblock the air inlet and press the **CLEAR** button. The unit should restart.



**Figure 5-4. Blower Proof & Blocked Inlet Switch Locations**

**Air Flow Fault Tests Instructions**



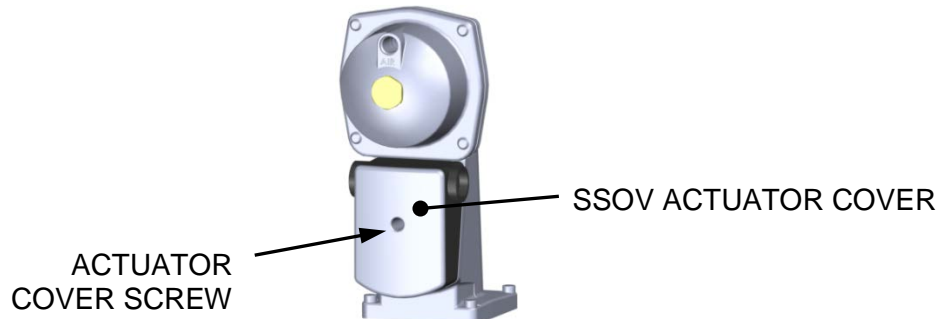
**Figure 5-5. Water Heater Rear View Showing Air Inlet Location**

**5.9 SSOV PROOF OF CLOSURE SWITCH**

The SSOV shown in Figure 5-1 contains the **Proof Of Closure** switch. The **Proof Of Closure** switch circuit is checked as follows:

**SSOV Proof of Closure Switch Instructions**

1. Set the unit's ON/OFF switch to the **OFF** position.
2. Place the unit in Manual mode and set the valve position between 25% and 30%
3. Refer to Figure 5-1 and locate the SSOV.
4. Remove the cover from the SSOV by loosening the screw shown in Figure 5-6. Lift off the cover to access the terminal wiring connections.
5. Disconnect wire #148 from the SSOV to "open" the **Proof Of Closure** switch circuit.
6. The unit should fault and display **SSOV SWITCH OPEN**.
7. Replace wire #148 and press the **CLEAR** button.
8. Set the ON/OFF switch to **ON** to start the unit.
9. Remove the wire again when the unit reaches the purge cycle and **PURGING** is displayed.
10. The unit should shut down and display **SSOV FAULT DURING PURGE**.
11. Replace the wire on the SSOV and press the **CLEAR** button. The unit should restart.



**Figure 5-6. SSOV Actuator Cover Location**



### 5.10 PURGE SWITCH OPEN DURING PURGE

The **Purge** switch (and **Ignition** switch) is located on the Air/Fuel Valve. To check the switch, proceed as follows:

#### Purge Switch Open During Purge Instructions

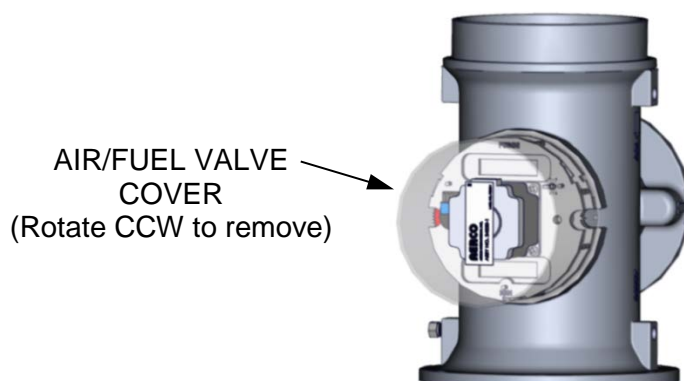
1. Set the unit's ON/OFF switch to the **OFF** position. Place the unit in Manual mode and set the valve position between 25% and 30%.
2. Remove the Air/Fuel Valve cover by rotating the cover counterclockwise to unlock it (see Figure 5-7).
3. Remove one of the two wires (#171 or #172) from the **Purge** switch (Figure 5-8).
4. Initiate a unit start sequence.
5. The unit should begin its start sequence, then shut down and display **PRG SWITCH OPEN DURING PURGE**.
6. Replace the wire on the **Purge** switch and depress the **CLEAR** button. The unit should restart.

### 5.11 IGNITION SWITCH OPEN DURING IGNITION

The **Ignition** switch (and the **Purge** switch) is located on the Air/Fuel Valve. To check the switch, proceed as follows:

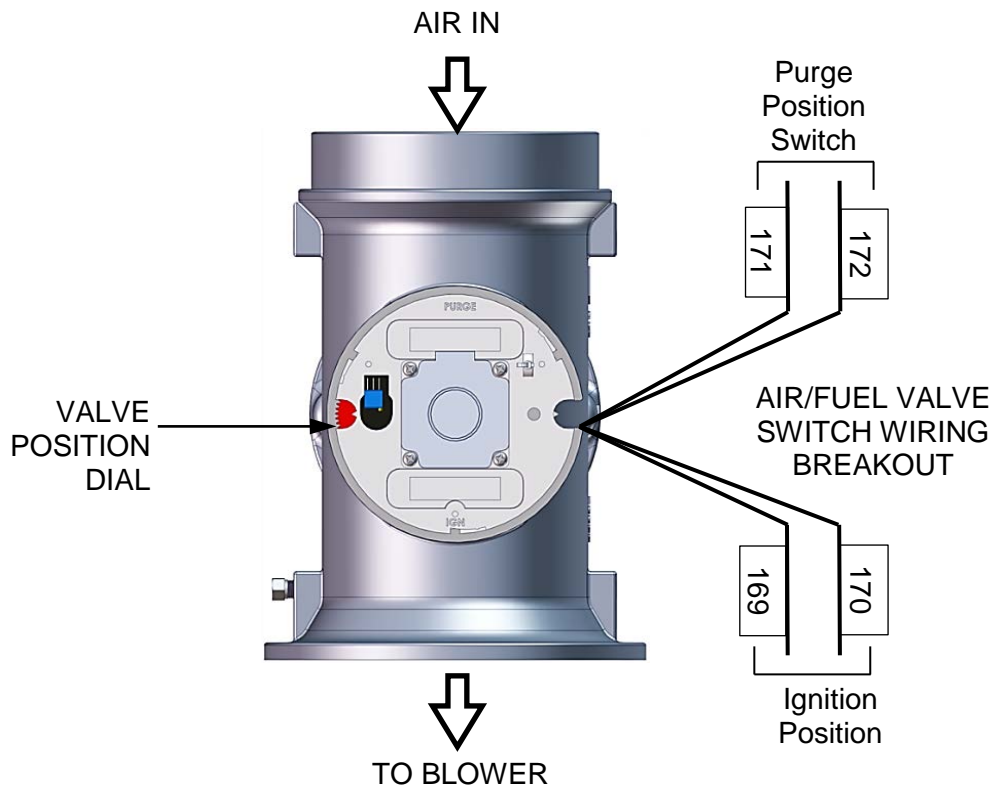
#### Ignition Switch Open During Ignition Instructions

1. Set the unit's ON/OFF switch to the **OFF** position.
2. Place the unit in Manual mode and set the valve position between 25% and 30%.
3. Remove the Air/Fuel Valve cover (see Figure 5-7) by rotating the cover counterclockwise to unlock and lift up to remove.
4. Remove one of the two wires (#169 or #170) from the **Ignition** switch (Figure 5-8).
5. Initiate a unit start sequence.
6. The unit should begin its start sequence and then shut down and display **IGN SWITCH OPEN DURING IGNITION**.
7. Replace the wire on the **Ignition** switch and press the **CLEAR** button. The unit should restart.



**Figure 5-7. Typical Air/Fuel Valve Cover Location**

**Ignition Switch Open During Ignition Instructions**



**Figure 5-8. Air/Fuel Valve Purge and Ignition Switch Locations**

**5.12 SAFETY PRESSURE RELIEF VALVE TEST**

Test the safety Pressure Relief Valve in accordance with ASME Pressure Vessel Code, Section VI.

## CHAPTER 6. MAINTENANCE

### 6.1 MAINTENANCE SCHEDULE

The Innovation Water Heater requires regular routine maintenance to ensure continued reliable operation throughout the service life of the unit. For optimum operation, AERCO requires that the following routine maintenance procedures be performed in the time periods specified in Table 6-1.

Appendix I contains a list of the recommended spare parts for maintenance of the Innovation Heater.

**WARNING!**

TO AVOID PERSONAL INJURY, PRIOR TO SERVICING ENSURE THAT THE FOLLOWING GUIDELINES ARE STRICTLY OBSERVED:

- DISCONNECT THE AC SUPPLY BY TURNING OFF THE SERVICE SWITCH AND AC SUPPLY CIRCUIT BREAKER.
- SHUT OFF THE GAS SUPPLY AT THE MANUAL SHUT-OFF VALVE PROVIDED WITH THE UNIT
- ALLOW THE UNIT TO COOL TO A SAFE WATER TEMPERATURE TO PREVENT BURNING OR SCALDING

**Table 6-1 - Maintenance Schedule**

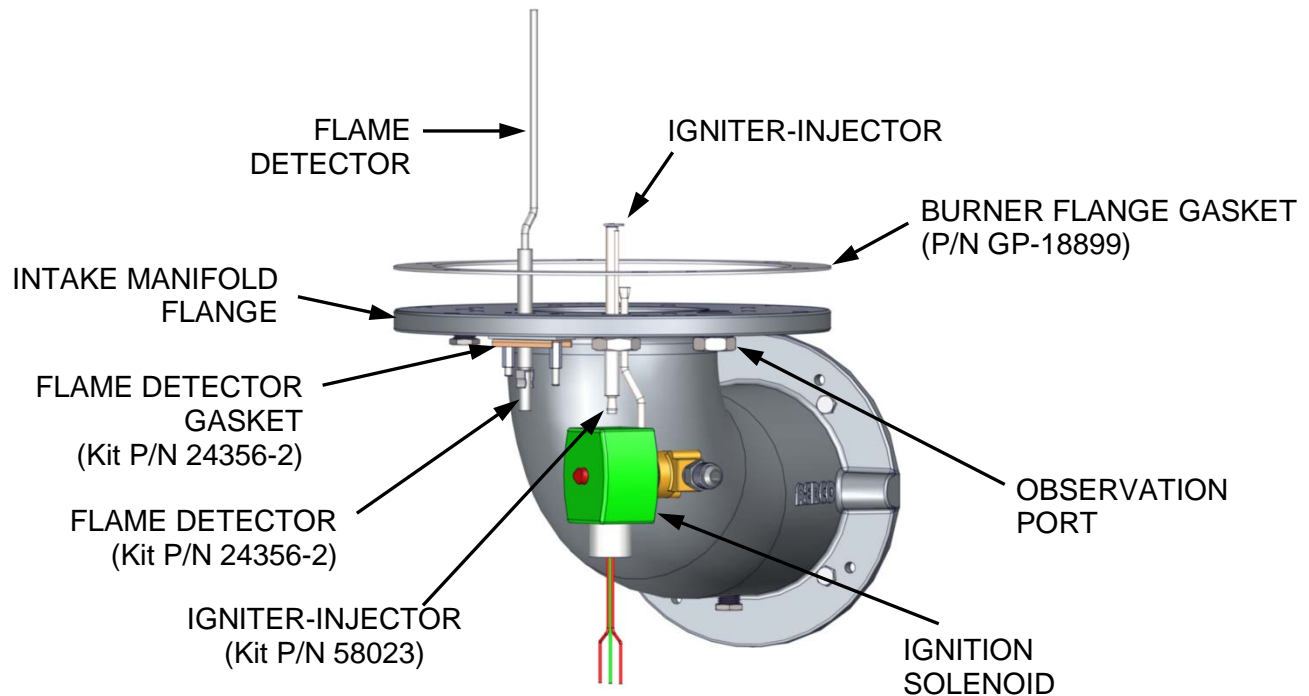
Section	Item	6 Mos.	12 Mos.	24 Mos.	Labor Time
6.2	Igniter-Injector (Kit P/N 58023)	*Inspect	Inspect, replace if necessary	Replace	15 min.
6.3	Flame Detector (Kit P/N 24356-2)	*Inspect	Inspect, replace if necessary	Replace	15 min.
6.4	Combustion Calibration	*Check	Check		1 hr.
6.5	Testing of Safety Devices		Test		20 min.
6.6	Fireside Inspection			Inspect & Clean	3 hrs.
6.7	Waterside Port Inspection	*Inspect	Inspect	Inspect	30 min.
6.8	Waterside Heat Exchanger Inspection		Inspect & Clean (as required)	-	2 hrs.
6.9	Condensate Drain Trap	*Inspect	Inspect & Clean	-	30 min.
6.10	Air Filter (P/N 59138)		Clean or Replace	-	5 min.
6.11	Low Water Cutoff (LWCO) Probe Capacitor (Kit P/N 69126)	-	Test	Replace & Test	15 min.

\* Only performed after initial 6 month period after initial startup.

## 6.2 IGNITER-INJECTOR

The igniter-injector is located on the flange of the intake manifold, at the bottom of the unit's heat exchanger. The igniter-injector (Kit P/N **58023**) is the same for Natural Gas and Propane units. Figure 6-1 shows the intake manifold (removed from the heater) showing the location of the igniter-injector, flame detector and gasket (Kit P/N **24356-2**) and related components.

The igniter-injector may be hot, therefore, care should be exercised to avoid burns. It is easier to remove the igniter-injector from the unit after the unit has cooled to room temperature.



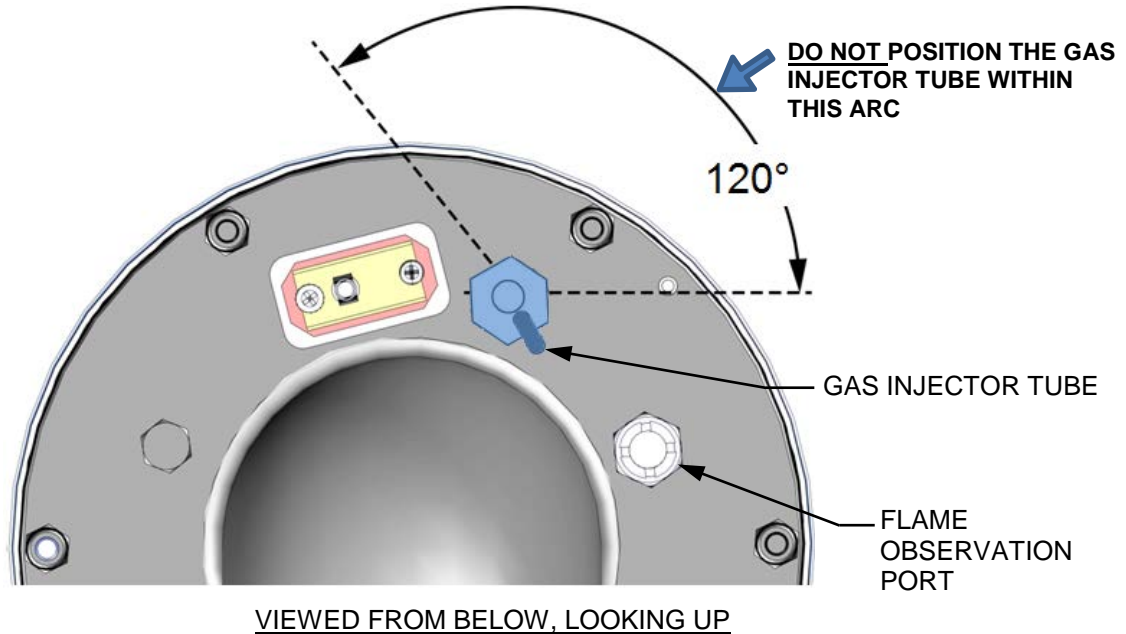
**Figure 6-1. Intake Manifold with Igniter-Injector & Flame Detector**

### Igniter-Injector Inspection/Replacement Instructions

1. Set the ON/OFF switch on the control panel, to the **OFF** position. Disconnect AC power from the unit.
2. Remove the side and rear panels from the unit.
3. Disconnect the ignition cable and ground wire from the igniter-injector.
4. Refer to Figure 6-1. Disconnect the compression nut securing the gas injector tube of the igniter-injector to the elbow of the ignition assembly. Disconnect the ignition assembly from the igniter-injector.
5. Loosen and remove the igniter-injector from the burner plate.
6. Check the igniter-injector for evidence of erosion or carbon build-up. If there is evidence of substantial erosion or carbon build-up, the igniter-injector should be replaced. If carbon build-up is present, clean the component using fine emery cloth. Repeated carbon build-up is an indication that the combustion settings of the unit should be checked. Refer to Chapter 4 for combustion calibration procedures.
7. Prior to reinstalling the igniter-injector, apply a high temperature, conductive, anti-seize compound to the threads.

**Igniter-Injector Inspection/Replacement Instructions**

8. Install the igniter-injector on the intake manifold flange. Use the number of clocking washers required to rotate the Igniter-Injector so that the injector tube is **outside** the approximately 120° arc, as shown in Figure 6-2.



**Figure 6-2. Igniter-Injector & Flame Detector Mounting Details**

9. **Torque the igniter-injector to 15 ft-lbs. Do Not Over Tighten**
10. Connect the ignition assembly to the gas injector tube of the igniter-injector by securing the compression nut to the elbow of the ignition assembly.
11. Reconnect the igniter-injector cable and ground wire.
12. Reinstall the side and rear panels on the unit.

### 6.3 FLAME DETECTOR

Flame detector (Kit P/N **24356-2**) is used on ALL Innovation Water Heater models. The flame detector is also located on the flange of the intake manifold as shown in Figures 6-1 and 6-2. The flame detector may be hot. Allow the unit to cool sufficiently before removing the flame detector.

To inspect or replace the flame detector:

#### Flame Detector Inspection/Replacement Instructions

1. Set the ON/OFF switch on the control panel, to the **OFF** position. Disconnect AC power from the unit.
2. Remove the side and rear panels from the unit.
3. Disconnect the flame detector lead wire.
4. Remove the two (2) hex standoffs securing the flame detector to the intake manifold (Figures 6-1 and 6-2). The flame detector is secured to the burner intake manifold with one (1) #10-32 and one (1) #8-32 hex standoff.
5. Remove the flame detector and gasket from the manifold flange.
6. Thoroughly inspect the flame detector. If eroded, the detector should be replaced. Otherwise, clean the detector with a fine emery cloth.
7. Reinstall the flame detector and flame detector gasket.
8. Reconnect the flame detector lead wire.
9. Reinstall the side and rear panels on the unit.

### 6.4 COMBUSTION CALIBRATION

Combustion settings must be checked at the intervals shown in Table 6-1 as part of the maintenance requirements. Refer to Chapter 4 for combustion calibration instructions.

### 6.5 SAFETY DEVICE TESTING

Systematic and thorough tests of the operating and safety devices should be performed to ensure that they are operating as designed. Also, certain code requirements specify that these tests be performed on a scheduled basis. Test schedules must conform to local jurisdictions. The results of the tests should be recorded in a log book. See Chapter 5 for Safety Device Test Procedures.

## 6.6 FIRESIDE INSPECTION

Fireside inspection of the Innovation Water Heater includes removing the exhaust manifold, intake manifold, and the burner assembly from the unit.

The purpose of this inspection is to check for the formation of deposits on the inside of the heat exchanger tubes, exhaust manifold, and/or the burner assembly. These deposits can be caused by the presence of even trace amounts of chlorides and/or sulfur, in the combustion air and fuel sources. Such deposits can be influenced by the extent of the condensing operation and the chloride and sulfur levels that can vary significantly from application to application.

Since the fireside inspection will include removal of the exhaust manifold, burner assembly and intake manifold from the Innovation Water Heater, the following replacement gaskets will be necessary for reassembly upon completion of the inspection:

Part Number	Quantity	Description
GP-18899	2	Burner Flange Gasket
81048	1	Flame Detector Gasket
81198	1	Intake Manifold Flange Gasket
GP-122537	1	Manifold-To-Heat Exchanger Gasket

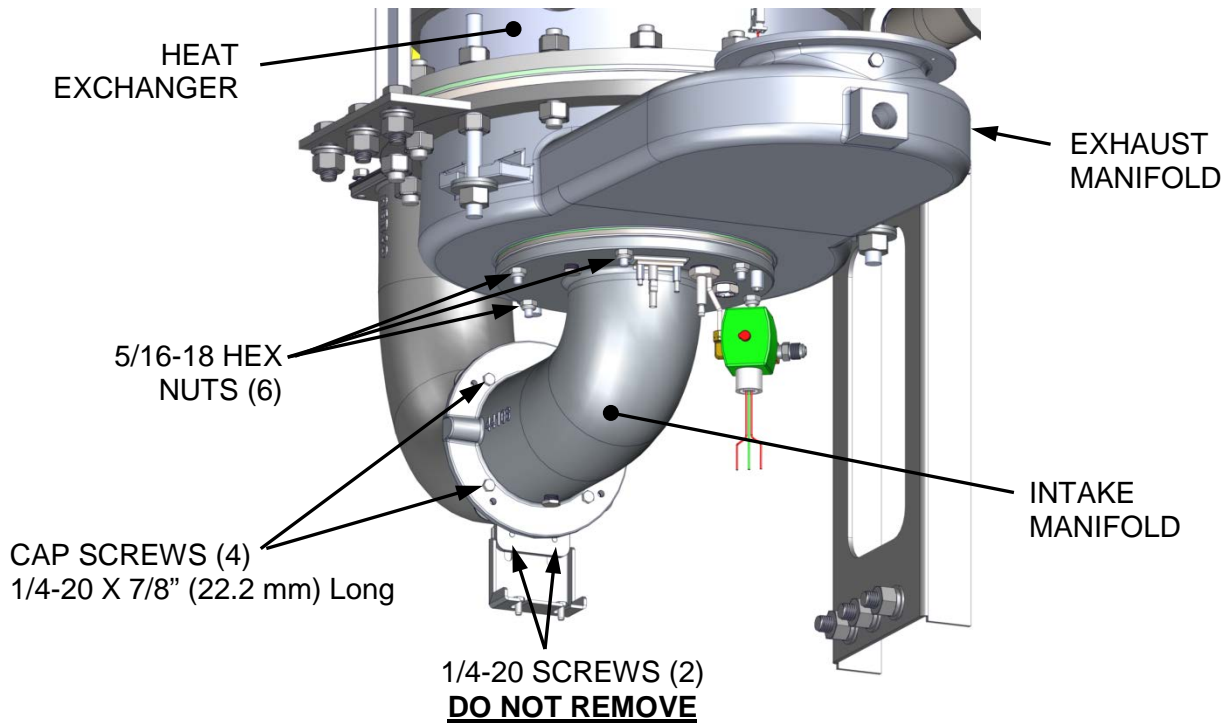
The intake manifold may be hot. Therefore, allow the unit to cool sufficiently before starting the removal process described in the following steps.

### Fireside Inspection Instructions

1. Set the ON/OFF switch on the control panel, to the **OFF** position. Disconnect AC power from the unit and turn off the gas supply.
2. Remove the exhaust vent from the exhaust manifold. Use a scraper or blade to separate the high temperature silicon sealant between the exhaust manifold and vent connector and remove all sealant from both surfaces in preparation for reassembly.
3. Remove the side and rear panels from the unit. Also remove the bottom panel of the cabinet to expose the mechanical room floor beneath the burner. This is needed to provide clearance for pulling the burner.
4. Locate the intake manifold at the bottom of the unit's heat exchanger (see Figures 6-3 and 6-4).
5. Disconnect the lead wire from the flame detector installed on the intake manifold flange (Figure 6-2).
6. Remove the two (2) hex standoffs securing the flame detector to the intake manifold (see Figures 6-1 and 6-2).
7. Remove the flame detector and gasket from the intake manifold flange.
8. Disconnect the cable from the igniter-injector, loosen the compression nut and elbow from the gas injector tube (Figure 6-1), and remove the entire ignition assembly (nut/elbow, solenoid valve, hose nipple, and gas flex hose) from the manifold flange.
9. Loosen and remove the igniter-injector from the intake manifold flange. Retain the clocking washers (if present), for later reassembly.
10. Refer to Figure 6-3. Loosen and remove the four (4) 1/4-20 cap screws securing the blower side of the intake manifold (P/N **44106**). **DO NOT REMOVE** the two 1/4-20 screws and nuts securing the manifold support bracket.



**Fireside Inspection Instructions**



PARTIAL RIGHT-SIDE VIEW – BASE & SUPPORT BRACKET REMOVED FOR CLARITY

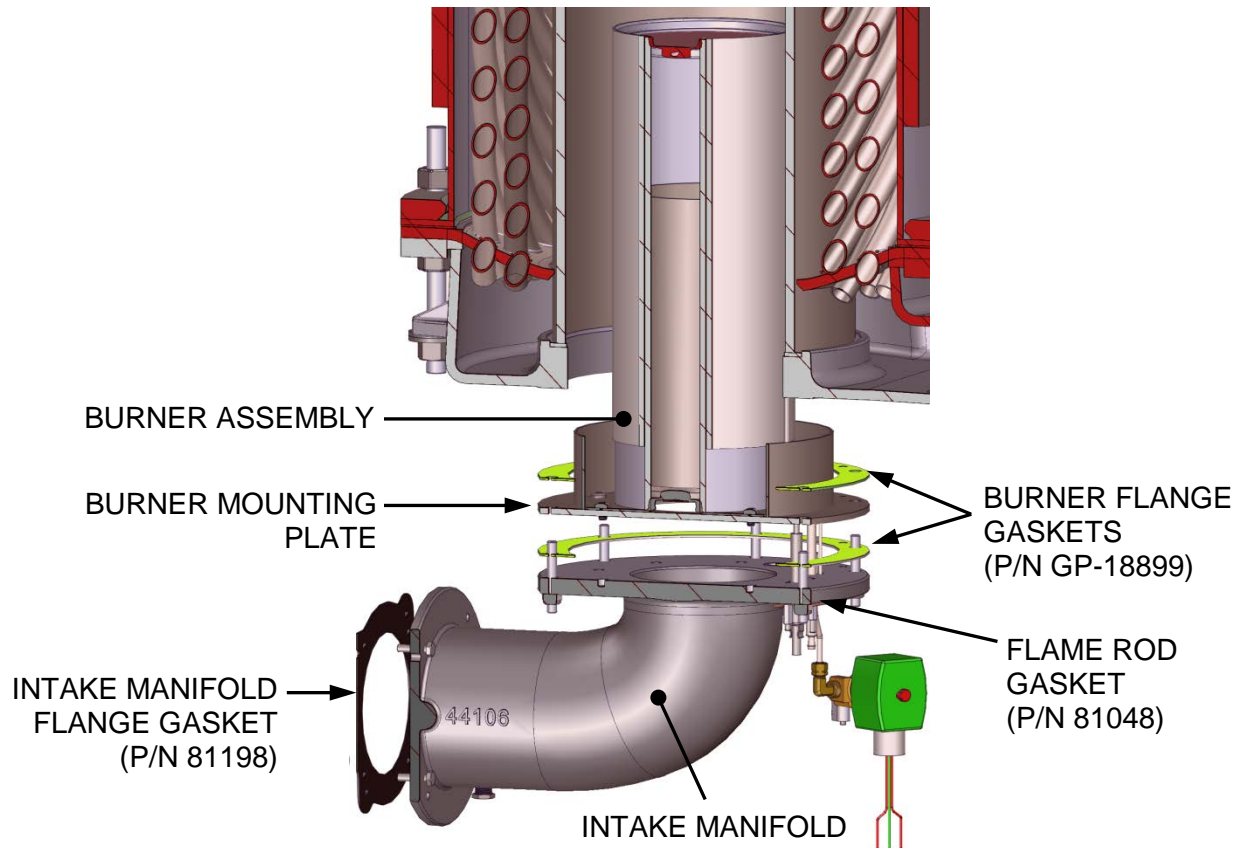
**Figure 6-3. Intake Manifold & Exhaust Manifold Locations**

**CAUTION!**

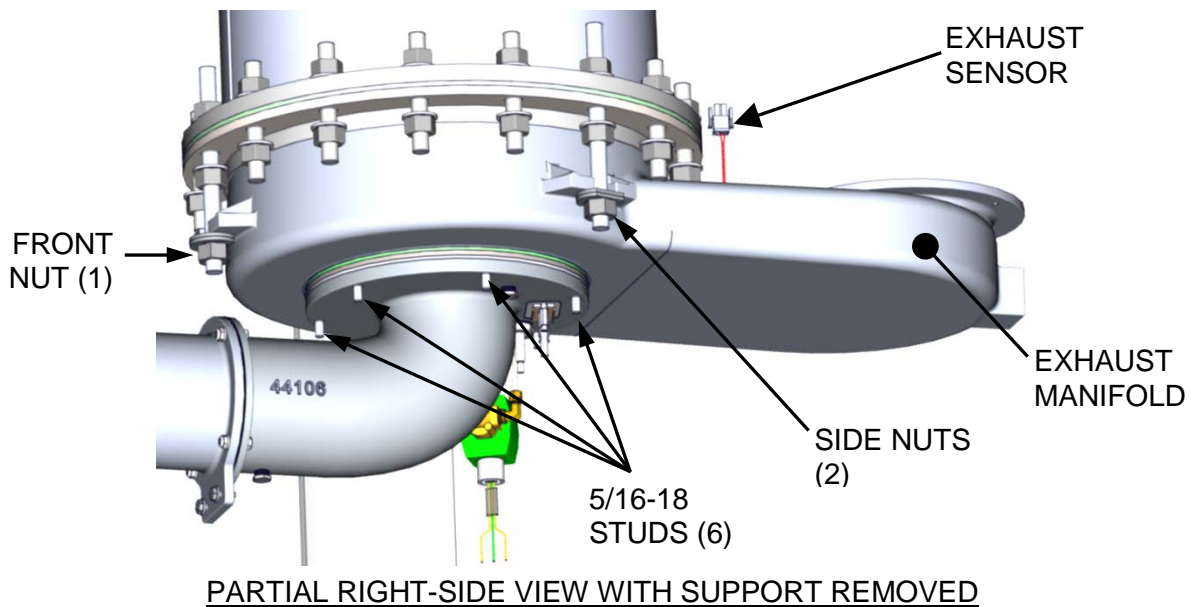
The intake manifold, burner and exhaust manifold assemblies weigh approximately 25 pounds. Use care when removing these assemblies in the following steps.

11. While supporting the intake manifold, loosen and remove the six (6) 5/16-18 hex nuts securing it to the studs protruding from the exhaust manifold.
12. Carefully lower and remove the intake manifold, burner assembly, two burner gaskets (P/N **GP-18899**), and the intake manifold flange gasket (P/N **81198**). See Figures 6-3 and 6-4.
13. Disconnect the exhaust temperature sensor (Figure 6-3) by unscrewing it from the exhaust manifold.
14. While supporting the exhaust manifold, remove the two (2) side nuts (Figure 6-5) securing the manifold to the heat exchanger. Loosen, but **do not remove** the third nut nearest to the front of the unit.
15. Remove the exhaust manifold from the unit.
16. Inspect the exhaust manifold and burner assemblies for debris. Clean out debris as necessary.
17. This completes the fireside inspection of the unit. Proceed to step 18 and reassemble the unit as indicated.

**Fireside Inspection Instructions**

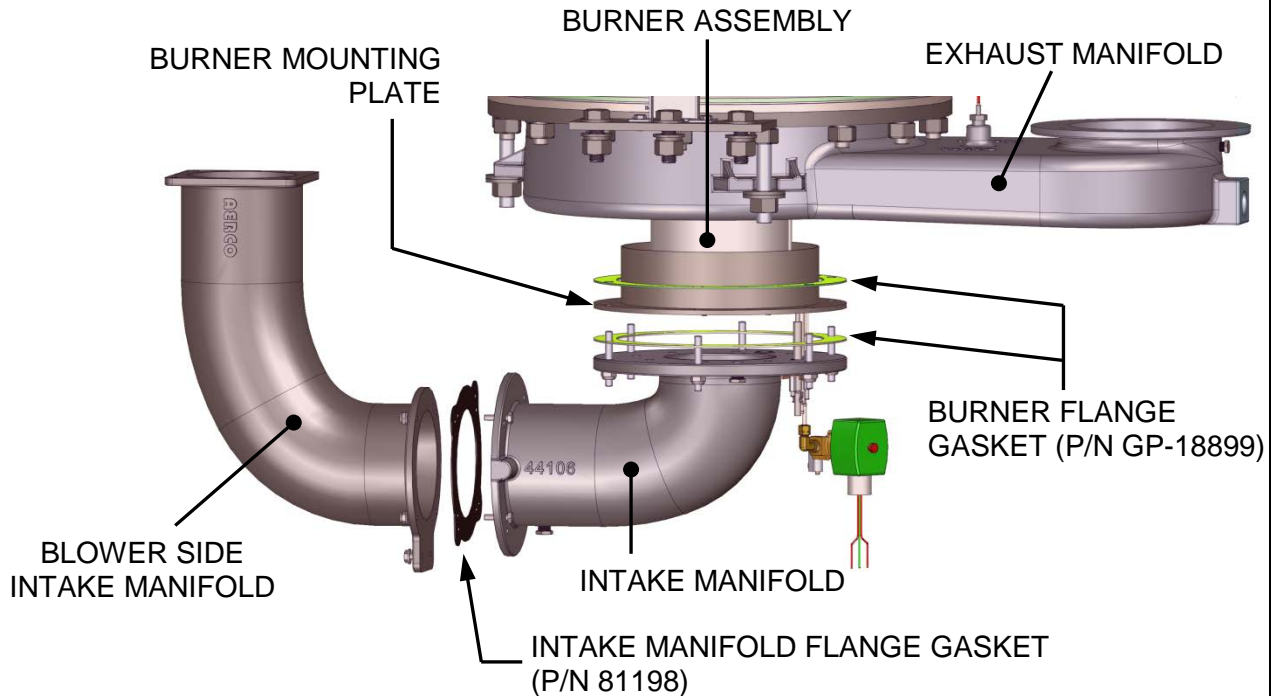


**Figure 6-4. Intake Manifold and Burner – Cross-Section, Exploded**



**Figure 6-5. Intake and Exhaust Manifolds**

**Fireside Inspection Instructions**



BURNER, INTAKE AND EXHAUST MANIFOLDS – CROSS-SECTION, EXPLODED

**Figure 6-6. Combustion Chamber Gasket Locations**

**IMPORTANT!**

During reassembly, apply high-temperature, anti-seize lubricant to the threads of the igniter-injector and grounding screw. Also, ensure that the igniter-injector is properly positioned and not contacting other components. **Torque the igniter-injector to 15 ft/lbs. (20.3 Nm).**

18. Reinstall all components in the reverse order in which they were removed, beginning with the exhaust manifold assembly removed in step 15.
19. When attaching the intake manifold to the exhaust manifold (removed in step 11), **torque the six 5/16 hex nuts to 146 in/lbs. (16.5 Nm).**

**WARNING!**

The manifold-to-heat exchanger gasket must be held in place with High Temp RTV Silicone sealant. The exhaust manifold must be carefully raised into place, centered, and leveled to insure the gasket makes a good seal between the manifold and heat exchanger.

20. Reinstall the exhaust vent onto the exhaust manifold using a High Temp Red RTV silicon sealant, such as sealants available from Permatex or Loctite.
21. Start the unit and fire it **for approximately 20 minutes**, to bring it up to working temperature, then shut it down and repeat Step 19, **re-torquing the six 5/16 hex nuts attaching the intake manifold to the exhaust manifold to 146 in/lbs. (16.5 Nm).**

## 6.7 WATERSIDE PORT INSPECTION

Inspection of the lower tubesheet area is done using the 2" NPT inspection port in the lower section of the shell, as shown in Figure 6-7.

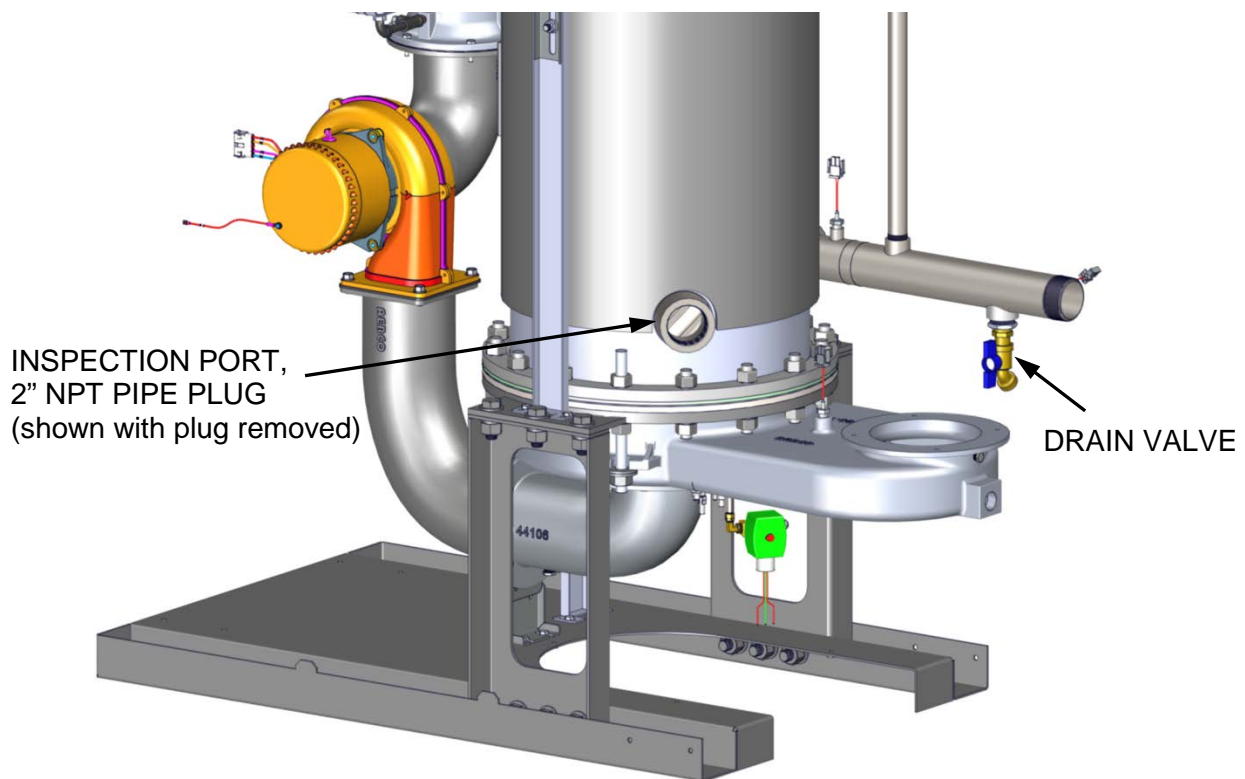
### Waterside Port Inspection Instructions

1. Disconnect the electrical power to the unit.
2. Close the water inlet, outlet, and recirculation shut-off valves to the unit.
3. Carefully open the drain valve while opening the relief valve on the rear of the unit to relieve pressure and allow air into the shell.

#### CAUTION!

Do not drain the unit without venting the shell! A vacuum in the unit may displace the head liner causing serious damage not covered by warranty.

4. Referring to see Figure 6-7, below, remove the 2" NPT plug near the base of the heat exchanger shell (a little additional water may flow from the port).
5. Using a camera and flashlight, or a boroscope, inspect and take photos of the visible tube and tubesheet area.
6. If sediment and deposits exist on the lower tubesheet, follow instructions (Section 6.8.1) for descaling and flushing the unit to remove excess debris.



**Figure 6-7: Lower Waterside Inspection Port Location**

## 6.8 WATERSIDE HEAT EXCHANGER INSPECTION AND CLEANING

The Heat Exchanger heating surface is inspected by removing the top head (see Figure 6-8a and 6-8b). Prior to performing the inspection, ensure that the following replacement part(s) are available:

OLDER Units	NEWER Units
Head Release gasket P/N <b>GP-18556</b> (Qty = 1) Head gasket, P/N <b>GP-18532</b> (Qty = 1)	Head Gasket, P/N <b>81205</b> (Qty = 1)

To inspect the waterside of the heat exchanger, proceed as follows:

### Waterside Inspection Instructions

1. Disconnect the electrical power to the unit.
2. Close the water inlet, outlet, and recirculation shut-off valves to the unit.
3. Carefully open the drain valve while opening the relief valve on the rear of the unit to relieve pressure and allow air into the shell.

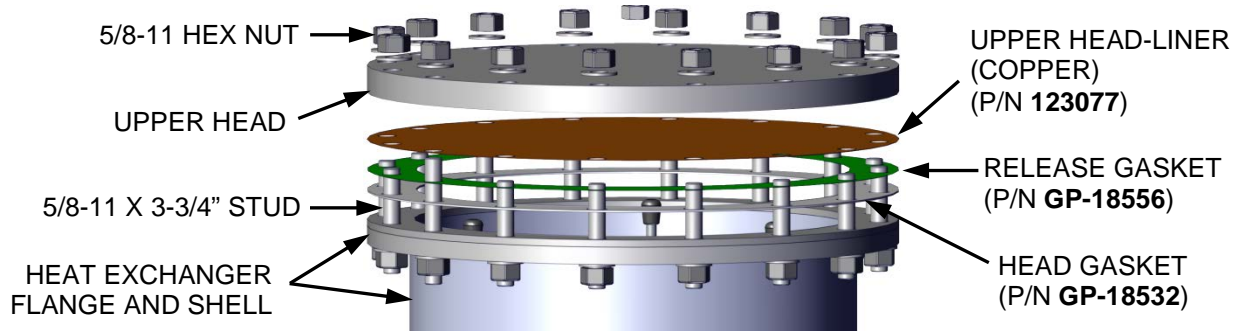
#### CAUTION!

Do not drain the unit without venting the shell! A vacuum in the unit may displace the head liner causing serious damage not covered by warranty.

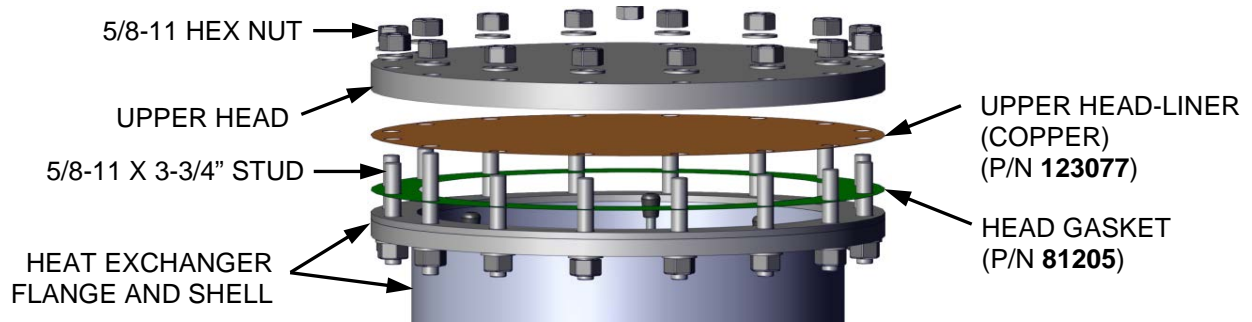
4. Referring to see Figure 6-8a or 6-8b, below, remove the 5/8-11 hex nuts and washers from the upper head, and then remove the upper head, the copper upper Head-Liner and gaskets.
5. Pull the baffle assembly out of the chamber, exposing the heat exchanger tubes.
6. Inspect and clean the heat exchanger tubes of scale and clean all gasket surfaces thoroughly before reassembling the upper head. Refer to Section 6.8.1 for heat exchanger cleaning instructions. AERCO recommends that a NEW gasket be used when reassembling.
7. Place two Baffle Spacer strips (P/N **49274**, included with kit # **24427-TAB**) on top of the heat exchanger tubes, one on either side.
8. Rotate the baffle assembly so that the threaded studs will be away from the sensor and water outlet and then push it down into the heat exchanger until it comes in firm contact with the Baffle Spacer strips. The thickness of these strips (1/8") represents the correct gap between the baffle assembly and the heat exchanger tubes. They are soluble and will dissolve quickly when the unit is restarted.
9. Place the Head gasket (P/N **81205**) on top of the heat exchanger shell flange. Note, both OLDER and NEWER configurations will use this single gasket.
10. If necessary, use a straight edge to adjust the threaded rods until the tops of the spindle caps are aligned with the top surface of the Head gasket. If the caps protrude above the top edge of the Head gasket, it may damage the copper upper Head Liner.
11. Place the copper upper Head Liner on, aligning the holes with the 5/8-11 X 3-3/4" (9.53 cm) studs.
12. Replace the nuts and washers on the 5/8-11 X 3-3/4" (9.53 cm) studs.
13. Cross tighten the nuts to approximately **75 ft.-lb. (101 Nm) torque** to obtain a uniform seating, then progressively tighten the nuts to **200 ft.-lb. (271 Nm) torque**.
14. Close the drain valve and reopen the inlet, outlet, and recirculation valve.



**Waterside Inspection Instructions**



**Figure 6-8a: Heat Exchanger Head Configuration – OLDER Configuration**



**Figure 6-8b: Heat Exchanger Head Configuration – NEWER Configuration**

**6.8.1 HEAT EXCHANGER CLEANING**

For hard water installations, AERCO highly recommends use of Watts OneFlow<sup>®</sup> anti-scaling system. Watts OneFlow<sup>®</sup> is strongly recommended for installations in areas with hard water (>3.5 grains/gal, >59.9 mg/L). It provides an economical, chemical free treatment of hard water allowing the water heater to perform at its peak efficiency (low-water heating cost). In addition to reduced inspection frequency, the periodic maintenance to remove and flush the water heater for scale deposits is no longer necessary.

Alternatively, AERCO recommends that the unit’s heat exchanger be cleaned per the guidelines in Table 6-2, below, to maintain maximum heat transfer efficiencies using a solution of HydroSkrub and water. HydroSkrub is distributed by AERCO International, Inc. and is designed to dissolve the toughest water scale, lime, mud and rust deposits from virtually any type of water-based equipment.

The frequency of cleaning can be determined locally based on the performance of the heater and/or prior experience with similar equipment. Generally, the cleaning requirements will follow the trends shown in Table 6-2:

<b>Table 6-2. Heat Exchanger Cleaning Guidelines</b>				
<b>Operating Conditions</b>	<b>Projected Cleaning Frequency</b>			
	<b>24-months</b>	<b>12-months</b>	<b>6-months</b>	<b>Monthly</b>
Domestic Water Setpoint	<130°F	140 - 160°F	160 - 180°F	
Calcium Hardness Level (as seen by Innovation)	<120 mg/L	60 - 170 mg/L	60 - 257 mg/L	>257 mg/L

**NOTE**

If calcium hardness level, and domestic water setpoint fall under different cleaning intervals in Table 6-2, the heat exchanger may be cleaned between those periods, starting with the most frequent interval. During the next few cleaning intervals observe how much scale is removed to determine if less frequent intervals can be followed.

Example:

Domestic water setpoint = 125°F

Calcium Hardness level = 171 mg/L

Heat exchanger Cleaning Frequency: Start out with annual schedule (125°F SP falls under “24-months” and the calcium hardness level falls under “12-months”). Observe the next few cleanings on how much scale is removed to determine if an 18-month cleaning frequency is more appropriate.

**CAUTION!**

Please review MSDS, specifications, and our website ([www.aerco.com](http://www.aerco.com)) for additional information, or call technical service at (800) 526-0288.

**CAUTION!**

Do not drain the unit without venting the shell! A vacuum in the unit may displace the head liner causing serious damage not covered by warranty.



**6.8.1.1 Pumping System Set-Up Instructions**

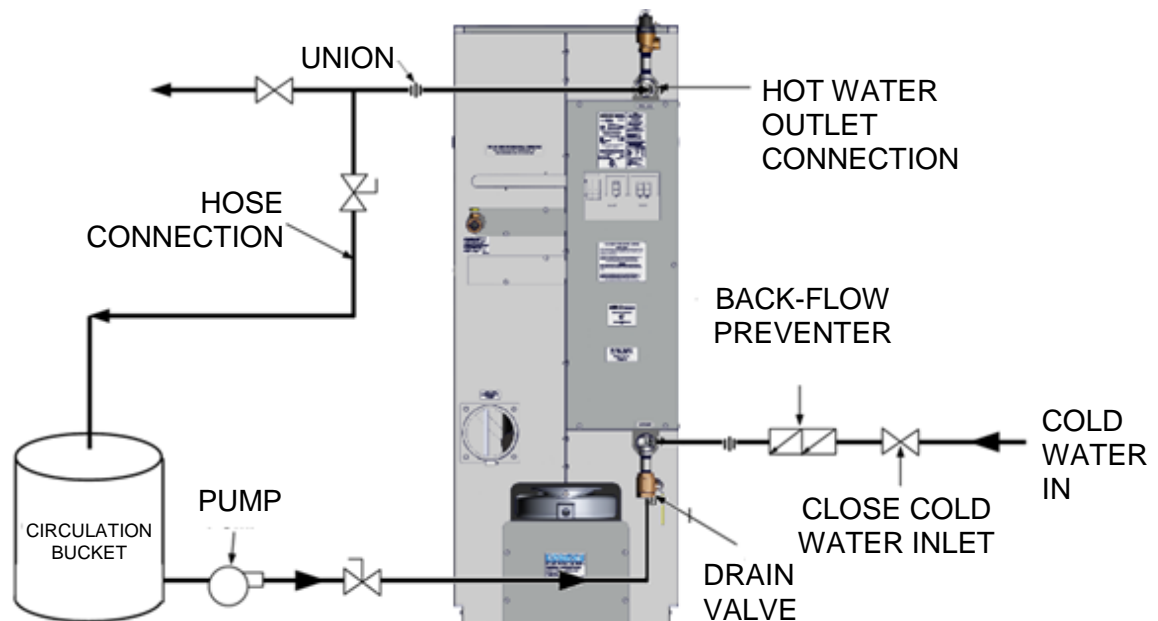
A sample pumping set-up diagram is shown in Figure 6-9 for an Innovation Water Heater. As this diagram shows, heat exchanger cleaning is accomplished by pumping the HydroSkrub solution from a large circulating bucket to the heat exchanger drain valve, through the heat exchanger and then out through the output connection of the heater. Set up the pumping system as follows:

**Set-Up Instructions Instructions**

1. Turn off the water heater and close the inlet and outlet isolation valves.
2. Open the drain valve at the rear of the heater and drain at least half of the heat exchanger water-side volume. When full Innovation models hold approximately the gallons of water listed below. During cleaned, drain at least the amount of water shown above for the model being cleaned.

Model	Capacity	Volume to be Drained
<b>INN600</b>	24.5 gallons (92.7 L)	12.25 gallons (46.37 L)
<b>INN800</b>	24.5 gallons (92.7 L)	12.25 gallons (46.37 L)
<b>INN1060</b>	23.0 gallons (87.01 L)	11.5 gallons (43.53 L)
<b>INN1400</b>	20.6 gallons (77.97 L)	10.3 gallons (38.98 L)

3. Prepare a 50% solution of HydroSkrub and clean water. The amount of the solution should be approximately equal to the full volume of water that the heat exchanger holds.
4. Mix 11 gallons (41.7 L) of HydroSkrub with 11 gallons (41.7 L) of water to provide a 50% solution.
5. Close the unit drain valve and connect a suitable size bucket and pump to the unit drain as shown in Figure 6-9.
6. Install a “T”, ball valve and hose connection in the outlet piping of the heater (Figure 6-9). Route the hose back to the top of the circulation bucket.



**Figure 6-9. Sample Heat Exchanger Cleaning Set-Up**

### 6.8.1.2 Cleaning Procedure

---

#### Cleaning Procedure Instructions

1. Slowly add the prescribe amount of the HydroSkrub solution to the circulating bucket.
2. Open the drain valve, outlet hose connection valve and turn on the pump. Periodically check for leaks and maintain the liquid level in the bucket. A lowering volume level is an indication that there is an open drain in the system.
3. Check the cleaning circuit to ensure that the HydroSkrub solution is flowing from the circulation bucket, through the pump and the heater and back to the top of the top of the bucket.
4. Return discharge foaming indicates an active HydroSkrub solution and the presence of mineral deposits in the equipment.
5. Additional HydroSkrub and/or water may be required to maintain circulation and to prevent the pump from cavitating.
6. Circulate the cleaning solution through the heat exchanger and piping for 1 to 3 hours. Estimate the circulation period based on the time in service and water hardness. When the foaming action stops, HydroSkrub strength is depleted (two pounds of deposits removed per gallon used) or the equipment is free from calcium and other water-formed mineral deposits.
7. Periodically test the solution for effectiveness to determine if more HydroSkrub is needed. Refer to “Testing HydroSkrub Effectiveness” in the next section for details. If the cleaning solution is expended before circulation time is up, additional HydroSkrub will be needed and circulation time may be extended to complete the cleaning.
8. Upon completion of the cleaning process, begin flushing the solution by adding clean water to the circulation bucket, then disconnect the return valve and hose connection from the top of the circulating bucket and thoroughly flush. Continue water flushing the equipment for a minimum of 10 minutes or until discharge runs clear.
9. HydroSkrub is biodegradable, and in most instances may be purged down sewers. Check with local authorities before disposing of any complex compositions
10. Turn off water, shut off the pump and immediately close discharge valves to prevent backflow.
11. Completely drain pump bucket. Disconnect the hoses from equipment and thoroughly rinse the bucket, pump, and associated hoses used.

### 6.8.1.3 Testing HydroSkrub Effectiveness

---

There are two methods of testing the effectiveness of HydroSkrub during cleaning: the calcium carbonate spot test of the circulating solution and the charting of a trend in the pH of the cleaning solution.

#### Calcium Carbonate Spot Test

A calcium carbonate spot test is performed by exposing a form of calcium carbonate to the HydroSkrub solution. Samples of the deposit, a Tums or Roloids tablet, or bare concrete can be used. Observe the reaction of the HydroSkrub solution on the calcium carbonate. Foaming and bubbling indicates the solution is still active. Little or no reaction indicates that the solution is expended. This test should be performed near the end of the circulating time. If the solution has been expended, more HydroSkrub will be required to complete the job. If the solution is still active at the end of the time, all the scale has been dissolved.

#### pH Trend Charting

The initial pH of the cleaning solution will measure between 1-3 (See pH sheet on HydroSkrub packaging). To test the effectiveness of the circulating solution as a function of pH, take readings at regular intervals and chart as a trend. Note that the deposits can cause a premature jump in the pH. After circulating for approximately 75% of the cycle time, begin testing the pH at 10-15 minute intervals. Once the solution's pH reads 6.0-7.0 on three or more consecutive readings, the solution is expended. If the pH reads below 6.0 after the circulating time, the application is clean.

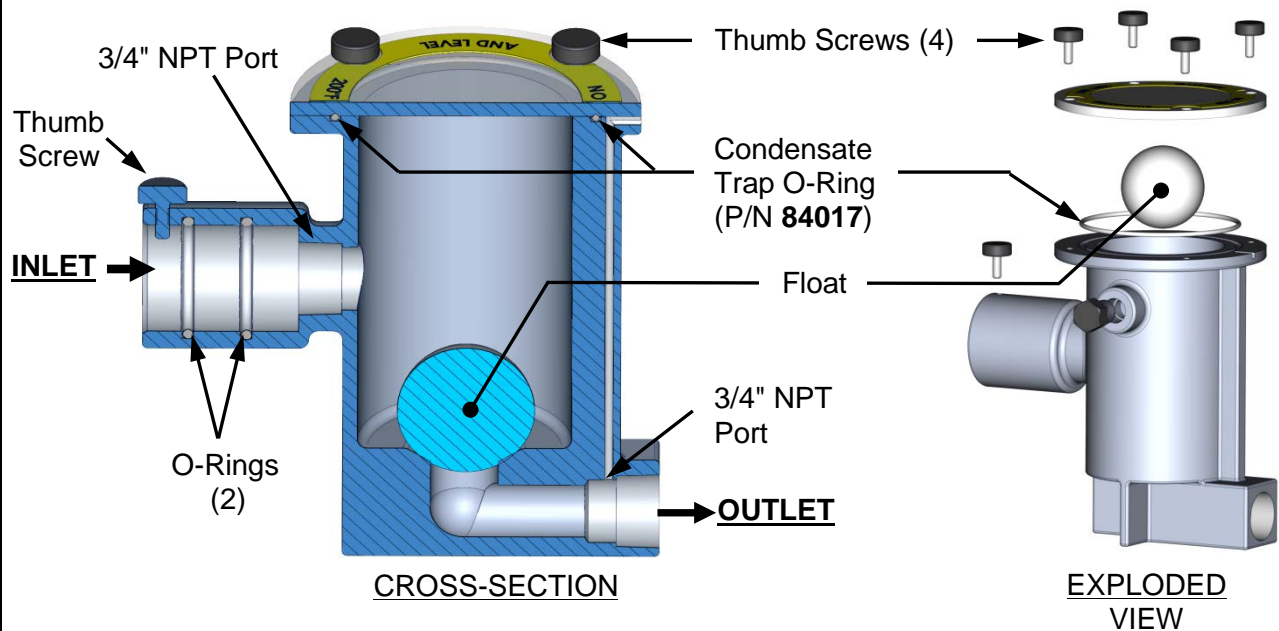
## 6.9 CONDENSATE DRAIN TRAP

Innovation Water Heaters contain one condensate trap, P/N **24441**. The trap is located external to the unit and attached to the drain connection from the exhaust manifold. The location on the unit is shown in Chapter 2, Figure 2-7. This trap should be inspected and, if necessary, cleaned to ensure proper operation.

To inspect and clean the condensate trap, proceed as follows:

### Condensate Trap Inspection and Cleaning Instructions

1. Disconnect the external condensate trap by loosening and then removing connections on the inlet and outlet sides of the trap (see Figure 6-10).
2. Loosen the four (4) thumbscrews securing the trap's cover and then remove the cover and the O-ring from under the cover.
3. Remove the float and then thoroughly clean the trap and float. Also inspect the drain piping for blockage. If the trap cannot be thoroughly cleaned, replace the entire trap (P/N **24441**).
4. Replace the float, install the O-ring (P/N **84017**), and then replace the trap cover.
5. Reassemble all piping and hose connections to the condensate trap inlet and outlet.



**Figure 6-10. Condensate Trap P/N 24441**

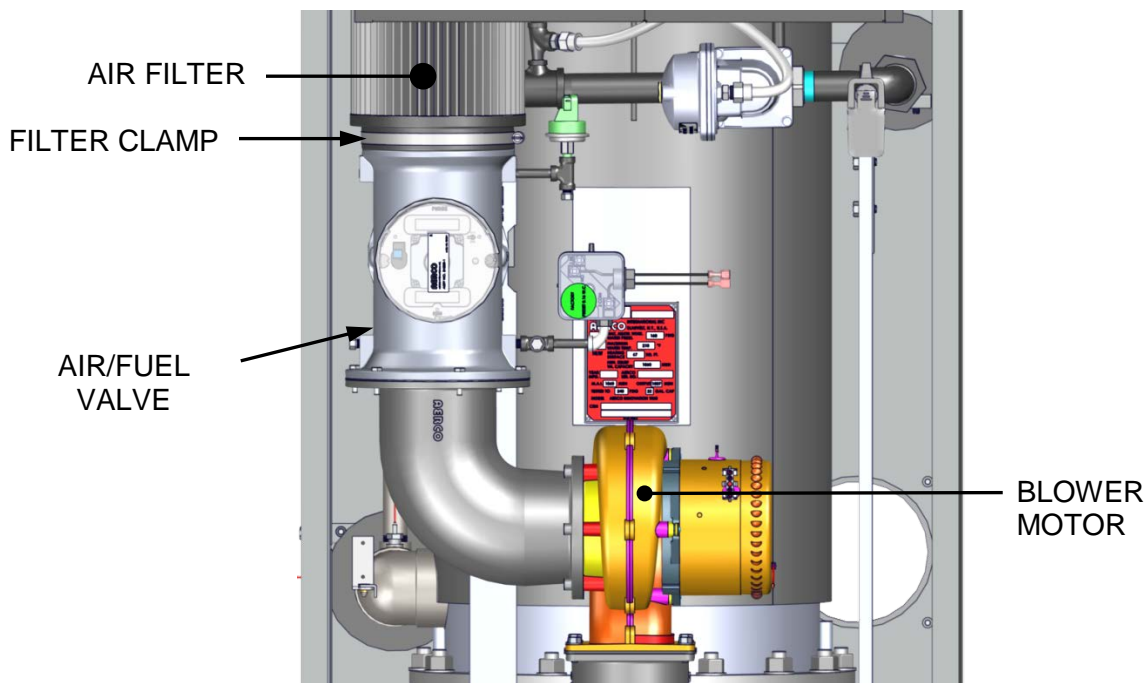
## 6.10 AIR FILTER REPLACEMENT

The Innovation heater is equipped with an air filter (P/N **59138**) which should be cleaned or replaced every 12 months. The air filter is located at the inlet of the air fuel valve as shown in Figure 6-11.

To inspect/replace the air filter, proceed as follows:

### Air Filter Replacement Instructions

1. Set the ON/OFF switch on the control panel, to the **OFF** position. Disconnect AC power from the unit
2. Remove the side panels from the unit.
3. Refer to Figure 6-11 and locate the air filter attached to the air/fuel valve inlet.
4. Using a flat-tip screwdriver or 5/16 nut driver, loosen the clamp securing the filter to the inlet flange of the air/fuel valve. Remove the filter and clamp.
5. Each replacement air filter is equipped with its own clamp. Therefore, simply install the replacement air filter on inlet flange of the air fuel valve and tighten the clamp with a flat-tip screwdriver or 5/16 nut driver.
6. Replace the side panels on the unit and return heater to service use.



BARE HEATER – PARTIAL FRONT VIEW

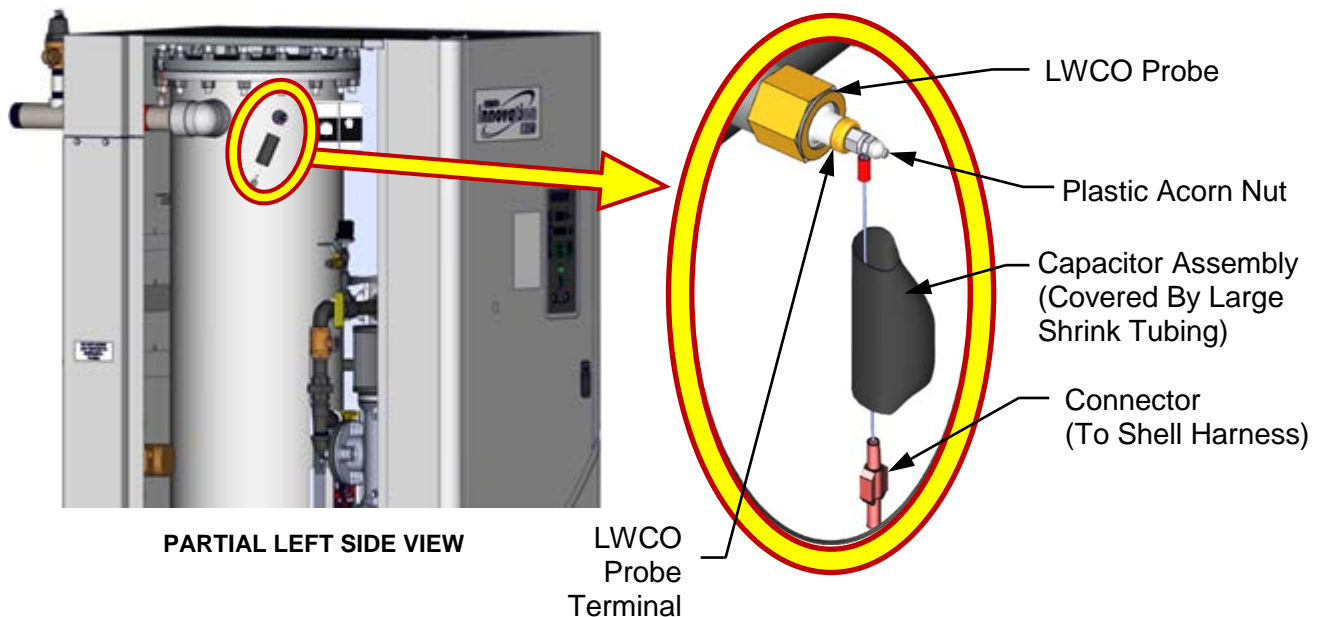
**Figure 6-11. Air Filter Mounting Location**

## 6.11 LOW WATER CUTOFF (LWCO) CAPACITOR INTEGRITY TEST

If the LWCO capacitor has failed, order the LWCO capacitor Kit, P/N **69126**, from AERCO, and consult the Innovation 24 Month Maintenance Technical Instructions Document TID-0094 for replacement instructions.

The LWCO capacitor should be tested for electrical shorts every 12 months and replaced, then tested, every 24 months. The LWCO capacitor integrity test consists of two parts as described in the next two sections. The first procedure explains how to test for electrical shorting of the LWCO probe capacitor, while the second procedure instructs how to perform the standard Low Water Cutoff test using the C-More controls.

On the Innovation series, the LWCO probe is located on the heat exchanger body on the left side of the unit. Refer to Figure 6-12 for an illustration of the LWCO probe assembly and its installation.



**Figure 6-12: LWCO Probe Location (INN 1400 Shown)**

### 6.11.1 Low Water Cutoff (LWCO) - Capacitor Electrical Short Test

This test determines if there is an electrical short between the LWCO capacitor and the heat exchanger. Perform the capacitor electrical short test as described below.

#### LWCO Capacitor Electrical Short Test Instructions

1. Turn OFF AC power to the unit.

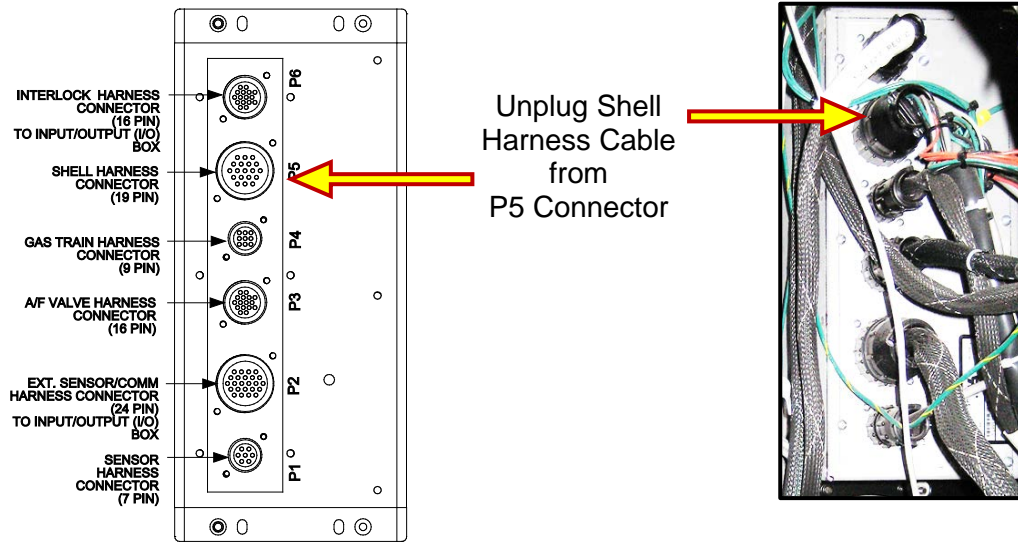
#### **WARNING!**

Voltages of 220, 110 and 24 are used to power these units, so power applied to these units ***MUST*** be removed before performing the procedure described below. Serious personal injury or death may occur if this warning is not observed.

2. Remove the Shell Harness Cable (male) connector from the P-5 (female) connector on the rear panel of the C-More controller (see Figure 6-13).

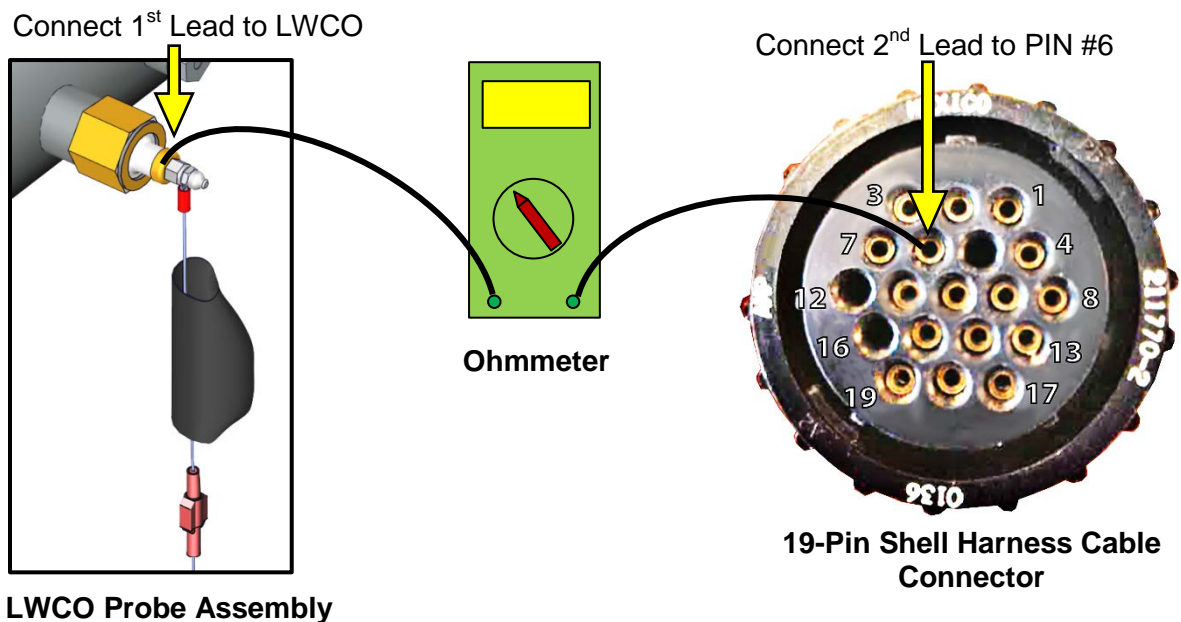


**LWCO Capacitor Electrical Short Test Instructions**



**Figure 6-13: Removing Shell Harness Cable from P5 Conn. on C-More Rear Panel**

- Using an ohmmeter, connect one ohmmeter probe to the LWCO capacitor terminal on the unit shell as shown on left in Figure 6-14.
- Connect the second ohmmeter probe to Pin #6 of Shell Harness Connector (removed from the C-More controller) as shown on right in Figure 6-14.



**Figure 6-14: Connecting Ohmmeter between LWCO Probe & Shell Harness Cable**

- Confirm that the ohmmeter does NOT read a short.

### LWCO Capacitor Electrical Short Test Instructions

**NOTE:**

If the ohmmeter reads a short, the capacitor assembly needs to be replaced. Refer to document TID-0094, provided with the 24-month maintenance kit, for LWCO replacement instructions.

6. Remove both ohmmeter probes and reconnect the Shell Harness connector to the P5 connector on the rear of the C-More controller.

### 6.11.2 Low Water Cutoff (LWCO) - Standard C-More Test

Perform the standard Low Water Cutoff test using the C-More controls as described below.

#### Standard Low Water Cutoff C-More Test Instructions

1. Turn on the AC power to the unit.
2. Press the **TEST** switch on the C-More controller and confirm that the blinking "Low Water Level" message appears on the C-More display within 4 seconds.
3. Press the **RESET** key, followed by the Clear button, and confirm that the "Low Water Level" message is cleared.

## 6.12 SHUTTING THE WATER HEATER DOWN FOR AN EXTENDED PERIOD OF TIME

If the heater is to be taken out of service for an extended period of time (one year or more), complete the following instructions.

#### Extended Period Shut-Down Instructions

1. Set ON/OFF switch on the front panel to the **OFF** position to shut down the heater's operating controls.
2. Disconnect AC power from the unit.
3. Close the water inlet and outlet valves to isolate unit.
4. Close external gas supply valve.
5. Open relief valve to vent water pressure.
6. Open the drain valve and drain all water from the unit.



## 6.13 PLACING THE HEATER BACK IN SERVICE AFTER A PROLONGED SHUTDOWN

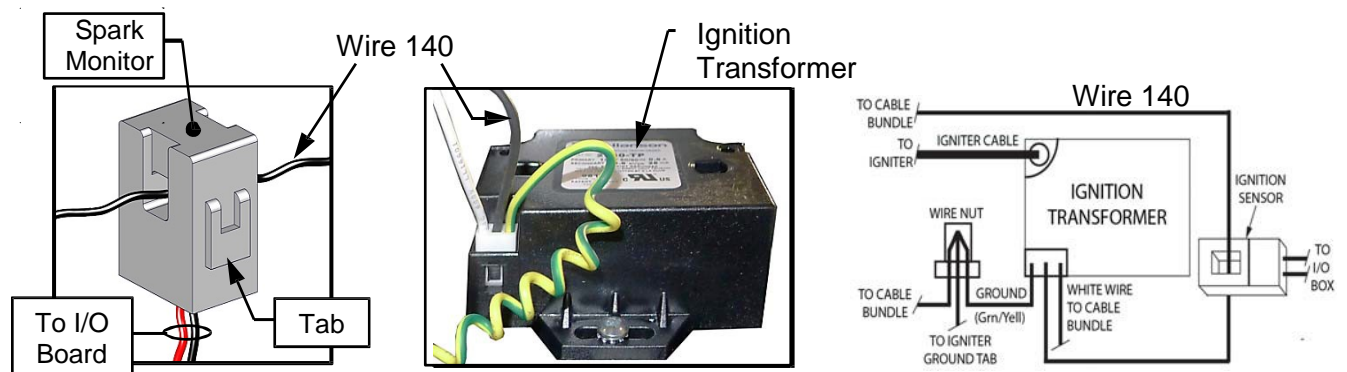
After a prolonged shutdown (one year or more), the following procedures must be followed:

### Placing Heater Back In Service After Prolonged Shutdown Instructions

1. Review installation requirements included in Chapter 2.
2. Inspect all piping and connections to the unit.
3. Inspect exhaust vent, air duct (if applicable).
4. Perform initial startup per Chapter 4.
5. Perform safety device testing and scheduled maintenance procedures per Chapters 5 and 6 of this manual.

## 6.14 SPARK MONITOR (AC CURRENT TRANSDUCER)

The spark monitor (P/N **61034**) evaluates the strength of the current between the ignition transformer and igniter or igniter-injector. Wire# 140, connected to the ignition transformer (see Figure 6-15), passes through the monitor's orifice. If an adequate AC current is not detected in the wire during ignition, the unit automatically shuts down. The monitor's wires are connected to the I/O board's Spark Signal terminals (see Section 2.12.4).



**Figure 6-15: Spark Detector Sensor (AC Current Transducer) P/N 61034**

If the spark monitor needs to be replaced, open the monitor's orifice by pulling on the tab at the side, remove Wire# 140, disconnect the monitor's wires from the I/O board, remove the old monitor from its position, install a new monitor in its place, route wire# 140 through the new sensor orifice, and connect the wires to the I/O board's Spark Signal terminals, red wire to the positive (+) terminal and black to negative (-).

## CHAPTER 7. TROUBLESHOOTING GUIDE

### 7.1 INTRODUCTION

This troubleshooting guide is intended to aid service/maintenance personnel in isolating the cause of a fault in an Innovation Water Heater. The troubleshooting procedures contained herein are presented in tabular form on the following pages. These tables are comprised of three columns labeled: Fault Indication, Probable Cause and Corrective Action. The numbered items in the Probable Cause and Corrective Action columns correspond to each other. For example, Probable Cause No. 1 corresponds to Corrective Action No. 1, etc.

When a fault occurs in the unit, proceed as follows to isolate and correct the fault:

#### General Troubleshooting Instructions

1. Observe the fault messages displayed in the C-More Controller display.
2. Refer to the Fault Indication column in Troubleshooting Table 7-1 which follows and locate the Fault that best describes the existing conditions.
3. Proceed to the Probable Cause column and start with the first item (1) listed for the Fault Indication.
4. Perform the checks and procedures listed in the Corrective Action column for the first Probable Cause candidate.
5. Continue checking each additional Probable Cause for the existing fault until the fault is corrected.
6. Section 7.2 and Table 7-2 contain additional troubleshooting information which may apply when no fault message is displayed.

If the fault cannot be corrected using the information provided in the Troubleshooting Tables, contact your local AERCO Representative.

#### NOTE:

The front panel of the C-More Controller contains an RS232 port. This port is used only by factory-trained personnel to monitor OnAER communications via a portable computer.

(This Page Is Intentionally Blank)

TABLE 7-1. WATER HEATER TROUBLESHOOTING		
FAULT INDICATION	PROBABLE CAUSES	CORRECTIVE ACTION
AIRFLOW FAULT DURING IGNITION	<ol style="list-style-type: none"> <li>1. Blower stopped running due to thermal or current overload.</li> <li>2. Blocked <b>Blower Inlet</b> or inlet ductwork.</li> <li>3. Blocked <b>Blower Proof</b> switch.</li> <li>4. Blocked <b>Blocked-Air Inlet</b> switch.</li> <li>5. Defective <b>Blower Proof</b> switch.</li> <li>6. Defective <b>Blocked-Air Inlet</b> switch.</li> <li>7. Loose temperature to AUX connection in I/O Box.</li> <li>8. Defective temperature sensor.</li> <li>9. Loose wire connection between the 0-10V signal from I/O box to the Blower Motor input.</li> <li>10. Defective I/O box.</li> <li>11. Wrong 0-10V output selection on the C-More Controller.</li> <li>12. Defective Air-Fuel Valve potentiometer.</li> </ol>	<ol style="list-style-type: none"> <li>1. Check combustion blower for signs of excessive heat or high current drain that may trip thermal or current overload devices.</li> <li>2. Inspect the inlet to the combustion blower including any ductwork leading up to the combustion blower for signs of blockage.</li> <li>3. Remove the <b>Blower Proof</b> switch and inspect for signs of blockage, clean or replace as necessary.</li> <li>4. Remove the <b>Blocked-Air Inlet</b> switch and inspect for signs of blockage, clean or replace as necessary.</li> <li>5. Measure the <b>Blower Proof</b> switch for continuity with the combustion blower running. If there is an erratic resistance reading or the resistance reading is greater than zero ohms, replace the switch.</li> <li>6. Measure the <b>Blocked-Air Inlet</b> switch for continuity with the combustion blower running. If there is an erratic resistance reading or the resistance reading is greater than zero ohms, replace the switch.</li> <li>7. Check the actual inlet air temperature and measure voltage at AUX input in the I/O Box. Verify that the voltage conforms to the values shown in the tabular listing provided in Appendix C.</li> <li>8. Refer to CORRECTIVE ACTION 7 and verify that the voltage conforms to the values shown in Appendix C.</li> <li>9. Check wire connection from I/O Box 0-10V signal to the Blower Motor.</li> <li>10. Measure voltage at the I/O box 0-10V output. A voltage of 8.2V equates to a 100% open valve position.</li> <li>11. Check the <i>Analog Out</i> option on the C-More Configuration Menu. <i>Valve Position 0-10V</i> should be selected.</li> <li>12. Check Air/Fuel Valve position at 0%, 50% and 100% open positions. The positions on the VALVE POSITION bargraph should match the dial readings on the Air/Fuel Valve dial.</li> </ol>

TABLE 7-1. WATER HEATER TROUBLESHOOTING		
FAULT INDICATION	PROBABLE CAUSES	CORRECTIVE ACTION
AIRFLOW FAULT DURING PURGE	<ol style="list-style-type: none"> <li>1. Blower not running or running too slow.</li> <li>2. Defective <b>Air Flow</b> switch.</li> <li>3. Blocked <b>Air Flow</b> switch.</li> <li>4. Blocked blower inlet or inlet ductwork.</li> <li>5. No voltage to switch from C-More Controller.</li> <li>6. PROBABLE CAUSES from AIRFLOW FAULT DURING IGNITION above, items 3 to 12, applies to this fault.</li> </ol>	<ol style="list-style-type: none"> <li>1. Start the unit. If the blower does not run check the blower solid state relay for input and output voltage. If the relay is okay, check the blower.</li> <li>2. Start the unit. If the blower runs, check the airflow switch for continuity. Replace the switch if there is no continuity.</li> <li>3. Remove the air flow switch and inspect for signs of blockage, clean or replace as necessary.</li> <li>4. Inspect the inlet to the combustion blower including any ductwork leading up to the combustion blower for signs of blockage.</li> <li>5. Measure for 24 VAC during start sequence from each side of the switch to ground. If 24 VAC is not present refer to qualified service personnel.</li> <li>6. See CORRECTIVE ACTIONS from AIRFLOW FAULT DURING IGNITION above, items 3 to 12.</li> </ol>
AIRFLOW FAULT DURING RUN	<ol style="list-style-type: none"> <li>1. Blower stopped running due to thermal or current overload.</li> <li>2. Blocked Blower inlet or inlet ductwork.</li> <li>3. Blocked airflow switch.</li> <li>4. Defective airflow switch.</li> <li>5. Combustion oscillations.</li> <li>6. PROBABLE CAUSES from AIRFLOW FAULT DURING IGNITION above, items 3 to 12, applies to this fault.</li> </ol>	<ol style="list-style-type: none"> <li>1. Check combustion blower for signs of excessive heat or high current draw that may trip thermal or current overload devices.</li> <li>2. Inspect the inlet to the combustion blower including any ductwork leading up to the combustion blower for signs of blockage.</li> <li>3. Remove the airflow switch and inspect for signs of blockage, clean or replace as necessary.</li> <li>4. Measure the airflow switch for continuity with the combustion blower running. If there is an erratic resistance reading or the resistance reading is greater than zero ohms, replace the switch.</li> <li>5. Run unit to full fire. If the unit rumbles or runs rough, perform combustion calibration.</li> <li>6. See CORRECTIVE ACTIONS from AIRFLOW FAULT DURING IGNITION above, items 3 to 12.</li> </ol>

<b>TABLE 7-1. WATER HEATER TROUBLESHOOTING</b>		
<b>FAULT INDICATION</b>	<b>PROBABLE CAUSES</b>	<b>CORRECTIVE ACTION</b>
<p>DELAYED INTERLOCK OPEN</p>	<ol style="list-style-type: none"> <li>1. Delayed Interlock Jumper not installed or removed.</li> <li>2. Device proving switch hooked to interlocks is not closed.</li> </ol>	<ol style="list-style-type: none"> <li>1. Check for a jumper properly installed across the delayed interlock terminals in the I/O box.</li> <li>2. If there are 2 external wires on these terminals, check to see if an end switch for a device such as a pump, louver, etc. is tied these interlocks. Ensure that the device and or its end switch are functional. (Jumper may be temporarily installed to test interlock.)</li> </ol>
<p>FLAME LOSS DURING IGN</p>	<ol style="list-style-type: none"> <li>1. Burner Ground Screw not installed or loose.</li> <li>2. Worn flame detector.</li> <li>3. No spark from Spark Plug.</li> <li>4. Defective Ignition Transformer</li> <li>5. Defective Ignition/Stepper (IGST) Board.</li> <li>6. Defective SSOV.</li> <li>7. Carbon or other debris on Burner.</li> </ol>	<ol style="list-style-type: none"> <li>1. Inspect and install/retighten Burner Ground Screw.</li> <li>2. Remove and inspect the flame detector for signs of wear. Replace if necessary.</li> <li>3. Close the internal gas valve in the unit. Install and arc a spark igniter-injector outside the unit.</li> <li>4. If there is no spark, check for 120 VAC at the primary side to the ignition transformer during the ignition cycle.</li> <li>5. If 120 VAC is not present, the IGST Board in the C-More Controller may be defective. Refer fault to qualified service personnel.</li> <li>6. While externally arcing the spark igniter-injector, observe the open/close indicator in the Safety Shut-Off Valve to ensure it is opening. If the valve does not open, check for 120 VAC at the valves input terminals. If 120 VAC is not present, the IGST board in the C-More Controller may be defective. Refer fault to qualified service personnel.</li> <li>7. Remove the burner and inspect for any carbon or debris. Clean and reinstall.</li> </ol>

TABLE 7-1. WATER HEATER TROUBLESHOOTING		
FAULT INDICATION	PROBABLE CAUSES	CORRECTIVE ACTION
FLAME LOSS DURING RUN	<ol style="list-style-type: none"> <li>1. Worn Flame Detector or cracked ceramic.</li> <li>2. Defective Regulator.</li> <li>3. Poor combustion calibration.</li> <li>4. Debris on burner.</li> <li>5. Blocked condensate drain.</li> </ol>	<ol style="list-style-type: none"> <li>1. Remove and inspect the Flame Detector for signs of wear or cracked ceramic. Replace if necessary.</li> <li>2. Check gas pressure readings using a gauge or manometer into and out of the Air/Fuel Valve to ensure that the gas pressure into and out of the valve is correct.</li> <li>3. Check combustion calibration. Adjust as necessary.</li> <li>4. Remove the burner and inspect for any carbon or debris. Clean and reinstall.</li> <li>5. Remove blockage in condensate drain.</li> </ol>
HEAT DEMAND FAILURE	<ol style="list-style-type: none"> <li>1. The Heat Demand Relays on the Ignition/Stepper board failed to activate when commanded.</li> <li>2. Relay is activated when not in Demand.</li> </ol>	<ol style="list-style-type: none"> <li>1. Press <b>CLEAR</b> button and restart the unit. If the fault persists, replace Ignition/Stepper (IGST) Board.</li> <li>2. Defective relay. Replace IGST Board.</li> </ol>
HIGH EXHAUST TEMPERATURE	<ol style="list-style-type: none"> <li>1. Poor combustion calibration.</li> <li>2. Heat exchanger has scale.</li> </ol>	<ol style="list-style-type: none"> <li>1. Check combustion calibration using procedures in Chapter 4.</li> <li>2. Clean heat exchanger using procedures in Chapter 6.</li> </ol>
HIGH GAS PRESSURE	<ol style="list-style-type: none"> <li>1. Incorrect supply gas pressure.</li> <li>2. Defective SSOV Actuator.</li> <li>3. Defective <b>High Gas Pressure</b> switch.</li> </ol>	<ol style="list-style-type: none"> <li>1. Check to ensure that gas pressure at inlet of SSOV is <b>not above</b> 14" W.C. (3.49 kPa).</li> <li>2. If gas supply pressure downstream of SSOV Actuator cannot be lowered to below 3.0" W.C. (747 Pa) using the gas pressure adjustment screw (for NATURAL GAS, see Section 4.3, Step 14, for PROPANE, see Section 4.4 Step 14), the SSOV Actuator may be defective.</li> <li>3. Remove the leads from the <b>High Gas Pressure</b> switch and measure continuity across the common and normally closed terminals with the unit not firing. Replace the switch if it does not show continuity.</li> </ol>



TABLE 7-1. WATER HEATER TROUBLESHOOTING		
FAULT INDICATION	PROBABLE CAUSES	CORRECTIVE ACTION
HIGH WATER TEMP SWITCH OPEN	<ol style="list-style-type: none"> <li>1. Faulty Water temperature switch.</li> <li>2. Incorrect PID settings.</li> <li>3. Faulty shell temperature sensor.</li> <li>4. Unit in MANUAL mode</li> <li>5. Unit setpoint is greater than <b>Over Temperature</b> switch setpoint.</li> <li>6. System flow rate changes are occurring faster than units can respond.</li> </ol>	<ol style="list-style-type: none"> <li>1. Test the temperature switch to insure it trips at its actual water temperature setting.</li> <li>2. Check PID settings against Menu Default settings in Chapter 3. If the settings have been changed, record the current readings then reset them to the default values.</li> <li>3. Using the resistance charts in Appendix C, measure the resistance of Shell sensor and BTU sensor at a known water temperature.</li> <li>4. If unit is in MANUAL mode switch to AUTO mode.</li> <li>5. Check setpoint of unit and setpoint of Temperature switch. Ensure that the temperature switch is set higher than the unit's setpoint.</li> <li>6. If the system is a variable flow system, monitor system flow changes to ensure that the rate of flow change is not faster than what the units can respond to.</li> </ol>
HIGH WATER TEMPERATURE	<ol style="list-style-type: none"> <li>1. See HIGH WATER TEMPERATURE SWITCH OPEN.</li> <li>2. Temp HI Limit setting is too low.</li> </ol>	<ol style="list-style-type: none"> <li>1. See HIGH WATER TEMPERATURE SWITCH OPEN.</li> <li>2. Check Temp HI Limit setting.</li> </ol>
IGN BOARD COMM FAULT	<ol style="list-style-type: none"> <li>1. Communication fault has occurred between the PMC board and Ignition/Stepper (IGST) board.</li> </ol>	<ol style="list-style-type: none"> <li>1. Press <b>CLEAR</b> button and restart unit. If fault persists, contact qualified Service Personnel.</li> </ol>
IGN SWITCH CLOSED DURING PURGE	<ol style="list-style-type: none"> <li>1. Air/Fuel Valve not rotating.</li> <li>2. Defective or shorted switch</li> </ol>	<ol style="list-style-type: none"> <li>1. Start the unit. The Air/Fuel Valve should rotate to the purge (open) position. If the valve does not rotate at all or does not rotate fully open, check the Air/Fuel Valve calibration. If calibration is okay, the problem may be in the Air-Fuel Valve or the C-More Controller. Refer to qualified service personnel</li> <li>2. If the Air/Fuel Valve does rotate to purge, check the <b>Ignition</b> switch for continuity between the N.O. and COM terminals. If the switch shows continuity when not in contact with the cam replace the switch.</li> </ol>

TABLE 7-1. WATER HEATER TROUBLESHOOTING		
FAULT INDICATION	PROBABLE CAUSES	CORRECTIVE ACTION
(continued)	3. Switch wired incorrectly. 4. Defective Power Supply Board or fuse. 5. Defective IGST Board.	3. Check to ensure that the switch is wired correctly (correct wire numbers on the normally open terminals). If the switch is wired correctly, replace the switch. 4. Check <b>DS1</b> & <b>DS2</b> LEDs on Power Supply Board. If they are not steady ON, replace Power Supply Board. 5. Check “Heartbeat” LED <b>DS1</b> and verify it is blinking ON & OFF every second. If not, replace IGST Board.
IGN SWITCH OPEN DURING IGNITION	1. Air/Fuel Valve not rotating to ignition position. 2. Defective <b>Ignition</b> switch. 3. Defective Power Supply Board or fuse. 4. Defective IGST Board.	1. Start the unit. The Air/Fuel Valve should rotate to the purge (open) position, then back to ignition position (towards closed) during the ignition cycle. If the valve does not rotate back to the ignition position, check the Air/Fuel Valve calibration. If calibration is okay, the problem may be in the Air/Fuel Valve or the C-More Controller. Refer fault to qualified service personnel. 2. If the Air/Fuel Valve does rotate to the ignition position, check the ignition position switch for continuity between the N.O. and COM terminals when in contact with the cam. 3. Check <b>DS1</b> & <b>DS2</b> LEDs on Power Supply Board. If they are not steady ON, replace Power Supply Board. 4. Check “Heartbeat” LED <b>DS1</b> and verify it is blinking ON & OFF every second. If not, replace IGST Board.
INTERLOCK OPEN	1. Interlock jumper not installed or removed. 2. Energy Management System does not have unit enabled. 3. Device proving switch hooked to interlocks is not closed.	1. Check for a jumper properly installed across the interlock terminals in the I/O box. 2. If there are two external wires on these terminals check any Energy Management system to see if they have the units disabled (a jumper may be temporarily installed to see if the interlock circuit is functioning). 3. Check that proving switch for any device hooked to the interlock circuit is closing and that the device is operational.

TABLE 7-1. WATER HEATER TROUBLESHOOTING		
FAULT INDICATION	PROBABLE CAUSES	CORRECTIVE ACTION
LINE VOLTAGE OUT OF PHASE	<ol style="list-style-type: none"> <li>1. Line and Neutral switched in AC Power Box.</li> <li>2. Incorrect power supply transformer wiring.</li> </ol>	<ol style="list-style-type: none"> <li>1. Check hot and neutral in AC Power Box to ensure they are not reversed.</li> <li>2. Check transformer wiring, in AC Power Box, against the power box transformer wiring diagram to ensure it is wired correctly.</li> </ol>
LOW GAS PRESSURE	<ol style="list-style-type: none"> <li>1. Incorrect supply gas pressure.</li> <li>2. Defective <b>Low Gas Pressure</b> switch.</li> </ol>	<ol style="list-style-type: none"> <li>1. Measure gas pressure upstream of the SSOV Actuator(s) with the unit firing. For both FM and DBB gas trains, ensure it is between 4.0" W.C. (996 Pa) and 14" W.C. (3.49 kPa) (see Section 2.10.1).</li> <li>2. Measure gas pressure at the <b>Low Gas Pressure</b> switch. If it is greater than 2.6" W.C. (647 Pa), measure continuity across the switch and replace if necessary.</li> </ol>
LOW WATER LEVEL	<ol style="list-style-type: none"> <li>1. Insufficient water level in system.</li> <li>2. Defective water level circuitry.</li> <li>3. Defective water level probe.</li> </ol>	<ol style="list-style-type: none"> <li>1. Check system for sufficient water level.</li> <li>2. Test water level circuitry using the C-More Controller front panel LOW WATER TEST and RESET buttons. Replace water level circuitry if it does not respond.</li> <li>3. Check continuity of probe end to the shell, change probe if there is no continuity.</li> </ol>
MODBUS COMM FAULT	Unit not seeing information from Modbus network.	Check network connections. If fault persists, contact qualified Service Personnel.
PRG SWITCH CLOSED DURING IGNITION	<ol style="list-style-type: none"> <li>1. A/F Valve rotated open to purge and did not rotate to ignition position.</li> <li>2. Defective or shorted switch.</li> </ol>	<ol style="list-style-type: none"> <li>1. Start the unit. The Air/Fuel Valve should rotate to the purge (open) position, then back to ignition position (towards closed) during the ignition cycle. If the valve does not rotate back to the ignition position, check the Air/Fuel Valve calibration. If calibration is okay, the problem may be in the Air/Fuel Valve or the C-More Controller. Refer fault to qualified service personnel.</li> <li>2. If the Air/Fuel Valve does rotate to the ignition position, check the purge switch for continuity between the N.O. and COM terminals. If the switch shows continuity when not in contact with the cam, check to ensure that the switch is wired correctly (correct wire numbers on the normally open terminals).</li> </ol>

TABLE 7-1. WATER HEATER TROUBLESHOOTING		
FAULT INDICATION	PROBABLE CAUSES	CORRECTIVE ACTION
(continued)	3. Switch wired incorrectly. 4. Defective Power Supply Board or fuse. 5. Defective IGST Board.	3. If the switch is wired correctly, replace the switch. 4. Check <b>DS1</b> & <b>DS2</b> LEDs on Power Supply Board. If they are not steady ON, replace Power Supply Board. 5. Check “Heartbeat” LED DS1 and verify it is blinking ON & OFF every second. If not, replace IGST Board.
PRG SWITCH OPEN DURING PURGE	1. Defective purge switch. 2. No voltage present at switch. 3. Switch wired incorrectly. 4. Defective Power Supply Board or fuse. 5. Defective IGST Board.	1. If the air-fuel valve does rotate, check purge switch for continuity when closing. Replace switch if continuity does not exist. 2. Measure for 24 VAC from each side of the switch to ground. If 24VAC is not present, refer fault to qualified service personnel. 3. Check to ensure that the switch is wired correctly (correct wire numbers on the normally open terminals). 4. Check <b>DS1</b> & <b>DS2</b> LEDs on Power Supply Board. If they are not steady ON, replace Power Supply Board. 5. Check “Heartbeat” LED <b>DS1</b> and verify it is blinking ON & OFF every second. If not, replace IGST Board.
OUTDOOR TEMP SENSOR FAULT	1. Loose or broken wiring. 2. Defective Sensor. 3. Incorrect Sensor.	1. Inspect Outdoor Temperature sensor for loose or broken wiring. 2. Check resistance of sensor to ensure it is within specification. 3. Ensure that the correct sensor is installed.
RECIRC PUMP FAILURE	1. Internal recirculation pump failed.	1. Replace recirculation pump.
REMOTE SETPT SIGNAL FAULT	1. Remote setpoint signal not present: not yet installed. Wrong polarity. Signal defective at source. Broken or loose wiring. 2. Signal is not isolated (floating) if 4 to 20 mA. 3. C-More Controller signal type selection switches not set for correct signal type (voltage or current).	1. Check I/O Box to ensure signal is hooked up. Hook up if not installed. If installed, check polarity. Measure signal level. Check continuity of wiring between source and unit. 2. Check signal at source to ensure it is isolated. 3. Check <b>DIP</b> switch on PMC board to ensure it is set correctly for the type of signal being sent. Check control signal type set in Configuration Menu.

TABLE 7-1. WATER HEATER TROUBLESHOOTING		
FAULT INDICATION	PROBABLE CAUSES	CORRECTIVE ACTION
RESIDUAL FLAME	<ol style="list-style-type: none"> <li>1. SSOV not fully closed.</li> <li>2. Defective Flame Detector.</li> </ol>	<ol style="list-style-type: none"> <li>1. Check open/close indicator window of Safety Shut-Off Valve (SSOV) and ensure that the SSOV is fully closed. If not fully closed, replace the valve and or actuator. Close the 1" Gas Shut-Off Valve downstream of SSOV (Figure 7-1). Install a manometer or gauge at the leak detection port between the SSOV and Gas Shut Off Valve. If a gas pressure reading is observed replace the SSOV Valve and/or Actuator.</li> <li>2. Replace Flame Detector.</li> </ol>
SSOV FAULT DURING PURGE	See SSOV SWITCH OPEN	
SSOV FAULT DURING RUN	SSOV switch closed for 15 seconds during run.	Replace or adjust micro switch in SSOV actuator. If fault persists, replace actuator.
SSOV RELAY FAILURE	<ol style="list-style-type: none"> <li>1. SSOV relay failed on IGST board.</li> <li>2. Floating Neutral.</li> <li>3. Hot and Neutral reversed at SSOV.</li> </ol>	<ol style="list-style-type: none"> <li>1. Press <b>CLEAR</b> button and restart unit. If fault persists, replace Ignition/Stepper (IGST) Board.</li> <li>2. The Neutral and Earth Ground are not connected at the source and therefore there is a voltage measured between the two. This measurement should be near zero or no more than a few millivolts.</li> <li>3. Check SSOV power wiring.</li> </ol>
SSOV SWITCH OPEN	<ol style="list-style-type: none"> <li>1. Actuator not allowing for full closure of gas valve.</li> <li>2. SSOV powered when it should not be.</li> <li>3. Defective switch or Actuator.</li> <li>4. Incorrectly wired switch.</li> </ol>	<ol style="list-style-type: none"> <li>1. Observe operation of the Safety Shut-Off Valve (SSOV) through indicator on the Valve actuator and ensure that the valve is fully and not partially closing.</li> <li>2. If the SSOV never closes, it may be powered continuously. Close the gas supply and remove power from the unit. Refer fault to qualified service personnel.</li> <li>3. Remove the electrical cover from the SSOV and check switch continuity. If the switch does not show continuity with the gas valve closed, either adjust or replace the switch or actuator.</li> <li>4. Ensure that the SSOV Proof of Closure switch is correctly wired.</li> </ol>

TABLE 7-1. WATER HEATER TROUBLESHOOTING		
FAULT INDICATION	PROBABLE CAUSES	CORRECTIVE ACTION
STEPPER MOTOR FAILURE	<ol style="list-style-type: none"> <li>1. Air/Fuel Valve out of calibration.</li> <li>2. Air/Fuel Valve unplugged.</li> <li>3. Loose wiring connection to the stepper motor.</li> <li>4. Defective Air/Fuel Valve stepper motor.</li> <li>5. Defective Power Supply Board or fuse.</li> <li>6. Defective IGST Board.</li> </ol>	<ol style="list-style-type: none"> <li>1. Perform Stepper Test per GF-112 (section 6.3.5) to ensure stepper motor rotates properly from 0% (fully closed) to 100% (fully open) positions. Verify VALVE POSITION bargraph and dial on the Air/Fuel Valve track each other to indicate proper operation. If operation is not correct, perform the Stepper Feedback Calibration (GF-112, section 6.2.1).</li> <li>2. Check that the Air/Fuel Valve is connected to the C-More Controller.</li> <li>3. Inspect for loose connections between the Air/Fuel Valve motor and the wiring harness.</li> <li>4. Replace stepper motor.</li> <li>5. Check <b>DS1</b> &amp; <b>DS2</b> LEDs on Power Supply Board. If they are not steady ON, replace Power Supply Board.</li> <li>6. Check “Heartbeat” LED <b>DS1</b> and verify it is blinking ON &amp; OFF every second. If not, replace IGST Board.</li> </ol>
WARNING EXHAUST TEMP HIGH (Flashing WARNING)	<ol style="list-style-type: none"> <li>1. Poor combustion calibration.</li> <li>2. Heat exchanger has scale.</li> </ol>	<ol style="list-style-type: none"> <li>1. Check combustion calibration using procedures in Chapter 4.</li> <li>2. Clean heat exchanger using procedures in Chapter 6.</li> </ol>

## 7.2 ADDITIONAL FAULTS WITHOUT SPECIFIC FAULT MESSAGES

Refer to Table 7-2 to troubleshoot faults which may occur without a specific fault message being displayed.

<b>TABLE 7-2. WATER HEATER TROUBLESHOOTING WITH NO FAULT MESSAGE DISPLAYED</b>		
<b>OBSERVED INCIDENT</b>	<b>PROBABLE CAUSES</b>	<b>CORRECTIVE ACTION</b>
Fluctuating Gas Pressure	1. Gas pressure going into unit is fluctuating.	1. Stabilize gas pressure going into unit. If necessary, troubleshoot Building Supply Regulator.
Air/Fuel Valve “hunting” at the 80% Valve Position	1. IGST and Power Supply Boards in C-More Controller are outdated.	1. Check to ensure that the IGST and Power Supply Boards are Rev. E or higher.



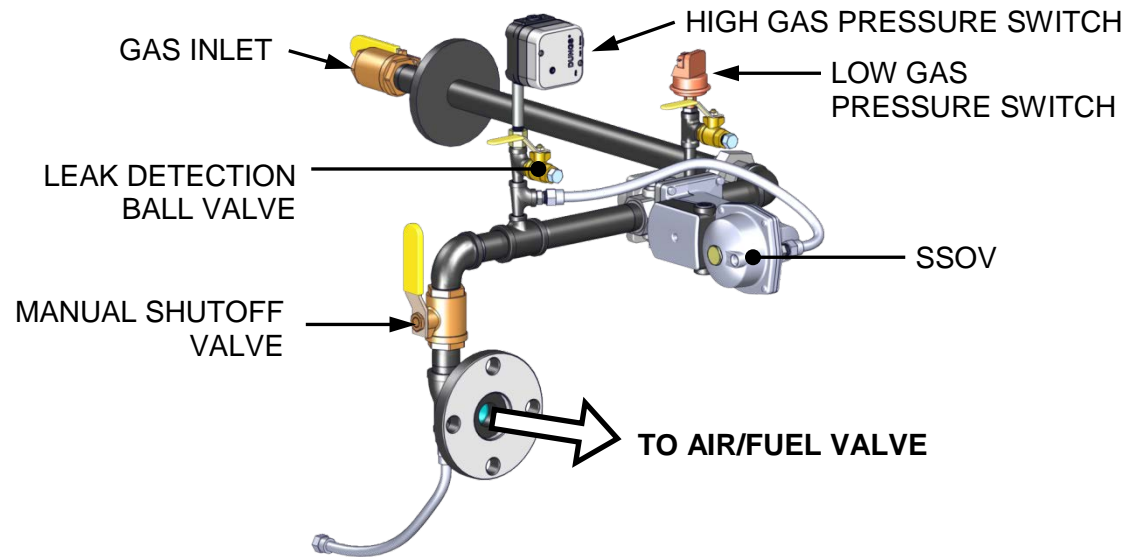


Figure 7-1. Innovation 600/800/1060 Gas Train Component Locations (P/N 22122 Shown)

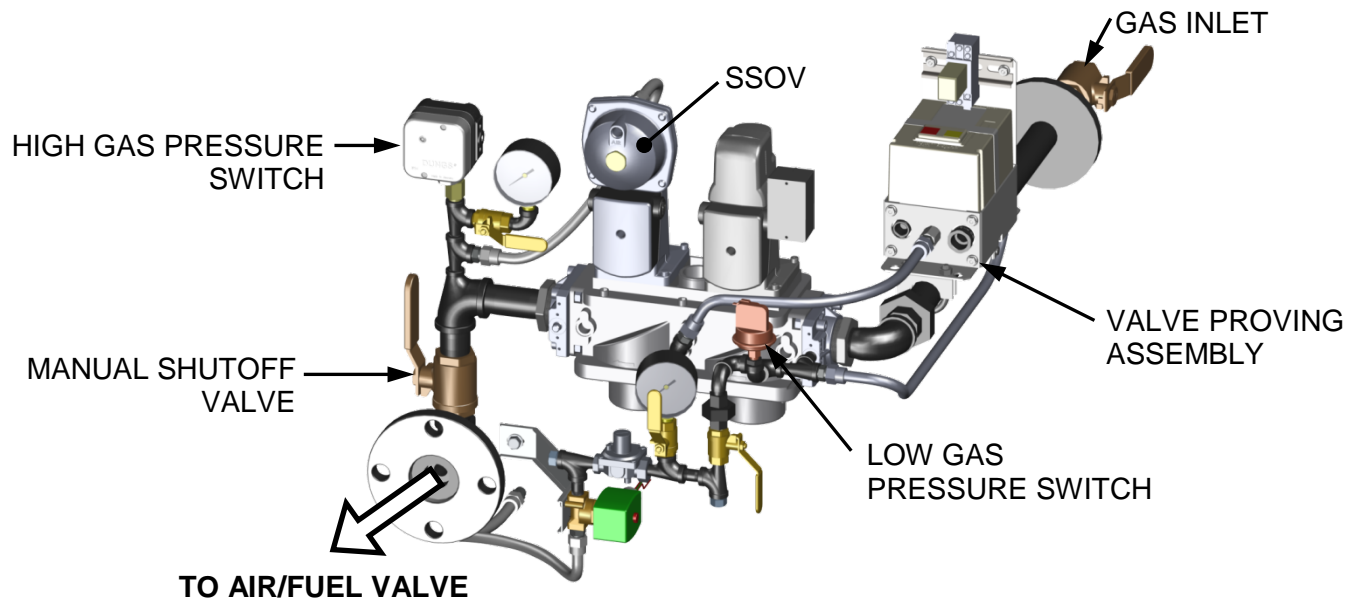
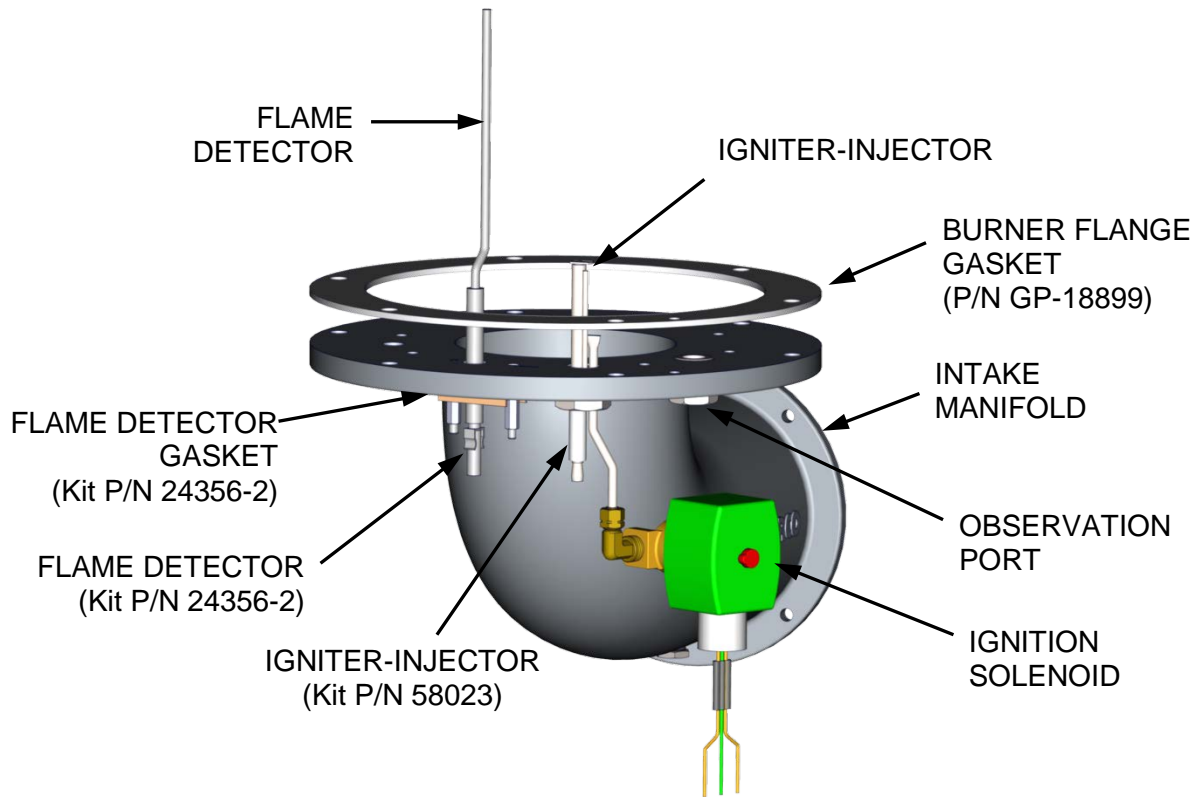
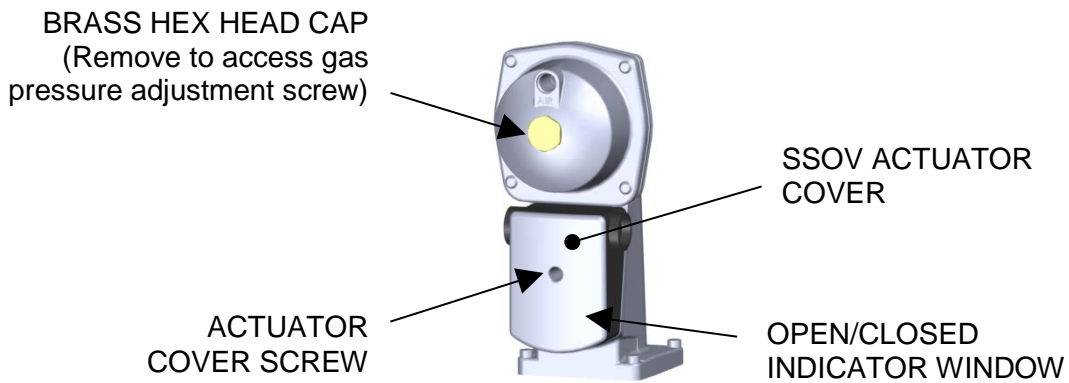


Figure 7-2. Innovation 1400 Gas Train Component Locations (P/N 22182-1 Shown)



**Figure 7-3. Intake Manifold**



**Figure 7-4. SSOV Actuator with Gas Pressure Adjustment**

(This Page Is Intentionally Blank)

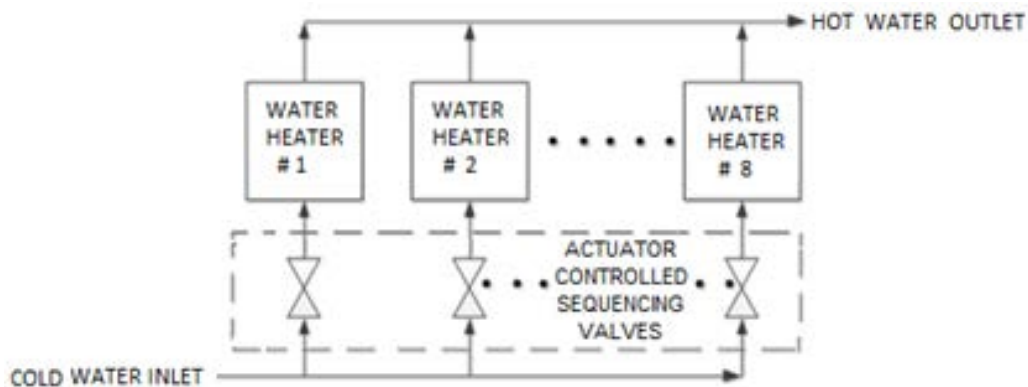
# CHAPTER 8. WATER HEATER MANAGEMENT

**NOTE:**  
 Some of the descriptions and procedures provided in this Chapter may duplicate information provided in previous Chapters of this manual. This is being done to minimize referencing back to these descriptions and procedures and organize all WHM related information into a single Chapter. It is assumed that the user is familiar with the basic C-More Menu processing procedures used throughout this manual.

The On-Board-Water-Heater Management system II (WHM II) is an integrated C-MORE feature designed to stage and coordinate multiple AERCO Innovation water heaters while maximizing operational efficiency. The WHM software code resides in each C-More that is part of the system. The WHMII can control up to eight (8) water heaters in parallel. Each water heater controlled by the WHM must be equipped with an Actuator-Controlled Sequencing Valve (P/N **92123**). These valves are installed on the cold water inlet on each water heater being controlled by the WHM (see Figure 8-1).

## 8.1 GENERAL DESCRIPTION

The C-More Water Heater Management System (WHM) is designed to ensure that all water heaters in the system operate at maximum efficiency. This is accomplished by monitoring the Air/Fuel Valve position (VP) of all water heaters that have their sequencing valves open. Units with open sequencing valves are called enabled units. Units with closed sequencing valves are called disabled units. Units which are unable to function, due to a fault or user intervention, are called offline units. When there is minimal or no demand for hot water, the sequencing valve for one unit will be open. As system load increases, the WHM will open the sequencing valves on additional heaters. A simplified block diagram of multiple water heaters connected to a WHM is shown in Figure 8-1.



**Figure 8-1. Simplified Block Diagram - Water Heater Management (WHM)**

### 8.2 WHM PRINCIPLES OF OPERATION

The WHM system communicates with the plant water heaters via a RS485 network utilizing Modbus RTU protocol (8 bit, 9600 baud, no parity). All Modbus networks are implemented using a “Manager” / “Client” scenario where only one device, the Manager, can initiate a communication sequence. All other C-More equipped units on the network are called Clients. However, since the WHM software code resides in each C-More that is part of the system, any one of the C-Mores can be selected to control the system.

The controlling Manager monitors the Air/Fuel Valve position (VP) of all enabled units. When this valve position (% open) exceeds a user-selectable limit (WHM Nxt On VP), the WHM will open the sequencing valve of another water heater in the system. Conversely, when the valve positions of all enabled units have dropped below a different user-selectable limit (WHM Nxt Off VP) threshold, the WHM will close the sequencing valve on a unit. The philosophy behind this approach is to maintain the fire rates (Air/Fuel Valve % open) at a level that maximizes heater efficiency.

In addition to collecting Air/Fuel Valve position data, the controlling Manager also monitors the total accumulated operating time for each unit on the system and attempts to balance the system so that all units operate for approximately the same number of hours.

### 8.3 NEW AERCO WHM FEATURES

The following sections describe new Water heater Management features.

#### 8.3.1 Valve Feedback

The Valve Feedback feature is designed to confirm that the Neptronic Valve has successfully executed either a Valve-Open or Valve-Close command from the C-More.

The Valve Feedback signal from the Neptronic Valve is connected to the C-More via the I/O box. When the C-More issues either a Valve-Open or Valve-Close command to the valve, the Valve Feedback signal is monitored to confirm that the Neptronic Valve has successfully opened or closed. If there is a mismatch between the Valve Feedback signal and the Valve-Open or Valve-Close command for a period of time exceeding the value entered in “Valve Fdbk timer” a fault is invoked.

This feature can be enabled or disabled in the “Valve Feedback” menu item.

#### 8.3.2 Valve Supervisor

This feature periodically monitors the Neptronic valve status (On or Off) and compares it to the Valve command. If there is a mismatch, a fault is displayed and the unit will react as follows:

1. If the Valve is Stuck Open, it displays the **VALVE STUCK OPEN** fault message but continue with the unit operation (do not shut the unit down).
2. If the Valve is Stuck Closed, it shuts down the unit and displays the **VALVE STUCK CLOSED** fault message.

#### 8.3.3 Valve Control

The Valve Control logic has been redesigned to assure proper valve operation. Critical valve positioning (On or Off) is assured by the development of two independent valve control functions, with one function monitoring the results of the other.

### 8.3.4 Modbus Header Sensor

This optional feature allows users to monitor the combined system Outlet Temperature or the system Tank temperature via Modbus. This feature requires a Modbus Temperature sensor Module to read and transmit the temperature to the Manager unit. This feature also allows a user to view the temperature in either °F or °C.

Each unit has the following Modbus Header Temp points available:

- MB Head Temp En: This menu allows the user to enable/disable the Modbus Header Temp.
- Header Temp Addr: A user must enter Modbus module address. Default is 240.
- Header Tmp Point: A user must enter Modbus register point. Default is 14.
- WHM Header Temp: This menu item displays the Temperature.

### 8.3.5 Automatic Temperature Sensor Calibration

This feature allows the user to automatically calibrate the temperature sensors to achieve optimal system performance and efficiency. This feature requires an AERCO Temperature Calibration dongle (fixed resistor set) and a password level to access the calibration menu.

Following are the steps required to Auto-calibrate the temperature sensors.

1. Disable the unit.
2. Remove the P1 harness from the back of the C-More box and insert the dongle in its place.
3. In the “Cal Temp Sensor” item of the calibration menu, change the menu entry to “Start” and hit the “Enter” Key.
4. This feature will only calibrate Inlet Water Temp, FFWD Water Temp, Exhaust Air temp and Outlet Water Temp.
5. In this version, this feature will not calibrate the Inlet Air temp and Outdoor Air temp sensors. Once the calibration has been completed, remove the dongle and inset the harness P1 back into the C-More.

### 8.3.6 Manual Mode Password Required

In order to prevent unauthorized or inadvertent setting the MANUAL mode of operation, entering a valid password is required to set the C-More in MANUAL mode. Any level password will enable the MANUAL mode button. MANUAL mode is a temporary run state and switches back to Automatic mode once the password expires after 1 hour of menu inactivity.

### 8.3.7 WHM Auto Mstr

Password Level 2 (6817) or greater must be entered in order to access the **WHM Auto Mstr** menu option. This item is used to enable (yes) or disable (no) an Automatic Manager switch-over function. When enabled (yes), the WHM will automatically select a new Manager if the current Manager fails or loses power. This option is used with the WHM Auto Timer option described in the following section. The default for this option is No (disabled).

### 8.3.8 Run Hours and Run Cycles

Run hours and run cycles are monitored to select the lead unit and lag unit (next on unit) in WHM. In the event a C-More or PMC board is exchanged in the field, this feature will allow the user to increase but not decrease the run hours or run cycles. Once a user hits enter, the changes made will be permanent and this feature will not allow changing to the previous value.

Only AERCO personnel are permitted to change this menu item. To increase the Run Hours/Cycles, go the “Run Cycles” or “Run Hours” items in the Diagnostic menu.

### 8.3.9 High Temperature Governor

The High Temperature Governor is a feature that aggressively prevents the Outlet Temperature from exceeding the “High Temp Limit”. The High Temperature Governor is independent of the system PID and Feed-forward control methodology and independently modulates the Valve Position (Fire Rate) if the Outlet Temperature dangerously approaches the “High Temp Limit” setting.

This feature has 5 separate temperature bands for more precise control.

This feature is enabled or disabled by the **TEMP GOV ENABLE** item in the Tuning Menu. See Table A-4 in Appendix A for a description of this item and the 5 governor items.

## 8.4 WHM STATUS DISPLAYS

The following WHMS status information will be displayed on two line VFD Display on the front of the C-More to inform the user of critical WHMS real-time operating conditions:

#### **WHMS Manager Identification:**

Whenever a WHMS Heater is defined as the MANAGER, the large, 3 digit display of the front for the C-More will continuously blink and display the OUTLET TEMPERATURE.

#### **Manager Display:**

The Heater defined as the MANAGER will display the flowing status information on the two line VFD display:

- MANAGER-DISABLED** – *The Manager has been disabled and is not available*
- MANAGER-STANDBY** – *The Manager is “Cycled Off” and is available to be lit off*
- MANAGER-IGNITED** – *The Manager is ignited*

#### **Client Displays:**

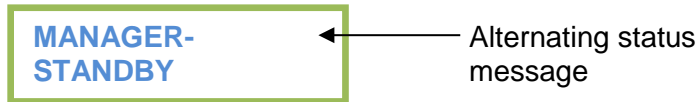
The Heaters defined as the CLIENT units will display the flowing status information on the two line VFD display:

- CLIENT-DISABLED** – *The Client has been disabled and is not available*
- CLIENT-STANDBY** – *The Client is “Cycled Off” and is available to be lit off*
- CLIENT-IGNITED** – *The Client is ignited*

Example:

If a Manager is enabled and in Standby mode, the C-More display will show as follows:





## 8.5 WATER HEATER MANAGEMENT ALTERNATING STATUS DISPLAYS

### Manager/Client Status Displays:

On both WHMS Manager and Client heaters, the following status information will alternate, and be displayed on the two line VFD display on the front of the C-More.

- |                         |                                                                             |
|-------------------------|-----------------------------------------------------------------------------|
| <b>FAILSAFE ACTIVE</b>  | – <i>The Client Failsafe Mode has been activated</i>                        |
| <b>All Heaters On</b>   | – <i>All available heaters are ignited</i>                                  |
| <b>All Heaters Off</b>  | – <i>All available heaters are off</i>                                      |
| <b>Enabling First</b>   | – <i>The first heater is allowed to ignite and its valve is opened</i>      |
| <b>Enabling Next</b>    | – <i>The next heater is allowed to ignite and its valve is opened</i>       |
| <b>Wtr Htr Inactive</b> | – <i>This Client unit is inactive, its valve is closed and can't ignite</i> |
| <b>Wtr Heatr Active</b> | – <i>This Client unit is active, its valve is opened and it can ignite</i>  |
| <b>REMOTE SIG FAULT</b> | – <i>Remote signal fault</i>                                                |
| <b>WHMS FAILSAFE</b>    | – <i>WHMS is in Failsafe Mode</i>                                           |

Example: If all available heaters are turned off, the C-More display will alternate the display above (MANAGER-STANDBY) with the All Heaters Off status message as follows:



## 8.6 WHM MENU

The WHM Menu in each C-More can only be viewed when the **Unit Type** option in the Configuration Menu is set to **Innovation WH**. Most of the options in this menu are preset at the factory and cannot be altered by the user.

A full description of each item appears in Section 8.7 – WHM Menu Item Descriptions.

### NOTES

Some of the WHM menu items appear only if they are enabled, either in the WHM Menu or by a specific menu item. For example, item 31, WHM Header Temp, does not appear unless item 30, MB Head Temp En = Enable.

In addition to the WHM Menu items listed in Table 8-1, the Setup Menu contains a **Comm Address** option which must be entered for each unit to enable WHM control of the system.

TABLE 8-1. WHM Menu				
Item	Menu Item Display	Available Choices or Limits		Default
		Minimum	Maximum	
1	WHM Mode	Off, WHM Client, WHM Manager		Off
2	WHM Setpoint	40°F (4.4°C)	190°F (87.8°C)	130°F (54.4°C)
3	WHM Nxt On VP	16%	100%	55%
4	WHM Nxt Off VP	16%	100%	25%
5	Lead/Lag Hours	4	225	72
6	WHM Upd Timer	0	9999	0
7	Setpoint Setback	Enable, Disable		Disable
8	Setback Setpoint	60°F (15.6°C)	195°F (90.6°C)	130°F (54.4°C)
9	Setback Start	12:00am	11:59pm	12:00am
10	Setback End	12:00am	11:59pm	12:00am
11	WHM Auto Mstr *	Yes or No		No
12	WHM Auto Timer *	10 sec.	120 sec.	30 sec.
13	WHM min addr	1	128	1
14	WHM max addr	1	8	8
15	SSD address	0	250	0
16	SSD Temp Format	Degrees or Points		Degrees
17	1 Valve Status 8	0	0	0
18	1 Comm Errors 8	0	0	0
19	WHM On Delay	30 sec	300 sec	60 sec

<b>TABLE 8-1. WHM Menu</b>				
<b>Item</b>	<b>Menu Item Display</b>	<b>Available Choices or Limits</b>		<b>Default</b>
		<b>Minimum</b>	<b>Maximum</b>	
20	WHM Off Delay	30 sec	300 sec	60 sec
21	Over WHM Under	0	0	0
22	WHM Min Units	1	8	1
23	WHM Warmup Time	0	300 sec	30 sec
24	WHM On Timeout	15 Sec	300 Sec	30 Sec
25	WHM Valve State	0	1	0
26	Valve Override	Auto, Open or Closed		Auto
27	Valve Feedback	Enable or Disable		Disable
28	Valve Fdbk timer	30 sec	240 sec	60 sec
29	ValveFdbk Status	Close	Open	Fdbk state
30	MB Head Temp En	Enable or Disable		Disable
31	WHM Header Temp	0	0	Header Temp
32	Mdbus Temp Units	°F or °C		°F
33	Header Temp Addr	0	255	240
34	Header Tmp Point	0	255	14
35	MB Outdr Sens En	Enable or Disable		Disable
36	WHM Outdr Temp	0	0	Outdr Temp
37	Outdoor Tmp Addr	0	255	240
38	Outdoor Tmp Pnt	0	255	15
39	Err Threshold	1	9	5
40	Comm Address	0	127	0
41	1 WHM Units 8 (for 1 – 8 units)	- = Off Line * = Not Available (fault, etc.) 0 = Off 1 = On, A = Lead On		a = Lead Off B = Lag On b = Lag Off S = Setpoint Limit Active

**\* NOTE**

The Level 2 Password (6817) in the Setup Menu must be entered to view or change the WHM Auto Mstr and WHM Auto Timer options (items 11 and 12, above).

## 8.7 WHM MENU ITEM DESCRIPTIONS

The required settings for WHM Menu items will vary depending on the number of units connected to the Modbus network and required setpoint and operating conditions to be maintained on the network. Set the menu options in accordance with the descriptions provided in Table 8-2, below.

### NOTE

It is recommended that the WHM Menu settings be performed first on the WHM Manager. This will simplify the number of required entries since most of the settings will be “pushed” to the appropriate Clients.

**TABLE 8-2: Water Heater Management Menu Item Descriptions**

See Section 8-6 for a range of choices and the default values.

ITEM	MENU LEVEL & OPTION	DESCRIPTION
1	WHM Mode	This menu option enables/disables the WHM mode and sets the unit to function as a WHM Client or WHM Manager. Set the WHM mode option to <b>WHM Manager</b> for the controlling Manager and to <b>WHM Client</b> for all other units on the Modbus network.
2	WHM Setpoint	This is the temperature (°F or °C) that each unit in the WHM system is trying to control to.
3	WHM Nxt On VP (See NOTE below)	This is the Next <b>On</b> A/F Valve position (%) for the system. When all enabled water heaters have a fire rate greater than this value, it is time to enable another water heater, if one is available. This value should always be greater than the Next Off A/F Valve, and there should be a reasonable spread between the 2 values.
4	WHM Nxt Off VP (See NOTE below)	This is the Next <b>Off</b> A/F Valve position (%) for the system. When all enabled water heaters have a A/F Valve position less than this value, it is time to shut down another water heater, if one is available. This value should always be less than the Next On A/F Valve position, and there should be a reasonable spread between the 2 values.
5	Lead/Lag Hours	This menu option is designed to spread the total number of run hours accumulated on all units in the system so that each unit has approximately the same number of run hours.
6	WHM Upld Timer	Sets the time between successive WHM Heartbeat OnAER data transmissions.
7	Setpoint Setback	Enables/Disables the Setpoint Setback feature which allows for the substitution of an alternate Setpoint setting during certain time periods of the day. The alternate Setpoint is entered into the <b>Setback Setpoint</b> item and the time is entered in the Setback <b>Start</b> and <b>Setback End</b> items.

**TABLE 8-2: Water Heater Management Menu Item Descriptions**

See Section 8-6 for a range of choices and the default values.

ITEM	MENU LEVEL & OPTION	DESCRIPTION
8	Setback Setpoint	This menu item specifies the setpoint temperature (°F or °C) that the WHM system will maintain during time periods of low DHW demand.
9 & 10	Setback Start: Setback End:	These two menu items specify the start and end times that the Setback Setpoint will be in effect. (12:00am – 11:59pm)
11	WHM Auto Mstr	Password Level 2 (6817) must be entered in order to access the WHM Auto Mstr menu option. This item Enables (Yes) or Disables (No) an Automatic WHM Manager Switch-Over function. When enabled (Yes) the WHM will automatically select a new Manager if the current Manager fails or loses power. This option is used with the WHM Auto Timer option, described in the following section.
12	WHM Auto Timer	Password Level 2 (6817) must be entered in order to access the WHM Auto Timer menu option. When the WHM Auto Mstr option is set to Yes (Enabled), the WHM Auto Timer option allows the user to select the elapsed time interval between failure of the WHM Manager and switch-over to a new WHM Manager.
13	WHM Min Addr	Set the minimum address of the heaters to be controlled by the Manager. The <b>WHM Min Addr</b> and <b>WHM Max Addr</b> must differ by no more than 7.
14	WHM Max Addr	Set the maximum address of the heaters to be controlled by the Manager. The <b>WHM Min Addr</b> and <b>WHM Max Addr</b> must differ by no more than 7.
15	SSD Address	The Modbus Address of the SSD Device (ProtoNode). Set this address to 247 if the WHM system is being monitored by a ProtoNode with Client-Client (SSD) programming. Set to zero (0) if no ProtoNode is installed.
16	SSD Temp Format	SSD temp values can be accessed in Degrees or Points
17	1 Valve Status 8	Displays the valve status of all the units. 0= valve closed 1= valve open 2= valve stuck closed 3= valve stuck open
18	1 Comm Errors 8	Display Comm Errors of all the units.

**TABLE 8-2: Water Heater Management Menu Item Descriptions**

See Section 8-6 for a range of choices and the default values.

ITEM	MENU LEVEL & OPTION	DESCRIPTION
19	WHM On Delay	Specifies the WHM On and Off time delays associated with the Next ON VP and Next OFF VP menu options. Therefore, if the Next ON VP or Next OFF VP is at its preset Valve Position (%) for the specified Delay period, another heater will be turned ON or OFF. This is done to prevent cycling units on and off during short changes in load.
20	WHM off Delay	
21	Over WHM Under	This value is a Factory debugging tool.
22	WHM Min Units	Specifies the Minimum number of units required to be “on” or “active”.
23	WHM Warmup Time	Specifies the time a valve will remain closed when turning on a unit in order to assure that we do not release cold water into the building. When turning on a unit, the valve will open when either the Warmup Timer times out or the FeedForward Temperature reaches Setpoint.
24	WHM On Timeout	Specifies the time the WHM Manager waits for a Client unit to turn On.
25	WHM Valve State	Displays the status of the WHM Sequencing Valve. (1 = ON, 0 = OFF)
26	Valve Override	Valve Override allows the user to manually control an Isolation Valve as follows: <ul style="list-style-type: none"> <li>• <b>Off</b>– Valve Override is disabled and WHM will automatically control the Isolation Valve.</li> <li>• <b>Open</b> – Valve Override is enabled and the Isolation Valve is Opened.</li> </ul> <b>Note!</b> The valve will remain opened as long as the Valve Override feature is set to Open. Care must be taken to insure that this mode is turned Off during normal WHM operation. <ul style="list-style-type: none"> <li>• <b>Closed</b> – Valve</li> </ul>
27	Valve Feedback	Enable or disable the Valve feedback feature
28	Valve Fdbk timer	The time allotted the Valve to Open or Close once a command has been issued before invoking a fault.
29	ValveFdbk Status	Displays a Valve status of the unit: 0= valve closed 1= valve open 2= valve stuck closed 3= valve stuck open
30	MB Head Temp En	Enable or disable the Modbus Header Temp sensor
31	WHM Header Temp	Display the Header Sensor
32	Mdbus Temp Units	Modbus temp unit format (°F or °C)

**TABLE 8-2: Water Heater Management Menu Item Descriptions**

See Section 8-6 for a range of choices and the default values.

ITEM	MENU LEVEL & OPTION	DESCRIPTION																		
33	Header Temp Addr	Modbus header Temp address.																		
34	Header Tmp Point	Modbus point to read the header temp register point																		
35	MB Outdr Sens En	Enable or disable the Modbus Outdoor Temp sensor																		
36	WHM Outdr Temp	Display Outdoor temp value																		
37	Outdoor Tmp Addr	Modbus Outdoor Temp address																		
38	Outdoor Tmp Pnt	Modbus point to read the Outdoor Temp register point																		
39	Err Threshold	Max allowable comm errors before a comm. fault is invoked.																		
40	Comm Address	Set the Comm Address for the unit (This option also available in setup menu)																		
41	1 WHM Units 8	<p>This menu item shows the current status for each unit controlled by WHM (8 max.). The characters displayed are defined as:</p> <table style="width: 100%; border: none;"> <tr> <td style="width: 50%;">- = Off Line</td> <td style="width: 50%;">a = Lead Off</td> </tr> <tr> <td>* = Not Available (fault, etc.)</td> <td>B = Lag On</td> </tr> <tr> <td>0 = Off</td> <td>b = Lag Off</td> </tr> <tr> <td>1 = On,</td> <td>S = Setpoint Limit Active</td> </tr> <tr> <td>A = Lead On</td> <td></td> </tr> </table> <p>The following example shows the status of 5 units being controlled by WHM where:</p> <p>Unit 1 &amp; 3 are <b>On</b>                      Unit 2 is <b>Off</b>                      Unit 4 is <b>Not Available</b>                      Unit 5 is <b>Lead On</b>                      Unit 6 is <b>Lag Off</b></p> <p>1 WHM Units 8</p> <table border="1" style="width: 100%; border-collapse: collapse; text-align: center;"> <tr> <td style="width: 12.5%;">1</td> <td style="width: 12.5%;">0</td> <td style="width: 12.5%;">1</td> <td style="width: 12.5%;">*</td> <td style="width: 12.5%;">A</td> <td style="width: 12.5%;">b</td> <td style="width: 12.5%;"></td> <td style="width: 12.5%;"></td> </tr> </table>	- = Off Line	a = Lead Off	* = Not Available (fault, etc.)	B = Lag On	0 = Off	b = Lag Off	1 = On,	S = Setpoint Limit Active	A = Lead On		1	0	1	*	A	b		
- = Off Line	a = Lead Off																			
* = Not Available (fault, etc.)	B = Lag On																			
0 = Off	b = Lag Off																			
1 = On,	S = Setpoint Limit Active																			
A = Lead On																				
1	0	1	*	A	b															

**NOTE:**

The **WHM Nxt On VP** and **WHM Nxt Off VP** options (Items 3 and 4) will determine how tight a range the temperature is controlled in, and how quickly the system responds to a change in load. A narrow difference between Nxt On VP and WHM Nxt Off VP will make the system more responsive to load changes.



### 8.8 WHM HARDWARE INSTALLATION & SET-UP INSTRUCTIONS

The following sections provide the basic installation and set-up instructions for implementing a Water Heater Management System (WHM) to control up to eight (8) AERCO Innovation Water Heaters. Some of the descriptions and procedures included in Chapter 2 are repeated here to avoid unnecessary referencing.

#### 8.8.1 Installation Notes

AERCO requires a WHM sequencing valve in multi-unit Innovation configurations. When WHM is employed, Modbus communication with BAS requires a ProtoNode SSD (Client-Client Device).

If you are installing a WHM system that also includes a ProtoNode SSD, you **must** adhere to the procedure listed below. Failure to complete these steps can result in the failure of the WHM system.

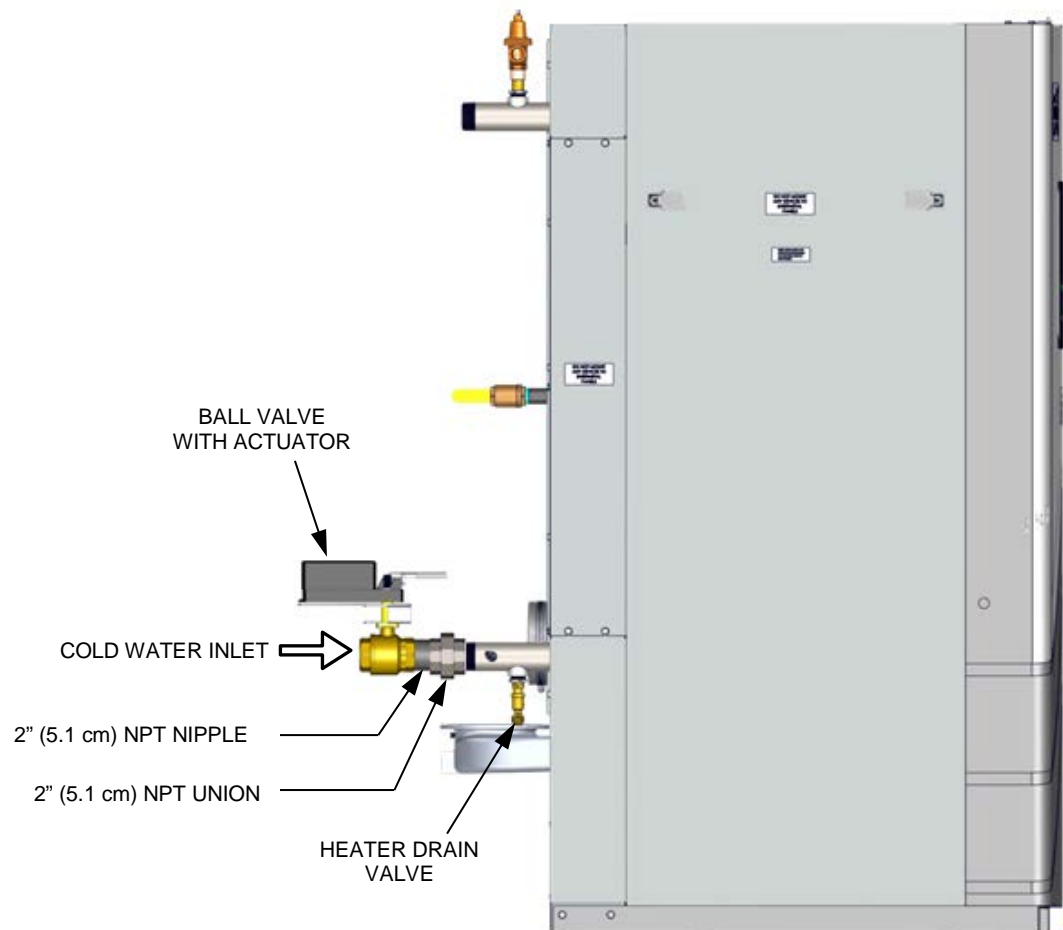
- a) Do **NOT** install the ProtoNode Device at the outset of the installation. If the ProtoNode Device is already installed, you must physically disconnect it from the Modbus network in I/O board.
- b) Make sure that the Modbus load and bias resistors are properly configured for the system to operate without the ProtoNode installed.
- c) Temporarily set the WHM system for Constant Setpoint mode of operation (see below).
- d) Turn on and completely test the installation to verify that it is operating proper.
- e) Once the installation is working properly as a WHM system, install the ProtoNode Device.
- f) Make sure that the Modbus load and bias resistors are properly configured for the system to operate with the ProtoNode installed.
- g) Set the WHM system for desired mode of operation (Setpoint mode).
- h) Test the system completely with the ProtoNode installed.

### 8.8.2 Hardware Installation

All Innovation Water Heaters which will be controlled by a WHM Manager must be equipped with an actuator-controlled sequencing valve (P/N **92123**). If this valve is not already installed on the cold water inlet, proceed as follows:

#### WHM Hardware Installation

1. Remove the sequencing valve from its stowed location.
2. Refer to Figure 8-2 and attach the valve to the cold water inlet of the unit (shown in Figure 8-2, below) using the pipe union and nipple provided.
3. Ensure that the valve is positioned with the actuator enclosure position as shown in Figure 8-2.
4. AERCO recommends that another pipe nipple and union be attached to the valve inlet prior to connecting the cold water supply piping.
5. Tighten all pipe connections after the sequencing valve is properly positioned.
6. Connect the 4-pin Molex connector on the sequencing valve to the mating connector on the Innovation harness at the rear of the unit.
7. This completes the sequencing valve installation.



**Figure 8-2. Innovation Water Heater Equipped With Sequencing Valve**

### 8.8.3 WHM Modbus Network Wiring

As previously mentioned, all units being controlled by the WHM will be connected to a RS485 Modbus Network. All Modbus networks are wired in a daisy-chain configuration using a Manager/Client scenario as shown in Figure 8-3.



**Figure 8-3. Typical Daisy-Chain Modbus/RS485 Network**

#### NOTE

The WHMS Manager does not necessarily have to be on either end of the Daisy-Chain loop.

Any one of the C-More WHM units included in the Modbus network can be the Manager. However, it is recommended that you decide which unit will be the Manager and which will be the last unit on the daisy-chain prior to performing the wiring connections. This will simplify wiring connections and Modbus address assignments.

Modbus network wiring connections must be made using shielded twisted-pair wiring, (18 – 24 AWG) such as Belden #9841, #3105A, #8760, or equivalent. The Modbus wiring connections are made at the RS485 COMM terminals on the I/O board included with each C-more Control System.

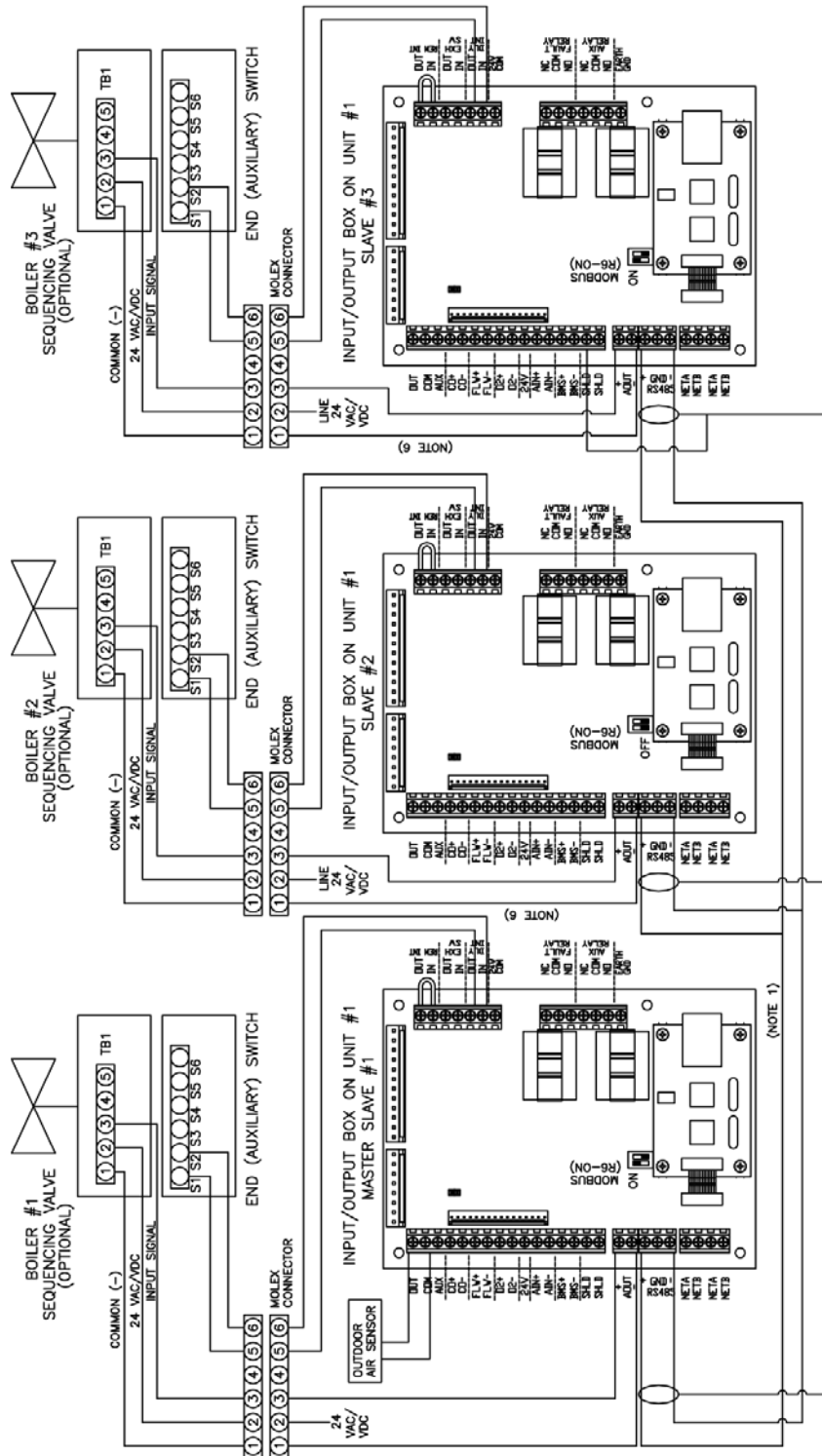
Connect the Modbus wiring as follows:

#### Modbus Network Wiring

1. Starting at the first unit, connect the twisted, shielded pair cable to the RS485 Comm plus (+) and minus (-) terminals on the left side I/O board as shown in Figure 8-4.
2. At the I/O board of the first unit in the daisy chain (not necessarily Manager), activate the **DIP** switch labeled “MODBUS TERM” by placing it in the up position. This will connect a termination resistor across the terminals at the source end.
3. Refer to Figure 8-4 and run the shielded cable to the next unit in the daisy-chain and connect the + and – wire leads (+ to +, - to -). **DO NOT** terminate the shield of the RS485 Comm leads to the SHIELD terminal at the Client. Instead, connect the shields of the incoming and outgoing RS485 leads together.
4. Continue connecting the + and - wire leads and shields for the remaining units as described in step 3 for the remaining Client units in the chain.
5. At the end unit in the chain, activate the **DIP** switch labeled “MODBUS TERM” by placing it in the up position. This will ensure that the termination resistors are activated at both ends of the loop.

**8.8.4 Control and Power Wiring**

Control and power wiring connections to the sequencing valves associated with each C-More WHM unit is accomplished by simply ensuring that the 4-pin Molex connectors on the units are connected to the corresponding connectors on the valves.



**NOTES:**

Wiring to be shielded twisted-pair cable (Belden 9841 or equivalent).

Complete the following instructions:

1. Activate DIP 1 (Modbus TERM) on the first *and* last units in the daisy chain.
2. Tie incoming/outgoing shields together and terminate at the shield terminal of the LAST WHMS Client in the chain.
3. On the CPU board inside the C-More Control Panel of the last unit on the

**Figure 8-4 WHMS Network Wiring Diagram**

### 8.9 WHM PROGRAMMING & START-UP

Prior to programming the required WHM Menu options into the WHM Manager and Clients, all required hardware installation and network wiring must be completed. In addition, the required menu entries to be entered must be determined based on the descriptions in the previous sections.

AERCO recommends that the WHM Manager be set up first. By doing so, the Manager will “push” most of the required menu entries to each WHM Client as each unit is brought on-line. The following steps assume that the WHM Manager and Clients will be consecutively numbered, starting at 1 (WHM Manager). Proceed as follows starting at the unit which has previously been determined to be the WHM Manager:

#### WHM Programming & Start-Up Procedure

1. Access the Setup menu and scroll to the **Comm** Address option. Press the **CHANGE** key.
2. Enter **1** for the Comm Address of the Manager. Press the **ENTER** key to store the entry.
3. Access the WHM menu and scroll to the **WHM Mode** option.
4. Press the **CHANGE** key.
5. Select **WHM Manager** and then press the **ENTER** key to store the entry. Note that the Outlet Temperature display on the WHM Manager will begin flashing every two seconds.
6. Select the **WHM Setpoint** option. If you want to change the current setpoint for WHM, press the **CHANGE** key.
7. Enter the desired **WHM Setpoint** temperature and then press **ENTER** to store the selection.
8. Scroll to the **WHM Nxt On** option. If you want to change the value, press the **CHANGE** key.
9. Enter the desired value for **WHM Nxt On** and then press **ENTER** to store the selection.
10. Scroll to the **WHM Nxt Off** option. If you want to change the value, press the **CHANGE** key.
11. Enter the desired value for **Nxt Off** and then press **ENTER** to store the selection.
12. Scroll to the **Lead/Lag Hours** option. If you want to change the value, press the **CHANGE** key.
13. Enter the desired value for the **Lead/Lag Hours** option and then press **ENTER** to store the selection.
14. The WHM menu contains **Setback** options, which are used to adjust the setpoint temperature, start time and end time during periods of low DHW demand. These options are selected in steps 15 through 18, below.
15. To specify the setback temperature, scroll to the **Setback Setpoint** option. If you want to change the value, press the **CHANGE** key.
16. Enter the desired **Setback Setpoint** temperature and then press **ENTER** to store the selection.
17. Next, the **Setback Start** and **Setback End** time options must be specified (defaults = 12:00am for both options). To change each option scroll to **Setback Start** or **Setback End** and press the **CHANGE** key.
18. Separately enter the desired Start and End time (12:00am to 11:59pm) and then press **ENTER** to store each entry.

### WHM Programming & Start-Up Procedure

19. This completes the required entries for the WHM Manager. All but two of the required menu setting will be automatically “pushed” to the WHM Clients as they are brought on-line. The options that are **not** “pushed” to each WHM Client are:
  - Comm Address (in Setup menu)
  - WHM Mode
20. Enter the desired Comm Address and WHM Mode (WHM Client) at the C-More Control Panel on each of the WHM Clients on the network.
21. After the required entries are made at each WHM Client, check to ensure the **REMOTE** LED on the C-More Control Panel for each unit in the WHM network is illuminated. When illuminated, it indicates that RS485 communications are operating properly.
22. The WHM menu contains two additional menu options which can be set at the WHM Manager. These options are **WHM Auto Mstr** and **WHM Auto Timer**. In order to view or change these two options, the Level 2 Password (6817) must be entered as follows:
  - a. Press the **MENU** key on the front panel of the C-More and access the Setup Menu.
  - b. Scroll to the **Password** menu option and press the **CHANGE** key.
  - c. Enter **6817** and then press the **ENTER** key to store the password.
  - d. Press the **MENU** key on the C-More and scroll back to the **WHM** Menu.
23. Scroll to the **WHM Auto Mstr** option. The default value for this option is Off (disabled). If you wish to enable this option, select Yes and then press the **ENTER** key to store the setting.
24. If the **WHM Auto Mstr** option was set to Yes (enabled) in step 23, proceed to step 25. If this option remains set to No (disabled), skip step 25 and go to step 26.
25. Scroll to the **WHM Auto Timer** option. This option is used to select the elapsed time interval between failure of the WHM Manager and switch-over to a new WHM Manager. If desired, this time interval can be changed to any value within the allowable range of 10 to 120 seconds. To alter this setting, press the **CHANGE** key and enter the desired time interval and then press **ENTER** to store the new setting.
26. The **WHM Auto Mstr** and **WHM Auto Timer** options will be automatically “pushed” to the WHM Clients on the network.

**This completes all programming for the WHM.**



## 8.10 TROUBLESHOOTING

Faults which may occur during WHM operation include the items listed in Table 8-3.

<b>Table 8-3. WHM Troubleshooting</b>		
<b>FAULT INDICATION</b>	<b>PROBABLE CAUSE</b>	<b>CORRECTIVE ACTION</b>
OUTLET TEMPERATURE display is flashing on 2 C- More Control Panels	1. Two C-Mores have their WHM Mode menu option set to WHM Manager	1. Check the WHM Mode entries in the units which have their displays flashing. Change one of the WHM Mode settings to WHM Client.
<b>REMOTE</b> LED on one or more WHM units is Off.	1. Improperly connected or faulty RS485 Modbus wiring.  2. Improper Comm address.  3. Unit Comm address is not unique.	1. Check the polarity of the RS485 Comm connections on the I/O board of the affected unit. Also, ensure that all Modbus wiring connections to the unit are secure.  2. Verify that the address of the affected unit is within the allowable range (1 thru 8).  3. Check to ensure that none of the units have the same Comm address.
Actuator-controlled sequencing valve does not open	1. Control cable not connected to valve actuator.  2. 24 VAC power not being supplied to valve actuator.  3. Defective valve actuator.	1. Ensure that the control cable from the unit's I/O Box is connected to the valve actuator.  2. Remove the enclosure cover from the valve actuator and verify that 24 VAC is present at Terminal 2 of the actuator.  3. Replace valve actuator. Following replacement, the actuator stroke will have to be calibrated to ensure it fully opening and closing.



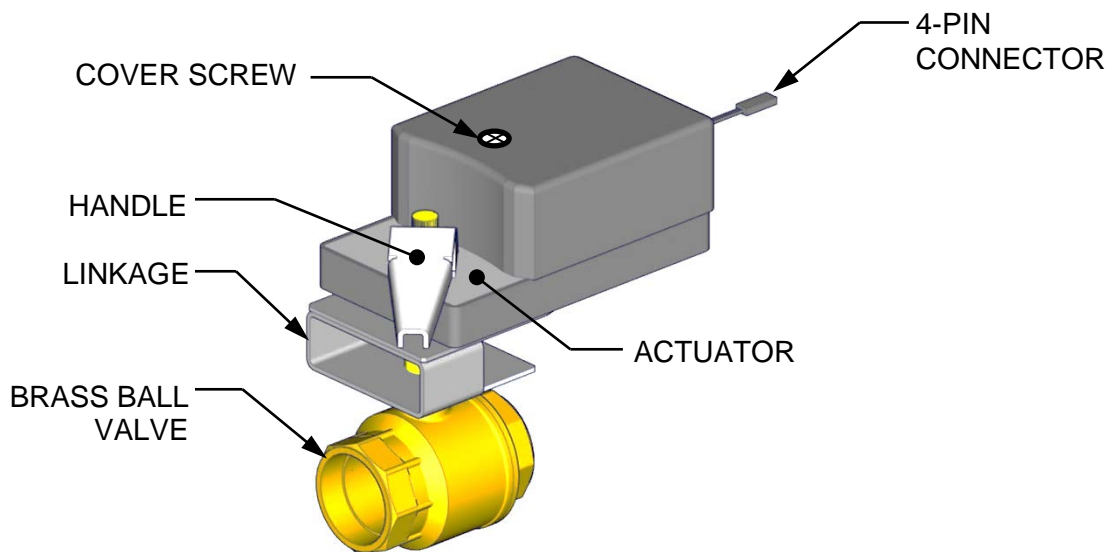
## 8.11 SEQUENCING VALVE DESCRIPTION & OPERATION

Brief descriptions of Actuator-Controlled Sequencing Valve (P/N 92123) and its operating characteristics are provided below in Sections 8.11.1 and 8.11.2, respectively. The installation of the valve itself is described in Chapter 2, Section 2.5.1.

### 8.11.1 Sequencing Valve Description

The Actuator-Controlled Sequencing Valve shown in Figure 8-5 is comprised of the following main components:

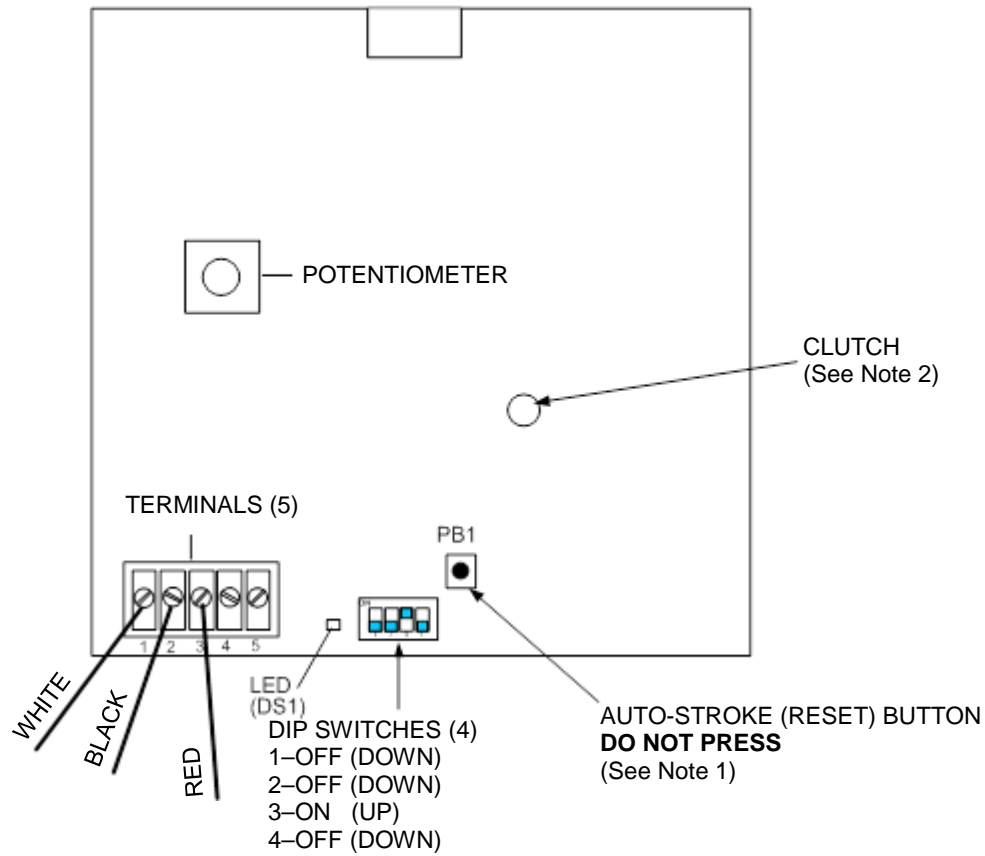
- 2" Brass Ball Valve
- Actuator Linkage
- Actuator Housing
- Valve Shaft Handle



**Figure 8-5. Actuator-Controlled Sequencing Valve (P/N 92123)**

The Actuator Housing contains a cover which is removed by simply loosening a single captive screw. Removing the cover provides access to a PC Board containing wiring connections and control circuitry components as shown in Figure 8-6.

The components on the PC board include **DIP** switches which are preset at the factory and should not be changed unless instructed to do so.



**NOTES:**

1. **DO NOT** press Auto-Stroke (Reset) button. Doing so may alter actuator calibration.
2. Depress and hold brass clutch button to manually rotate valve.

**Figure 8-6. Actuator PC Board Components**

**CAUTION!**

Power must be removed from the Actuator prior to attempting to disengage the clutch. Failure to observe this precaution may damage the Actuator.

The PC board also contains a brass button which is used to disengage the clutch and permit the ball valve to be manually rotated. To disengage the clutch, proceed as follows:

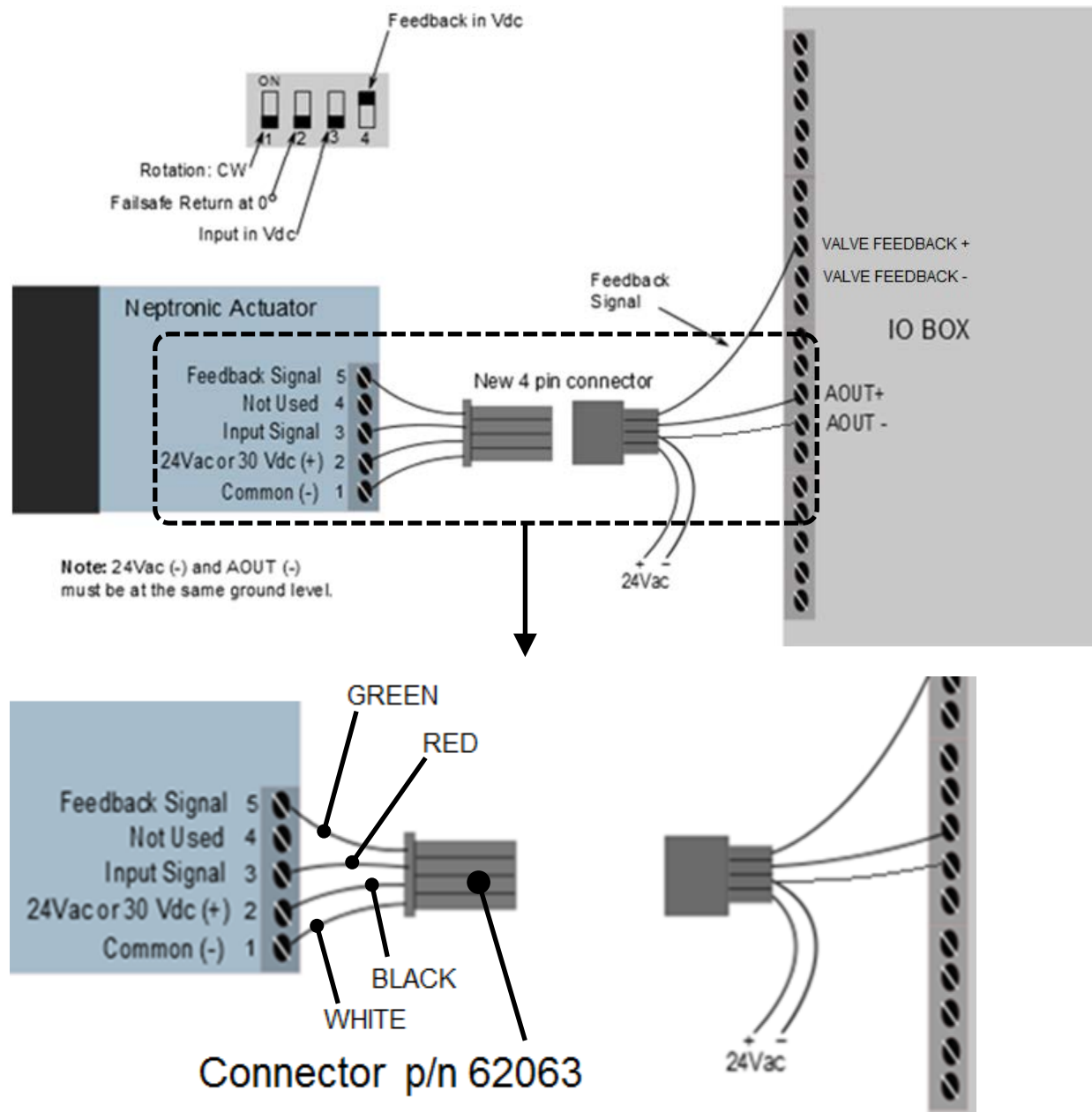
**Actuator Clutch Disengagement Instructions**

1. Disconnect the 4-pin connector on the Actuator to ensure that 24 VAC power is not being supplied
2. Press and hold the brass **CLUTCH** button shown in Figure 8-6.
3. With the **CLUTCH** button depressed, the ball valve can be manually rotated from the fully open (90°) to the fully closed (0°) position.

**8.11.2 Sequencing Valve Operating Characteristics**

The Sequencing Valve is powered by 24 VAC which is supplied from a step-down transformer located in the Power Box of the Innovation Water Heater. The 24 VAC power output and a 2 to 10 VDC control signal from the I/O Box of the Water Heater are routed to the Sequencing Valve via a 4-pin Molex connector.

During normal Water Heater Management (WHM), a control signal of less than (<) – 2 VDC will rotate the valve to the fully open (90°) position. Conversely, a control signal above 8 VDC will rotate the valve to the fully closed (0°) position. The sequencing valve will send a status of the Valve (open/close) as a feedback signal (2 – 10 VDC) to the C-More.



**Figure 8-7. Sequencing Valve Wiring**

(This Page Is Intentionally Blank)

**APPENDIX A – Innovation Menu Item Descriptions**

**Table A-1: Operating Menu Item Descriptions**

See Section 3-4 for a range of choices and the default values.

<b>Table A-1: OPERATING MENU ITEM DESCRIPTIONS</b>		
<b>MENU LEVEL &amp; OPTION</b>		<b>DESCRIPTION</b>
1	Active Setpoint	This is the setpoint temperature to which the control is set when operating in the Constant Setpoint or Remote Setpoint mode. When in the Constant Setpoint mode, this value is equal to the Internal Setpoint setting in the Configuration Menu. When in the Remote Setpoint mode, this value is the setpoint equivalent to the remote analog signal supplied to the unit
2	Outlet Temp	Displays Outlet water temperature
3	Inlet Temp	Displays Inlet Water Temperature
4	Air Temp	For monitoring purposes only
5	Outdoor Temp	Displayed only if outdoor sensor is installed and enabled.
6	Valve Positn In	Desired input valve position. This is normally the same as the valve position shown on the bargraph when the heater is operating.
7	Valve Positn Out	Displays actual real time Valve Position
8	FFWD Temp	Displays Feed Forward Water Temperature
9	Exhaust Temp	Displays Exhaust Gas Temperature
10	Flame Strength	Displays flame strength from 0% to 100%.
11	Oxygen Level	Displays the Oxygen Level of combustion exhaust gases
12	Ignition Time	Displays the elapsed time between confirmation of gas valve opening (POC) until a stable flame is detected
13	SSOV Time to OPN	Displays the elapsed time between 120 VAC being applied to the Gas Valve and confirmation of gas valve opening (POC)
14	Spark Current	Displays current value.
15	Run Cycles	Displays the total number of run cycles from 0 to 999,999.
16	Run Hours	Displays total run time of unit in hours from 0 to 9,999,999.
17	Fault Log	Displays information on the last 20 faults (0 – 19).
18	Manual Valve Pos	Selects Valve Position in Manual mode.

**Table A-2: Setup Menu Item Descriptions**

See Section 3-5 for a range of choices and the default values.

<b>Table A-2: SETUP MENU ITEM DESCRIPTIONS</b>		
<b>MENU LEVEL &amp; OPTION</b>		<b>DESCRIPTION</b>
<b>1</b>	Password	Allows password to be entered. Once the valid password (159) is entered, options in the Setup, Configuration and Tuning Menus can be modified.
<b>2</b>	Language	English only
<b>3</b>	Time	Displays time from 12:00 am to 11:59 pm.
<b>4</b>	Date	Displays dates from 01/01/00 to 12/31/99
<b>5</b>	Unit of Temp	Permits selection of temperature displays in degrees Fahrenheit (°F) or degrees Celsius (°C).
<b>6</b>	Comm Address	For RS-485 communications (0 to 127). Default address is 0. RS232 should have its own (programmable) password.
<b>7</b>	Baud Rate	Allows communications Baud Rate to be set (2400 to 19.2K).
<b>8</b>	OnAER Mode	Allows the selection of OnAER data destination medium between Ethernet and SD Card
<b>9</b>	Min Upload Timer	Sets the time between OnAER Heartbeat data transmissions
<b>10</b>	Unit Alpha	Sets the Alpha portion of a unit serial number
<b>11</b>	Unit Year	Sets the Year portion of a unit serial number
<b>12</b>	Unit Serial #	Sets the Number portion of a unit serial number
<b>13</b>	Software Version	Identifies the current software version of the C-More Controller (Ver 0.0 to Ver 9.9).

**Table A-3: Configuration Menu Item Descriptions**

See Section 3-6 for a range of choices and the default values.

<b>Table A-3: CONFIGURATION MENU ITEM DESCRIPTIONS</b>		
<b>MENU LEVEL &amp; OPTION</b>		<b>DESCRIPTION</b>
<b>1</b>	Internal Setpoint	Allows internal setpoint to be set.
<b>2</b>	Unit Type	INNOVATION Water Heater
<b>3</b>	Unit Size	600 MBH (175.8 kW), 800 MBH (234.5 kW), 1060 MBH (310.7 kW) or 1400 MBH (410.3 kW)
<b>4</b>	Fuel Type	Allows selection of Natural Gas or Propane.
<b>5</b>	Heater Mode	It allows selection of: Constant Setpoint, or Remote Setpoint.
<b>6</b>	Remote Signal	Used to set the type of external signal which will be used when operating in the Remote Setpoint mode.
<b>7</b>	Outdoor Sensor	Allows outdoor sensor function to be enabled or disabled.
<b>8</b>	System Start Tmp	In Outdoor Reset mode, the temperature above which the unit shuts down.
<b>9</b>	Setpoint Lo Limit	Used to set the minimum allowable setpoint 40°F (4.4°C) to Setpoint Hi Limit).
<b>10</b>	Setpoint Hi Limit	Used to set the maximum allowable setpoint (Setpoint Lo Limit to 190°F (87.8°C).
<b>11</b>	Temp Hi Limit	This is the maximum allowable outlet temperature (40 to 200°F (93.3°C). Any temperature above this setting will turn off the unit. The temperature must then drop 5°F (2.75°C) below this setting to allow the unit to run.
<b>12</b>	Max Valve Position	Sets the maximum allowable valve position for the unit (40% to 100%).
<b>13</b>	Pump Delay Timer	Specifies the amount of time (0 to 30 min.) to keep the pump running after the unit turns off.
<b>14</b>	Aux Start On Dly	Specifies the amount of time to wait (0 to 120 sec.) between activating the Aux Relay (due to a demand) and checking the pre-purge string to start the heater.
<b>15</b>	Failsafe Mode	Allows the Failsafe mode to be set to either Constant Setpoint or Shutdown.
<b>16</b>	Analog Output	Must be set to Valve Pos 0-10 V.
<b>17</b>	Lo Fire Timer	Specifies how long (2 to 600 sec.) to remain in the low fire position after ignition, before going to the desired output
<b>18</b>	Setpt Limiting	N/A for Water Heaters
<b>19</b>	Setpt Limit Band	N/A for Water Heaters



Table A-3: CONFIGURATION MENU ITEM DESCRIPTIONS		
MENU LEVEL & OPTION		DESCRIPTION
20	Network Timeout	Specifies the timeout value (seconds) before a Modbus fault is declared. Available settings range from 5 to 999 seconds.
21	Shutoff Delay Temp	This entry will reduce excessive ON/OFF cycling in AUTO mode. When the PID temperature Control tries to lower the valve position below the Stop Level, the unit will stay at the Stop Level (will not cycle OFF) until the Outlet Temperature rises above Setpoint Plus the Shutoff Delay Temp entry. <b>NOTE:</b> This feature is only active in <b>Constant Setpoint</b> and <b>Remote Setpoint</b> modes.
22	Demand Offset	This entry will reduce excessive ON/OFF cycling in AUTO mode. When this entry is a non-zero value, the unit will not turn on again until <i>Valve Position In</i> reaches the Start Level value AND the Outlet Temperature goes below the <i>Active Setpoint – Demand Offset</i> . In addition, the heater will fire at the 29% Valve Position level or below for a period of one minute.  When this entry is set to zero, the unit will turn on again as soon as the <i>Valve Position in</i> reaches the <i>Start Level</i> value. There will not be a one minute delay when firing at the 29% Valve Position level.
23	Deadband High	Deadband High and Deadband Low settings create an “Outlet Temperature” Zone. In which no Valve Position corrections will be attempted.  The Deadband ZONE is defined as operating with an Outlet Temperature between Active Setpoint + Deadband High and Active Setpoint – Deadband Low.  When the Outlet Temperature reaches Active Setpoint and remains there for a period of 15 seconds, the unit will go into a DEADBAND MODE at which point no Valve Position corrections will be attempted while the Outlet Temperature remains anywhere within the Deadband ZONE. When the unit is in the DEADBAND MODE, the °F or °C LED will flash on and off. When the Outlet Temperature drifts out of the Deadband ZONE, the DEADBAND MODE will be terminated and the PID LOOP will again attempt Valve Position corrections.
24	Deadband Low	
25	IGST Version	Displays the IGST Board Version Installed in the C-More
26	IGN Time Setting	Displays the active Ignition Time setting (4 seconds or 7 seconds) as defined by the P4 Harness
27	Diag Valve Pos 1	First diagnostic valve position
28	Diag Valve Pos 2	Second diagnostic valve position
29	Diag Valve Pos 3	Third diagnostic valve position

<b>Table A-3: CONFIGURATION MENU ITEM DESCRIPTIONS</b>		
<b>MENU LEVEL &amp; OPTION</b>		<b>DESCRIPTION</b>
<b>30</b>	Diag Valve Pos 4	Fourth diagnostic valve position
<b>31</b>	Diag Valve Pos 5	Fifth diagnostic valve position
<b>32</b>	Ignited Time	Time firing at each valve position
<b>33</b>	Diag Loop Repeat	Number of complete loops to repeat
<b>34</b>	Self Diag RUN	Enable or disable diagnostic run
<b>35</b>	VP Loop Time	Monitor VP, loop count, time of current VP
<b>36</b>	Highest Ign Time	Highest time to ignite in diagnostic

**Table A-4: Tuning Menu Item Descriptions**

See Section 3-7 for a range of choices and the default values.

<b>Table A-4: TUNING MENU ITEM DESCRIPTIONS</b>			
<b>MENU LEVEL &amp; OPTION</b>		<b>DESCRIPTION</b>	
<b>1</b>	Prop Band	Generates a valve position based on the error that exists between the setpoint temperature and the actual outlet temperature. If the actual error is less than the proportional band setting (1°F to 120°F, 0.55°C to 66°C), the fire rate will be less than 100%. If the error is equal to or greater than the proportional band setting, the valve position will be 8%.	
<b>2</b>	Integral Gain	This sets the fraction of the output, due to setpoint error, to add or subtract from the output each minute to move towards the setpoint. Gain is adjustable from 0.00 to 10.00	
<b>3</b>	Derivative Time	This value (0.0 to 20.0 min.) responds to the rate of change of the setpoint error. This is the time that this action advances the output.	
<b>4</b>	Min Load Adj	Setting is adjustable from -50°F to +50°F. It adjusts the output by adding an offset to the breakpoint chart at minimum flow. This is used to fine tune Feed-Forward (FFWD) output at low flow levels.	
<b>5</b>	Max Load Adj	Setting is adjustable from -50°F to +50°F (-45.5 to +10 °C). It adjusts the output by changing the scaling of the breakpoint chart at maximum flow.	
<b>6</b>	FFWD Temp	Displays the Feed-Forward temperature.	
<b>7</b>	Outlet Feedback	Used to Enable or Disable feedback. Disable this function for Feed-Forward control only.	
<b>8</b>	Feedback Gain	Adjustable from 0.01 to 1.00 (See NOTE below)	
<b>9 Thru 19</b>	Breakpoint at 100% Thru Breakpoint at 0%	Allows breakpoint temperature settings 30°F to 240°F (4.4°C to 115.6°C), to be entered for 100% to 0% in 10% increments.	
Warmup		The feature embodied in the next three menu items eliminates Temperature Overshoots during the “Warmup” period of a cold ignition cycle on all boilers by temporarily modifying the PID Gain parameter during warmup and for a period defined in the Tuning Menu.	
<b>20</b>	Warmup Prop Band	Range = 1 – 120°F (0.55°C to 66°C)	Default = 95 (52°C)
<b>21</b>	Warmup Int Gain	Range = 0.00 – 2.00	Default = 0.50
<b>22</b>	Warmup PID Timer	Range = 0 - 240 seconds	Default = 20 seconds

# Innovation Installation, Operation & Maintenance – KOREA EDITION

## APPENDIX A – INNOVATION MENU ITEM DESCRIPTIONS

<b>Table A-4: TUNING MENU ITEM DESCRIPTIONS</b>		
<b>MENU LEVEL &amp; OPTION</b>		<b>DESCRIPTION</b>
<b>WHM Items</b> – the following item appear only if WHM is enabled		
<b>23</b>	FDbk Start Pos	Start of Feedback Position
<b>24</b>	Fdbk End Pos	End of Feedback Position
<b>25</b>	Max Feedback	Max Feedback
<b>26</b>	Fdbk Value	Monitor Feedback Value
<b>27</b>	Temp Gov Enable	Enables or Disables the Temperature Governor function. The Temperature Governor aggressively reduces the effective Fire Rate as the Outlet Temperature approaches the High Temperature Limit.
<b>28</b>	GOV Limit-5	When the Outlet Temperature exceeds the HIGH TEMPERATURE LIMIT -5, the effective Fire Rate will be reduced by the value entered in “GOV Limit -5”
<b>29</b>	GOV Limit-7	When the Outlet Temperature exceeds the HIGH TEMPERATURE LIMIT -7, the effective Fire Rate will be reduced by the value entered in “GOV Limit -7”
<b>30</b>	GOV Limit-10	When the Outlet Temperature exceeds the HIGH TEMPERATURE LIMIT -10, the effective Fire Rate will be reduced by the value entered in “GOV Limit -10”
<b>31</b>	GOV Limit-12	When the Outlet Temperature exceeds the HIGH TEMPERATURE LIMIT -12, the effective Fire Rate will be reduced by the value entered in “GOV Limit -12”
<b>32</b>	GOV Limit-15	When the Outlet Temperature exceeds the HIGH TEMPERATURE LIMIT -15, the effective Fire Rate will be reduced by the value entered in “GOV Limit -15”
<b>33</b>	PID Output	Calculated PID Output
<b>34</b>	P Output	Proportional Band Output
<b>35</b>	I Output	Integral Output
<b>36</b>	D Output	Derivative Output
<b>37</b>	Above 70 Fuel	For Factory Personnel ONLY
<b>38</b>	Below 70 Fuel	For Factory Personnel ONLY
<b>39</b>	Reset Defaults?	Allows Tuning Menu options to be reset to their Factory Default values.

**NOTE:**

Feedback Gain (Item 8) is only displayed when Heater Tuning Display is enabled by factory authorized personnel.

**Table A-5: Calibration Menu Item Descriptions**

See Section 3-8 for a range of choices and the default values.

<b>Table A-5: CALIBRATION MENU ITEM DESCRIPTIONS</b>		
<b>MENU LEVEL &amp; OPTION</b>		<b>DESCRIPTION</b>
1	Stepper Fbk	Allows the Air/Fuel Valve stepper motor feedback current to be calibrated at the 0% (fully closed) and 100% (fully open) positions. Verification can also be accomplished at the 50% position.
2	Purge Timer	Allows adjustment of the pre-ignition purge time.
3	Post Purge Timer	Allows adjustment of the purge time when a unit shuts down.
4	IGN Position	Allows adjustment of the valve position (Fire Rate) during the ignition sequence.
5	FFWD Temp Dsply	Enabled or Disabled.
6	Outlet Tmp Dsply	Enabled or Disabled.
7	Inlet Tmp Dsply	Enabled or Disabled.
8	Valv Pos Out Dsp	Enabled or Disabled.
9	Exhaust Tmp Dsp	Enabled or Disabled.
10	Exhaust Safety	Enabled or Disabled.
11	Flue Material	Select flue material: PVC, Polypropylene, or stainless
12	Exhst Fault Temp	Fault threshold temperature
13	Exhst Module Temp	Decreases Valve Position to lower exhaust temperature.
14	Exhst Warn Temp	Flue temperature high warning
15	Exhst Tmp VP Adj	VP adjust value
16	Exhst Adj Rate	VP adjust rate
17	VP Up Rate	Allows adjustment of the Valve Position (Fire Rate) increase rate when raising the Valve Position. VP Up Rate is defined as Seconds per Step.
18	VP Down Rate	Allows adjustment of the Valve Position (Fire Rate) decrease rate when lowering the Valve Position. VP Down Rate is defined as Seconds per Step.
19	Purge Blwr Offst	Allows adjustment of the blower speed (Blower Output Voltage) during the Purge cycle.
20	4-20mA Purge Pct	Allows adjustment of the blower speed (Blower Output Voltage) during the Purge cycle when using an Emerson VFD Drive to control the Blower Motor.
21	PWM In Adj	Allows the Pulse Width Modulation (PWM) duty cycle to be adjusted from -5.0% to +5.0% in 0.1% increments.
22	Analog In Adj	Allows adjustment of the analog input from -5.0% to +5.0%.
23	Flow In Adj	Allows adjustment of the water Flow Rate Input from -5.0% to +5.0%.

<b>Table A-5: CALIBRATION MENU ITEM DESCRIPTIONS</b>		
<b>MENU LEVEL &amp; OPTION</b>		<b>DESCRIPTION</b>
<b>24</b>	Supply Gas Pressure In Adj	Allows adjustment of the Supply Gas Pressure level from -5.0% to +5.0% in 0.1 % increments.
<b>25</b>	Gas Plate dp In Adj	Allows adjustment of the Gas Plate dp level from -5.0% to +5.0% in 0.1% increments.
<b>26</b>	mA Out Adj	Allows adjustment of the milliamp output from -5.0 mA to +5.0 mA.
<b>27</b>	A/F Sensitivity	Allows adjustment of the Air/Fuel (A/F) Valve stepper motor sensitivity to be adjusted from 1% to 5% in 1% increments.
<b>28</b>	Power Reset	Allows the Power Reset Option to be set to AUTO or MANUAL.
<b>29</b>	Water Temp Reset	Allows the Water Temperature Reset function to be set to AUTO or MANUAL.
<b>30</b>	Gas Press Reset	Allows the Gas Pressure Reset function to be set to AUTO or MANUAL.
<b>31</b>	Min Off Time	Allows the minimum Off time to be set from 0 to 10 minutes.
<b>32</b>	Heatr Tuning Dsp	Allows Heater Tuning Display to be Enabled or Disabled.
<b>33</b>	Heatr Bkpt Dsp	Allows Heater Breakpoint Display to be Enabled or Disabled. When Enabled, Breakpoints can be viewed and/or changed.
<b>34</b>	Stop Level	Allows the Stop Level to be set to a valve position ranging from 0% to the presently set Start Level.
<b>35</b>	Start Level	Allows the Start Level to be set to a valve position ranging from the presently set Stop Level to a maximum of 40%.
<b>SKIP FEATURE:</b>		
Items 36 – 38 embody a feature that allows the user to define a Fire Zone the C-More will avoid. In the rare instance when a unit emits an objectionable noise at a certain Fire Rate and no other remedy solves the problem, a Fire Rate skip zone may be defined to command the C-More to Skip-Over the defined Fire Rate.		
<b>36</b>	– Skip Range Cntr	Defines the Center (Fire Rate) of the skip band.
<b>37</b>	– Skip Range Span	Defines the + and – band of the Skip Zone Size.
<b>38</b>	– Skip Speed	Defines the speed (Seconds/Fire Rate) at which the band will be skipped.
<b>O2 Settings:</b>		
Items 39 – 342 allow calibration of oxygen readings.		
<b>39</b>	– O2 Gain	Range = 0.5 to 1.5. (Unity Gain, No Mods)
<b>40</b>	– O2 Offset	Range = -3.0 to +3.0.
<b>41</b>	– O2 Sensor	Enables the O2 Sensor
<b>42</b>	Cal Temp Sensors	Allows calibration of the temperature sensor

<b>Table A-5: CALIBRATION MENU ITEM DESCRIPTIONS</b>		
<b>MENU LEVEL &amp; OPTION</b>		<b>DESCRIPTION</b>
<b>Temperature Channel Offset:</b>		
Items 36 – 41 embody the feature, which allow the user to field calibrate all six temperature channels by entering an offset corresponding to the desired temperature channel.		
<b>43</b>	– FFWD Temp Offset	Range: -20 to + 20 (either °F or °C)
<b>44</b>	– Exhst Tmp Ofset	Range: -20 to + 20 (either °F or °C)
<b>45</b>	– Outdr Air Offset	Range: -20 to + 20 (either °F or °C)
<b>46</b>	– Inlet Air Offset	Range: -20 to + 20 (either °F or °C)
<b>47</b>	– Inlet Wtr Offset	Range: -20 to + 20 (either °F or °C)
<b>48</b>	– Outlet Wtr Offset	Range: -20 to + 20 (either °F or °C)
<b>49</b>	24 hr Max Cycles	Maximum cycles in 24 hour period.
<b>50</b>	24 hr Max Ovrtpm	Maximum over-temp in 24 hour period.
<b>51</b>	0-10v Out Test	Set the blower voltage at 0-10v for testing.
<b>52</b>	Spark Monitor	Enables or disables the Spark Monitor function, which displays the AC current on the input of the Ignition Transformer.
<b>53</b>	Min Spark Amps	Allows the adjustment of the minimum spark current required at the spark transformer input.
<b>54</b>	Max Spark Amps	Allows the adjustment of the maximum spark current required at the spark transformer input.



**APPENDIX B – Startup, Status And Fault Messages**

<b>Table B-1. STARTUP and STATUS Messages</b>	
<b>MESSAGE</b>	<b>DESCRIPTION</b>
DEMAND DELAY XX sec	Displayed if Demand Delay is active.
DISABLED HH:MM pm, pm MM/DD/YY	Displayed if ON/OFF switch is set to <b>OFF</b> . The display also shows the time (am or pm) and date that the unit was disabled.
FLAME PROVEN	Displayed after flame has been detected for a period of 2 seconds. Initially, the flame strength is shown in %. After 5 seconds has elapsed, the time and date are shown in place of flame strength.
IGNITION TRIAL XX sec	Displayed during ignition trial of startup sequence. The duration of cycle counts up in seconds.
PURGING XX sec	Displayed during the purge cycle during startup. The duration of the purge cycle counts up in seconds.
STANDBY	Displayed when ON/OFF switch is in the <b>ON</b> position, but there is no demand for heat. The time and date are also displayed.
WAIT	Prompts the operator to wait.
WARMUP XX sec	Displayed for 2 minutes during the initial warm-up only.

<b>Table B-2. FAULT Messages</b>	
<b>FAULT MESSAGE</b>	<b>FAULT DESCRIPTION</b>
AIRFLOW FAULT DURING PURGE	The <b>Blower Proof</b> switch opened during purge, or air inlet is blocked.
AIRFLOW FAULT DURING IGN	The <b>Blower Proof</b> switch opened during ignition.
AIRFLOW FAULT DURING RUN	The <b>Blower Proof</b> switch opened during run.
DELAYED INTERLOCK OPEN	The Delayed Interlock is open.
DIRECT DRIVE SIGNAL FAULT	The direct drive signal is not present or is out of range.
FFWD TEMP SENSOR FAULT	The temperature measured by the Feed Forward (FFWD) Sensor is out of range.
FLAME LOSS DURING IGN	The Flame signal was not seen during ignition or lost within 5 seconds after ignition.
FLAME LOSS DURING RUN	The Flame signal was lost during run.
HEAT DEMAND FAILURE	The Heat Demand Relays on the Ignition board failed to activate when commanded.
HIGH EXHAUST TEMPERATURE	The <b>High Exhaust Temperature Limit</b> switch is closed.
GAS PRESSURE FAULT	The <b>High Gas Pressure Limit</b> switch OR Low Gas Pressure Limit switch is open.
HIGH WATER TEMPERATURE	The temperature measured by the Outlet Sensor exceeded the Temp Hi Limit setting.
HIGH WATER TEMP SWITCH OPEN	The <b>High Water Temperature Limit</b> switch is open.
IGN BOARD COMM FAULT	A communication fault has occurred between the PMC board and Ignition board.
IGN SWITCH CLOSED DURING PURGE	The <b>Ignition Position Limit</b> switch on the Air/Fuel Valve closed during purge.
IGN SWITCH OPEN DURING IGNITION	The <b>Ignition Position Limit</b> switch on the Air/Fuel Valve opened during ignition.
INTERLOCK OPEN	The Remote Interlock is open.
LINE VOLTAGE OUT OF PHASE	The Line (Hot) and Neutral wires are reversed.
LOW WATER LEVEL	The Low Water Cutoff board is indicating low water level.
NETWORK COMM FAULT	The RS-485 network information is not present or is corrupted.
OUTDOOR TEMP SENSOR FAULT	The temperature measured by the Outdoor Air Sensor is out of range.

# Innovation Installation, Operation & Maintenance – KOREA EDITION

## APPENDIX B – Startup, Status And Fault Messages

<b>Table B-2. FAULT Messages</b>	
OUTLET TEMP SENSOR FAULT	The temperature measured by the Outlet Sensor is out of range: OUTLET TEMPERATURE display = SHt Indicates sensor is shorted OUTLET TEMPERATURE display = OPn indicates sensor is open-circuited
PRG SWITCH CLOSED DURING IGNITION	The <b>Purge Position Limit</b> switch on the Air/Fuel Valve closed during ignition.
PRG SWITCH OPEN DURING PURGE	The <b>Purge Position Limit</b> switch on the Air/Fuel Valve opened during purge.
RECIRC PUMP FAILURE	Internal Recirculation Pump has failed.
REMOTE SETPT SIGNAL FAULT	The Remote Setpoint signal is not present or is out of range.
RESIDUAL FLAME	The Flame signal was seen for more than 60 seconds during standby.
SSOV SWITCH OPEN	The SSOV switch opened during standby.
SSOV FAULT DURING PURGE	The SSOV switch opened during purge.
SSOV FAULT DURING IGN	The SSOV switch closed or failed to open during ignition.
SSOV FAULT DURING RUN	The SSOV switch closed for more than 15 seconds during Run.
SSOV RELAY FAILURE	A failure has been detected in one of the relays that control the SSOV.
STEPPER MOTOR FAILURE	The Stepper Motor failed to move the Air/Fuel Valve to the desired position.
WARNING EXHAUST TEMP HIGH (Flashing)	The exhaust gas sensor is measuring high temperature. Level #1: 180°F (82.2°C), Flash WARNING Level #2: 190°F (87.8°C), Govern fire rate/flash WARNING Level #3: 200°F (93.3°C), Shut down unit (requires manual reset)

(This Page Is Intentionally Blank)

## APPENDIX C – Temperature Sensor Resistance/Voltage Chart

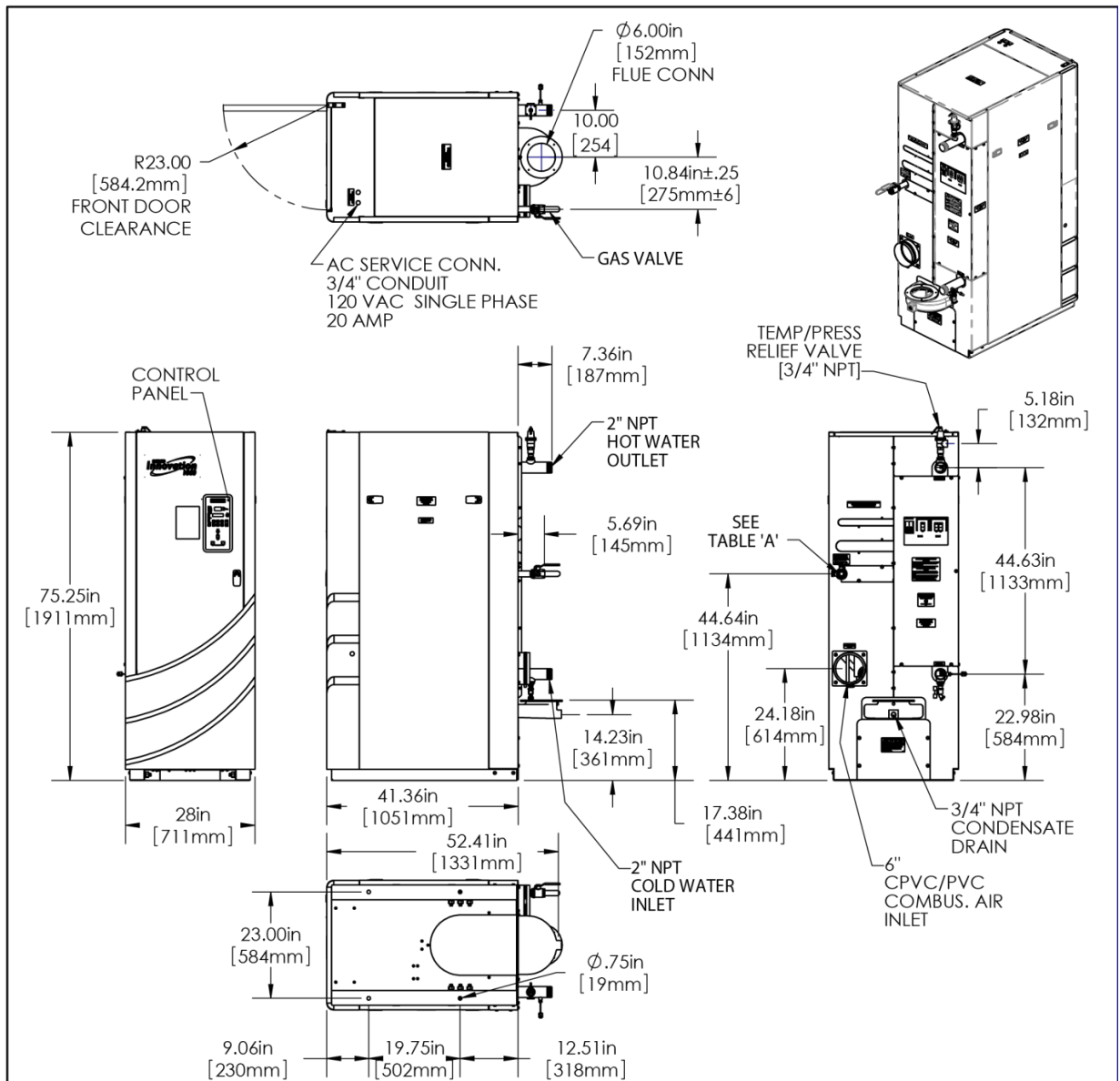
### TEMPERATURE SENSOR RESISTANCE/VOLTAGE CHART (BALCO)

TEMPERATURE		RES (OHMS)	VOLTS*
°F	°C		
-40	-40	779.0	1.93
-30	-34.4	797.5	1.96
-20	-28.9	816.3	1.99
-10	-23.3	835.4	2.02
0	-17.2	854.8	2.05
10	-12.2	874.6	2.07
20	-6.7	894.7	2.10
30	-1.1	915.1	2.12
40	4.4	935.9	2.15
50	10	956.9	2.17
60	15.5	978.3	2.20
70	21.1	1000.0	2.23
80	26.7	1022.0	2.25
90	32.2	1044.4	2.27
100	37.8	1067.0	2.30
110	43.3	1090.0	2.32
120	48.9	1113.3	2.34
130	54.4	1137.0	2.36
140	60	1160.9	2.39
150	65.6	1185.2	2.41
160	71.1	1209.5	2.43
170	76.7	1234.7	2.45
180	82.2	1260.0	2.47
190	87.8	1285.6	2.50
200	93.3	1311.4	2.52
210	98.9	1337.7	2.54
220	104.4	1364.2	2.56
230	110	1391.0	2.58
240	115.6	1418.2	
250	121.1	1445.7	

\*Voltage at AUX & Common terminals in the I/O Box

(This Page Is Intentionally Blank)

APPENDIX D – Dimensional Drawings



HEAT EXCHANGER DESIGN STANDARDS			
	MAX. WORKING PRESS.	MAXIMUM	TEST PRESS.
SHELL SIDE	160 PSIG (1103 kPa)	210 °F 98.9°C	240 PSIG (1655 kPa)
ASME B & PV CODE SECTION IV STAMP HLW			

MATERIALS OF CONSTRUCTION	
PRESSURE VESSEL	SHELL: [USA] 3/16" THK, STAINLESS 439, SA-240 [CANADA] 3/16" THK STAINLESS 304L, SA-312 [ELECTROLESS NICKEL PLATED]
COMBUSTION CHAMBER	316L STAINLESS HELICAL TUBES, SA-249 DOMED HEAD: 316 STAINLESS, SA-240 TUBESHEET: STAINLESS 316, SA-240 1/4" WALL WELDED TUBE SA-312 TP316 [ALL ELECTROLESS NICKEL PLATED]

TABLE 'A'		
MODEL	NAT GAS INLET CONNECTION	PROPANE INLET CONNECTION
INN600	1" NPT	1/2" NPT
INN800		1/2" NPT
INN1060		3/4" NPT
INN1400		3/4" NPT

ALL DIMENSIONS ARE IN INCHES [mm]

**AERCO** INTERNATIONAL INC.  
Blauvelt, NY 10913

**AERCO INNOVATION**  
600/800/1060/1400  
DIMENSIONAL OUTLINE

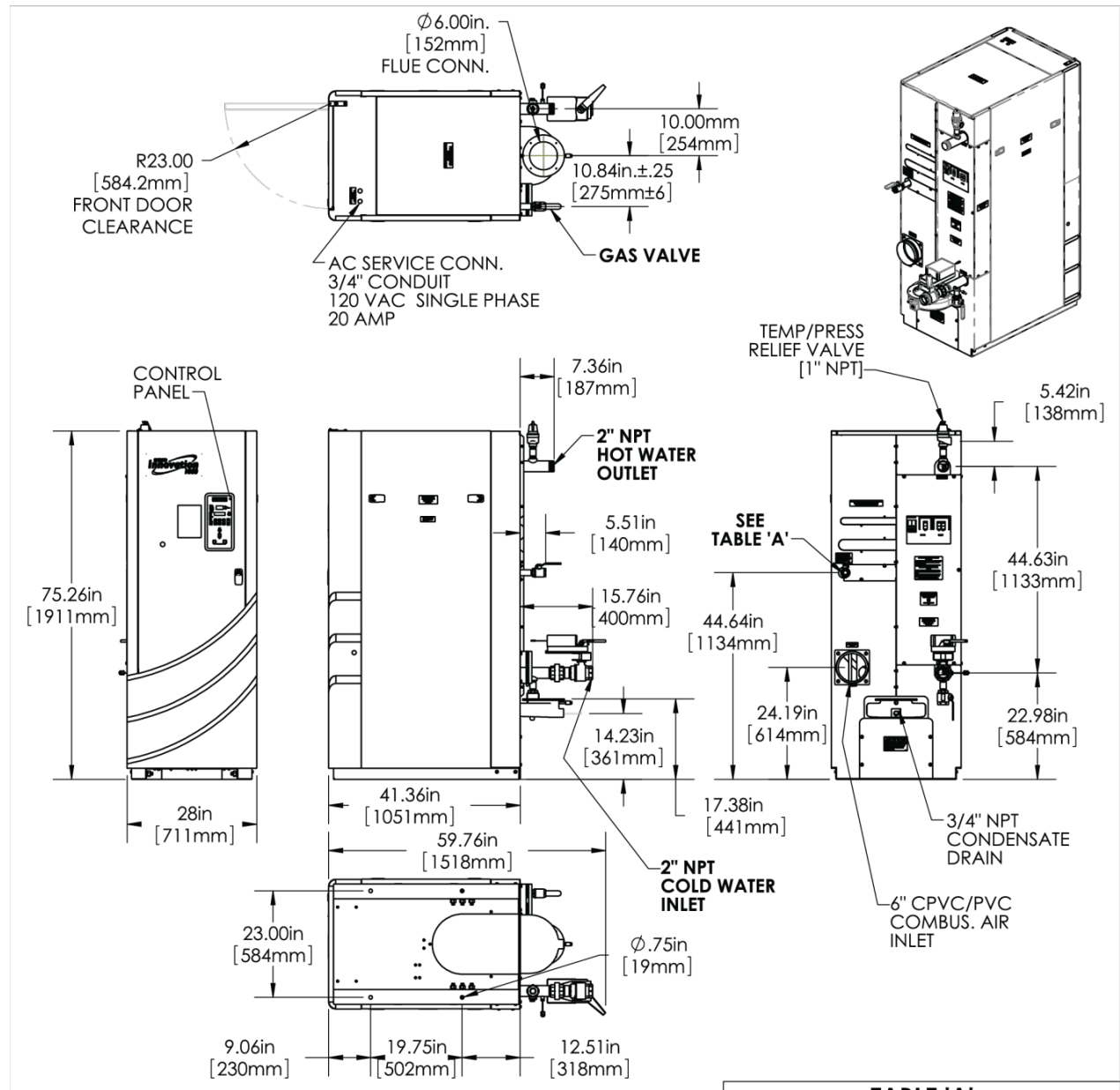
DWN. BY: _____	DATE: 4-10	DWG. NO.: _____	REV _____
SCALE: _____	SIZE: _____	AP-A-888	K
APPD BY: _____	REV DATE: _____		

Drawing Number: AP-A-888 rev K



# Innovation Installation, Operation & Maintenance – KOREA EDITION

## APPENDIX D – DIMENSIONAL DRAWINGS



HEAT EXCHANGER DESIGN STANDARDS			
	MAX. WORKING PRESS. (PSIG)	MAXIMUM TEMP. (°F)	TEST PRESS. (PSIG)
SHELL SIDE	160 PSIG (1103 kPa)	210°F (98.9 °C)	240 PSIG (1655 kPa)
ASME B & PV CODE SECTION IV STAMP HLW			

TABLE 'A'		
MODEL	NAT GAS INLET CONNECTION	PROPANE INLET CONNECTION
INN600SV	1" NPT	1/2" NPT
INN800SV		1/2" NPT
INN1060SV		3/4" NPT
INN1400SV		3/4" NPT

MATERIALS OF CONSTRUCTION	
PRESSURE VESSEL	SHELL: [USA] 3/16" THK, STAINLESS 469, SA-240 [CANADA] 3/16" THK, STAINLESS 304L, SA-312 [ELECTROLESS NICKEL PLATED]
COMBUSTION CHAMBER	316L STAINLESS HELICAL TUBES, SA-249 DOMED HEAD: 316 STAINLESS, SA-240 TUBESHEET: STAINLESS 316, SA-240 1/4" WALL WELDED TUBE SA-312 TP316 [ALL ELECTROLESS NICKEL PLATED]

ALL DIMENSIONS ARE IN INCHES [mm]

**AERCO INTERNATIONAL INC.**  
Blauvelt, NY 10913

AERCO Innovation 600/800/1060/1400  
w/SEQUENCING VALVE  
DIMENSIONAL OUTLINE

DWN. BY: HM	DATE: 4-11-12	DWG. NO.:	REV
SCALE: NTS	SIZE: A	<b>AP-A-902</b>	<b>D</b>
APPD BY:	REV DATE: 1-15-14		

Drawing Number: AP-A-902 rev D

# Innovation Installation, Operation & Maintenance – KOREA EDITION

## APPENDIX E – PARTS LIST DRAWINGS

### APPENDIX E – Parts List Drawings

#### Innovation 600/800/1060/1400 Parts List

Item #	Qty	Part #	Description
<b>Heat Exchanger</b>			
1	1	24336-8	PLATED HEAT EXCHANGER KIT INN600, INN800 <b>Assembly Kit</b>
	1	24336-9	PLATED HEAT EXCHANGER KIT INN 1060 <b>Assembly Kit</b>
	1	24336-7	PLATED HEAT EXCHANGER KIT INN 1400 <b>Assembly Kit</b>
<b>Exhaust Manifold &amp; Piping</b>			
2	1	44085-1	6" EXHAUST MANIFOLD
3	1	22246	DYNAMIC LOAD ANTICIPATOR ASSY INN 600/800/1060
		22225	DYNAMIC LOAD ANTICIPATOR ASSY INN 1400
4	1	92065-6	P&T VALVE, 3/4F X 3/4F
5	3	123449	TEMPERATURE SENSOR
6	1	92060	VALVE, 3/4" DRAIN
<b>Gas Train</b>			
7	1	22122	GAS TRAIN, INN600/800/1060, NAT GAS
	1	22179	½" GAS TRAIN, INN 600P/800P, PROPANE
	1	22180	¾" GAS TRAIN, 1060P, PROPANE
	1	22182-1	GAS TRAIN INN 1400, NATURAL GAS
	1	22182-4	¾" GAS TRAIN INN 1400P, PROPANE
8	1	24629-4	VALVE PROVING ASSEMBLY
<b>Burner, Air Fuel Delivery System</b>			
10	1	58039	BLOWER: AMETEK 8.9" <b>Replacement Kit</b>
11	1	24311-3	A/F VALVE ASSY, INN 600/800/1060 <b>Replacement kit</b>
	1	24311-4	A/F VALVE ASSY, INN 1400 ONLY <b>Replacement Kit</b>
12	1	59138	AIR FILTER: 6"
13	1	61024	AIR INLET TEMPERATURE SENSOR
14	1	44106	INTAKE MANIFOLD
15	1	44107	BLOWER SIDE INTAKE MANIFOLD
16	1	24335-1	LOW NOx BURNER ASSY <b>Replacement Kit</b>
<b>Enclosure - Base Electrical Panel</b>			
18	1	37094	FRONT FRAME & PANEL ASSEMBLY
19	1	37098	PANEL: TOP
20	1	37097	PANEL, LEFT REAR
21	1	37081	COVER: PIPE 1"
22	1	37101	REAR PANEL: UPPER RIGHT
23	1	37102	ACCESS PANEL: RIGHT REAR
24	1	37104	RIGHT SIDE ZERO CLEARANCE PANEL
25	1	37103	LOWER PANEL: RIGHT REAR

Item #	Qty	Part #	Description
26	1	37096	FRONT DOOR PANEL ASSY
27	2	37099	PANEL, SIDE
28	1	37063	PANEL: REAR
29	5	59133	LATCH, COMPRESSION
30	2	34063	LEG: BASE
31	1	34061	BASE FORMED 26 X 40
33	1	30090	ELECTRICAL PANEL MOUNTING PLATE
<b>Gaskets / "O" Rings</b>			
35	1	GP-122537	GASKET: EXHAUST MANIFOLD TO COMBUSTION CHAMBER
36	2	GP-18899	GASKET: BURNER FLANGE
37	1	81198	GASKET: INTAKE MANIFOLD FLANGE
39	1	81048	GASKET: FLAME DETECTOR
40	2	81205	GASKET: HEAD
42	1	GP-123077	UPPER HEAD LINER, COPPER
43	1	81160	GASKET: BLOWER OUTLET
44	1	81057	GASKET: BLOWER INLET
45	1	88003	O-RING #2-339 GAS INLET TO A/F VALVE
46	1	88004	O-RING #2-244, BLOWER INLET
<b>Controls</b>			
47	1	64099	POWER BOX ASSY - with SEQ VALVE
48	1	65085	TRANSFORMER: IGNITION
52	1	69158	I/O BOX WITH onAER with SEQ VALVE
53	1	65175	THERMOSTAT, JUMO
55	1	69126	LOW WATER CUT-OFF (LWCO) <b>Replacement Kit</b>
56	1	181197	C-MORE CONTROLLER
<b>Other Parts</b>			
60		24427-TAB	BAFFLE ASSEMBLY, in Heat Exchanger
61	1	89037	BAFFLE SEAL (component of item 60)
62	2	49274	BAFFLE SPACER STRIPS
64	1	80091	SHELL HEAD INSULATION
65	1	80090	SHELL INSULATION
70	1	92006-5	VALVE, 1" BALL
74	1	59039	6" WORM-DRIVE HOSE CLAMP
75	1	39125	ADAPTER: AIR INLET 6" (15.2 cm) PVC
77	1	97005-48	TUBE, FLEXIBLE GAS, 48" (121 cm)
78	1	61034	CURRENT TRANSDUCER (SPARK MONITOR)
81	1	80088	EXHAUST MANIFOLD SEAL
82	1	80087	PIPE SEAL

❶ Not shown on drawings below

AERCO International, Inc. Blauvelt, NY 10913	<b>Innovation Parts List</b>	12/31/2016
	<b>INN600/800/1060 29184-TAB INN1400 29293</b>	Page 1 of 5

# Innovation Installation, Operation & Maintenance – KOREA EDITION

## APPENDIX E – PARTS LIST DRAWINGS

### Wiring Harnesses (not shown in figures below)

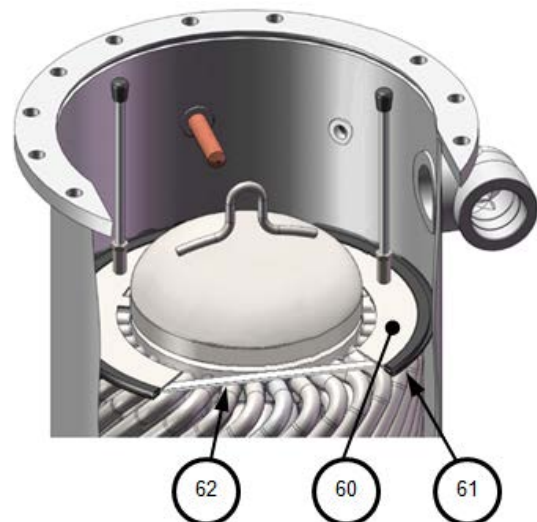
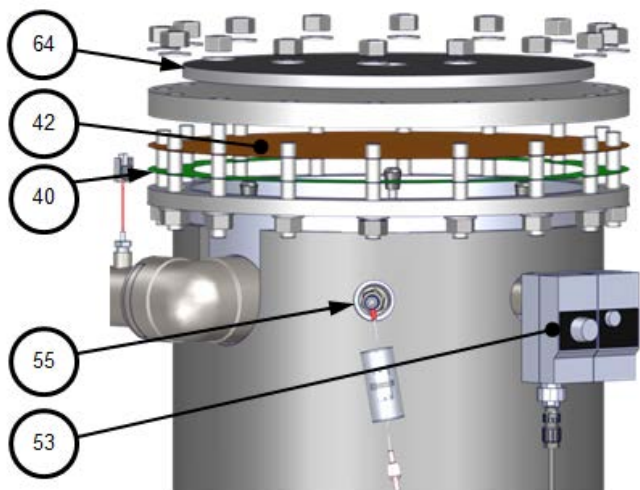
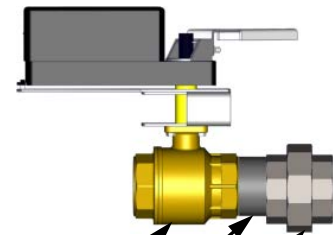
Part #	Description
63038	HARNESS: BLOWER
63143	HARNESS: SHELL WIRING, INN 1400
63072	HARNESS: SHELL WIRING, INN 600/800/1060
63079	HARNESS: INNOVATION CONTROL
63147	HARNESS: GAS TRAIN MAIN WIRING
63118	IGNITER GROUND WIRE ASSY.
63214	HARNESS: VALVE PROVING WIRING
65146	H.V IGNITION CABLE ASSEMBLY

### Available Replacement Kits

Part #	Description
24311-3	INN 600/800/1060 A/F VALVE
24311-4	INN 1400 A/F VALVE
58039	BLOWER
24335-1	LOW NOX BURNER ASSY
24336-TAB	PLATED HEAT EXCHANGER

### Other Accessories / Parts

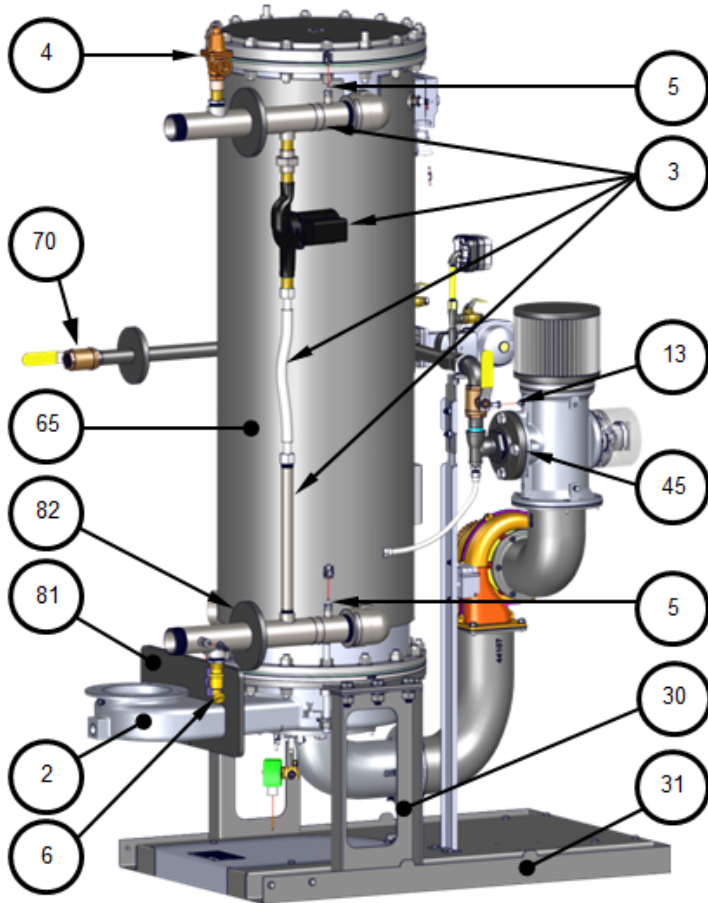
Part #	Description
24441	CONDENSATE TRAP ASSY.
92123	2" DOMESTIC WATER MOTORIZED SEQUENCING VALVE
90046-3	NIPPLE: 2" NPT 304 SS
93100	UNION: 2" NPT 304 STAINLESS



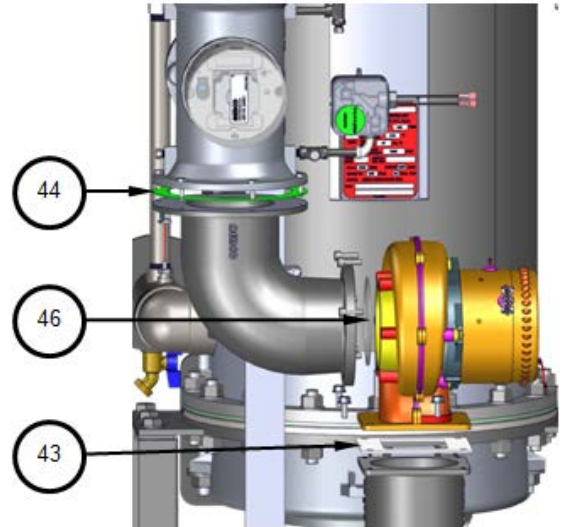
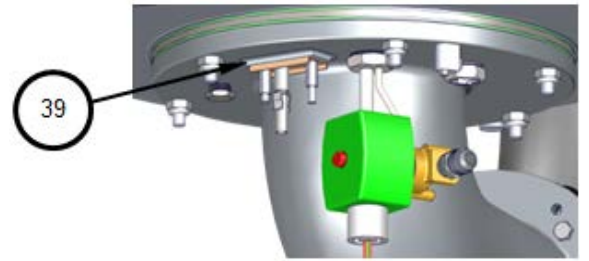
AERCO International, Inc. Blauvelt, NY 10913	<b>Innovation Parts List</b>	12/31/2016
	<b>INN600/800/1060 29184-TAB INN1400 29293</b>	Page 2 of 5

# Innovation Installation, Operation & Maintenance – KOREA EDITION

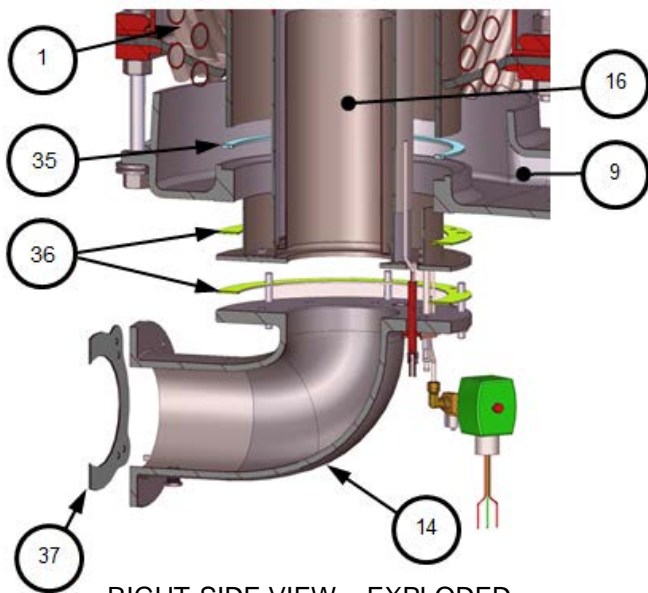
## APPENDIX E – PARTS LIST DRAWINGS



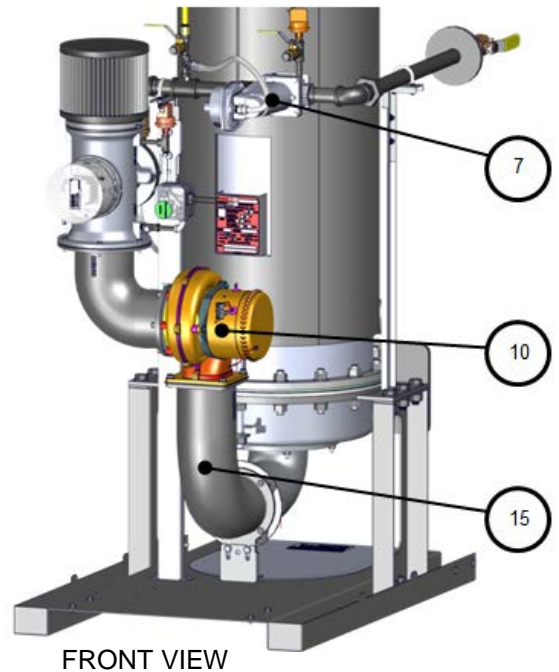
INN 600/800/1060 PICTURED



PARTIAL FRONT VIEW – EXPLODED



RIGHT-SIDE VIEW – EXPLODED



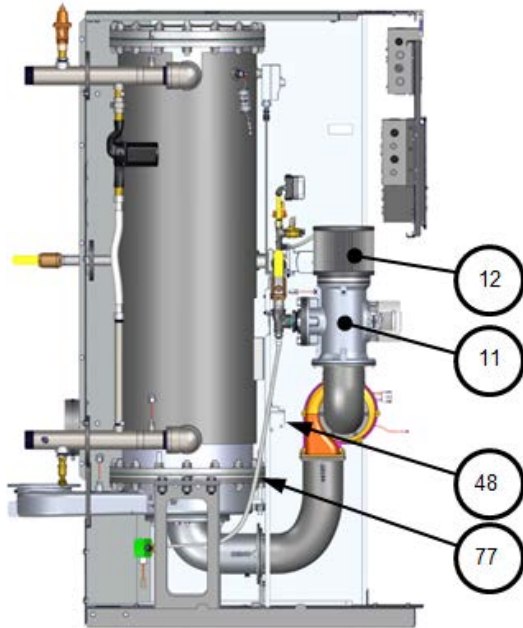
FRONT VIEW

AERCO International, Inc. Blauvelt, NY 10913	<b>Innovation Parts List</b>	12/31/2016
	<b>INN600/800/1060 29184-TAB INN1400 29293</b>	Page 3 of 5

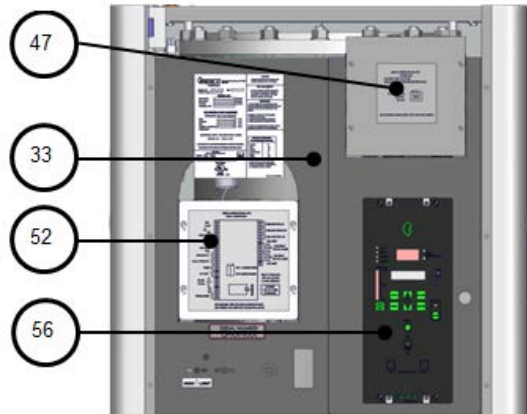


# Innovation Installation, Operation & Maintenance – KOREA EDITION

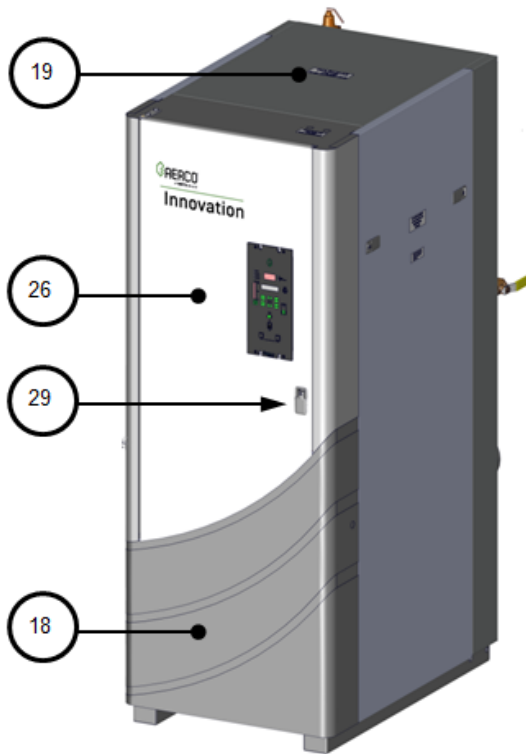
## APPENDIX E – PARTS LIST DRAWINGS



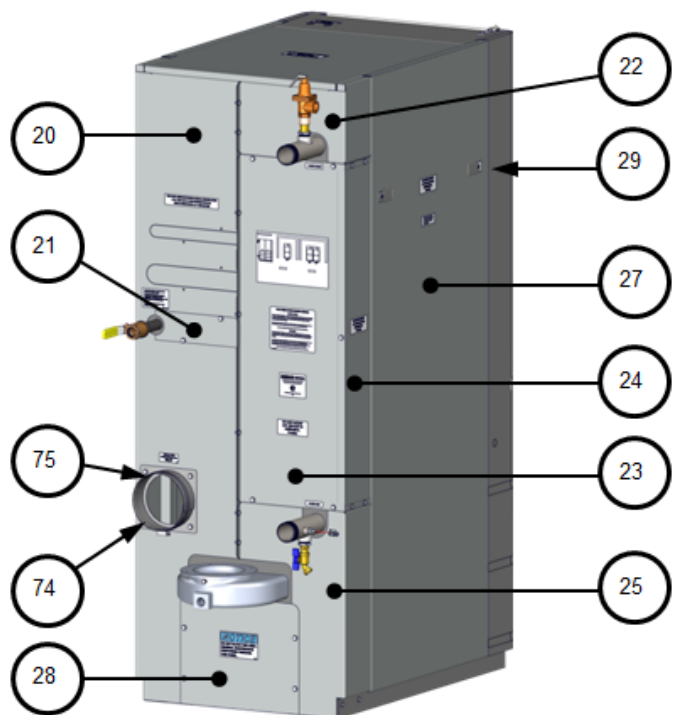
LEFT SIDE VIEW



PARTIAL FRONT VIEW



RIGHT-FRONT VIEW



LEFT-REAR VIEW

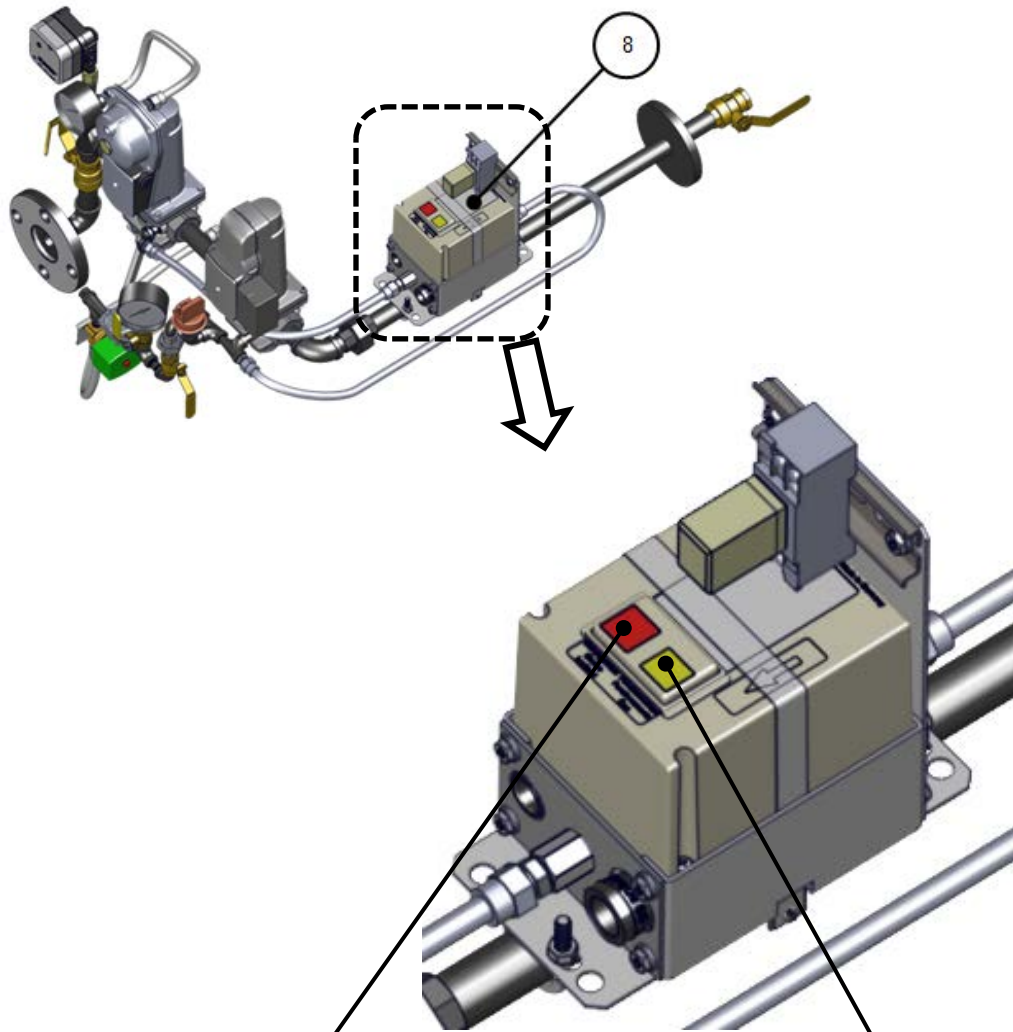
AERCO International, Inc. Blauvelt, NY 10913	<b>Innovation Parts List</b>	12/31/2016
	<b>INN600/800/1060 29184-TAB INN1400 29293</b>	Page 4 of 5

# Innovation Installation, Operation & Maintenance – KOREA EDITION

## APPENDIX E – PARTS LIST DRAWINGS

The Innovation 1400 gas trains P/N 22141-1 and 22141-4 includes a Valve Proving device. This device monitors the gas pressure on both sides of the Actuator. If the pressure difference falls below a fixed value, indicating the failure of the Actuator or leakage in the gas line, it triggers the shutdown of the unit. When this occurs, a **SSOV SWITCH OPEN** message appears in the C-More display.

Once the problem has been diagnosed and corrected, the Valve Proving device must be reset. This is done by pressing the red **RESET** switch before the unit is restarted; the C-More Controller must also be reset.



### RED ALARM LIGHT & RESET SWITCH

- **OFF** during normal operation
- **ON** indicates a leak or Actuator failure

### YELLOW RUN LIGHT

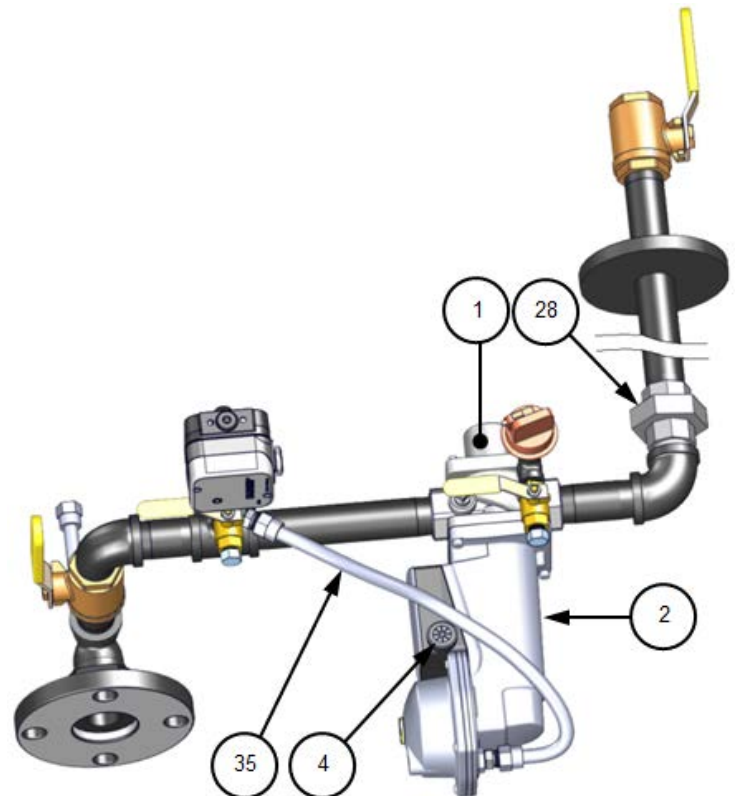
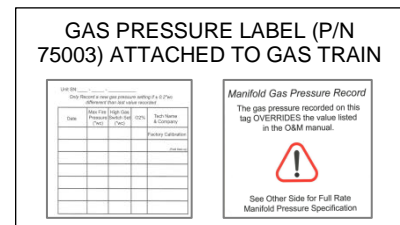
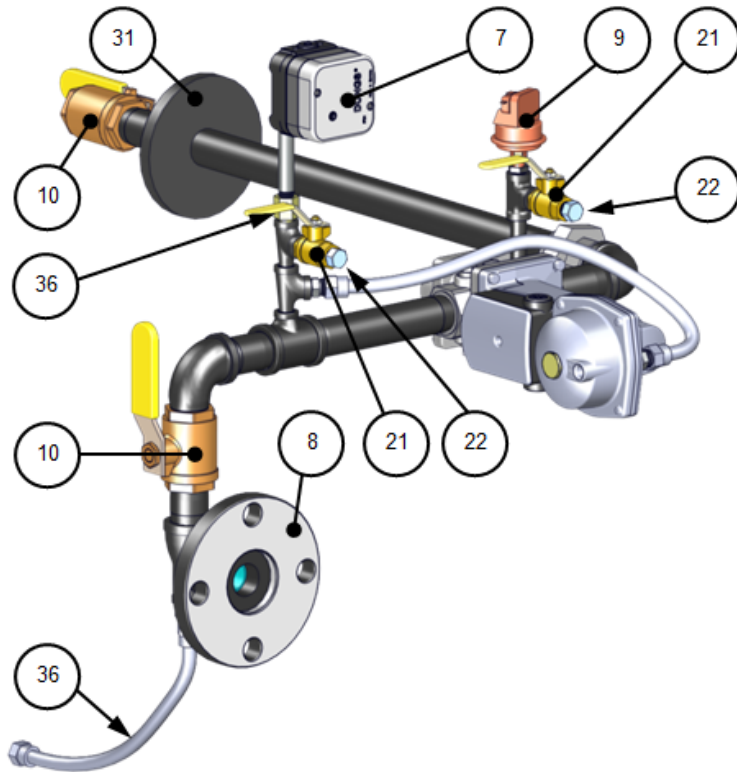
- **OFF** during normal operation
- **ON** during valve proving operation
- **ON** when the unit is in standby

AERCO International, Inc. Blauvelt, NY 10913	<b>Innovation Parts List</b>	12/31/2016
	<b>INN600/800/1060 29184-TAB INN1400 29293</b>	Page 5 of 5

# Innovation Installation, Operation & Maintenance – KOREA EDITION

## APPENDIX E – PARTS LIST DRAWINGS

Innovation 600-800-1060 Gas Train – P/N 22122							
Item	Qty	Part #	Description	Item	Qty	Part #	Description
1	1	92036	VALVE: SSOV 1" NPT	21	2	92077	1/4" NPT MXF BRASS BALL VALVE
2	1	64048	ACTUATOR: SSOV W/ REGULATOR	22	2	9-22	PIPE PLUG: 1/4" NPT: STEEL
4	2	12951-2	BUSHING: CONTROL BOX	28	1	123771	UNION: MA x FEM 1" NPT: 150# M.I.
7	1	60032	SWITCH: GAS PRESSURE 2-20" W.C.	30	1	99017	SNUBBER: PRESSURE: 1/4"
8	1	123542	FLANGE 2" 125# 2" NPT	31	1	80087-2	INNOVATION ENCLOSURE PIPE SEAL
9	1	61002-1	PRESSURE SWITCH: 2.6" W.C. FALL N.O.	35	1	97087-16	TUBE: 3/8 OD FLARED FLEX GAS - 16"
10	2	92006-5	VALVE: BALL 1" NPT	36	1	97087-36	TUBE: 3/8 OD FLARED FLEX GAS - 36"



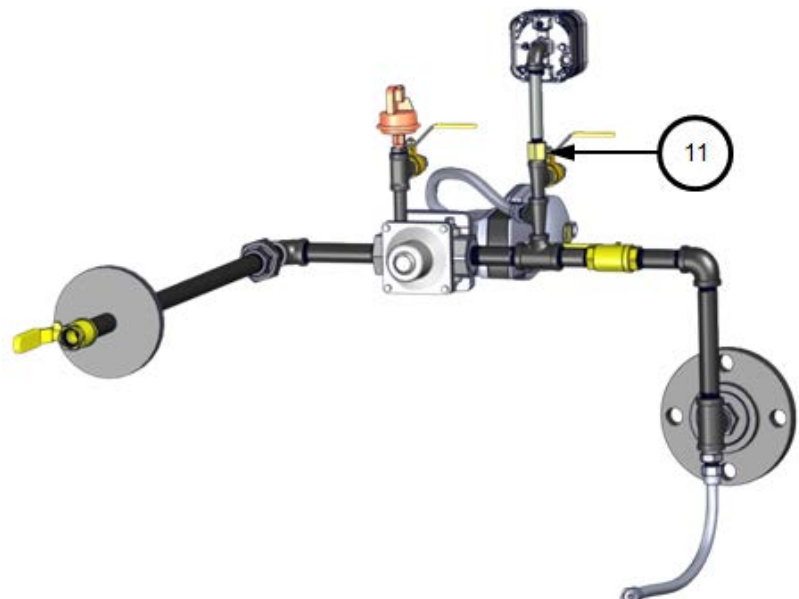
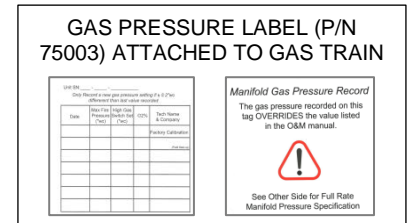
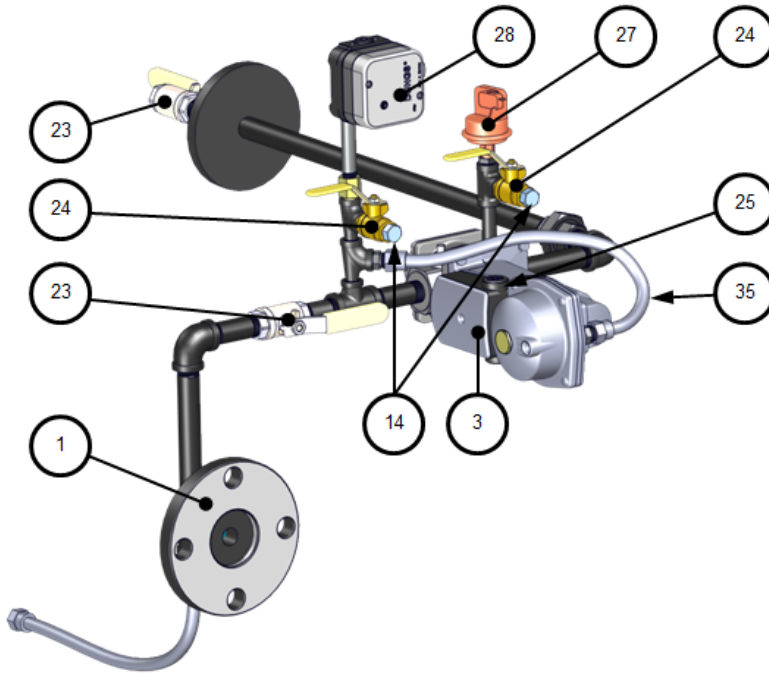
AERCO International, Inc. Blauvelt, NY 10913	<b>Innovation 600-800-1060 1" Gas Train</b>	04/12/2017
	<b>22122 rev M</b>	Sheet 1 of 1



# Innovation Installation, Operation & Maintenance – KOREA EDITION

## APPENDIX E – PARTS LIST DRAWINGS

Innovation 600P-800P 1/2" PROPANE Gas Train – P/N 22179							
Item	Qty	Part #	Description	Item	Qty	Part #	Description
1	1	123542	FLANGE 2" 125# 2"NPT	24	2	92077	1/4" NPT MXF BRASS BALL VALVE (OPEN)
2	1	92103	VALVE: SSOV 1/2" NPT	25	2	12951-2	BUSHING: CONTROL BOX
3	1	64048	ACTUATOR: SSOV W/ REGULATOR	27	1	61002-8	LOW GAS PRESSURE SWITCH 4.4" W.C.
9	1	93420	UNION 1/2" NPT FEMALE BLACK MI	28	1	60032	SWITCH ASSEMBLY: GAS PRESSURE 2-20 WC
11	1	99017	SNUBBER, 1/4"	31	1	80087-0	INNOVATION ENCLOSURE PIPE SEAL
14	2	9-22	PIPE PLUG: 1/4" NPT: STEEL	35	1	97087-16	TUBE: 3/8 OD FLARED FLEX GAS -16"
23	2	92006-3	VALVE: FULL PORT BALL 1/2" NPT BRASS	36	1	97087-36	TUBE: 3/8 OD FLARED FLEX GAS - 36"

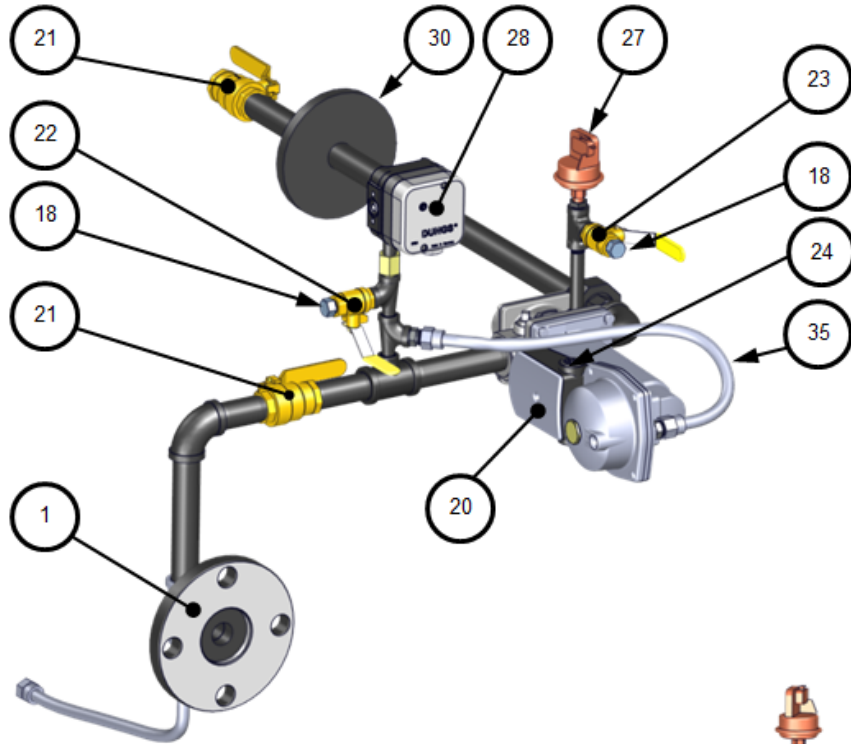


AERCO International, Inc. Blauvelt, NY 10913	<b>Innovation 600P-800P PROPANE Gas Train</b>	04/11/2017
	<b>22179 rev J</b>	Sheet 1 of 1

# Innovation Installation, Operation & Maintenance – KOREA EDITION

## APPENDIX E – PARTS LIST DRAWINGS

Innovation 1060P 3/4" PROPANE Gas Train – P/N 22180							
Item	Qty	Part #	Description	Item	Qty	Part #	Description
1	1	123542	FLANGE 2" 125# 2" NPT	23	2	12951-2	BUSHING: CONTROL BOX
6	1	5016	UNION: 3/4" NPT MALE-FEMALE 150#	26	1	61002-8	LOW GAS PRESSURE SWITCH 4.4" W.C.
18	2	9-22	PIPE PLUG: 1/4" NPT: STEEL	27	1	60032	HIGH GAS PRESSURE SWITCH 2-20" W.C.
19	1	92101	VALVE: SSOV 3/4" NPT	28	1	80087-1	INNOVATION ENCLOSURE PIPE SEAL
20	1	64048	ACTUATOR: SSOV W/ REGULATOR	32	1	97087-36	TUBE: 3/8 OD FLARED FLEX GAS- 36"
21	2	92006-4	VALVE: FULL PORT BALL 3/4" NPT	33	1	97087-16	TUBE: 3/8 OD FLARED FLEX GAS- 16"
22	2	92077	1/4" NPT MXF BRASS BALL VALVE				

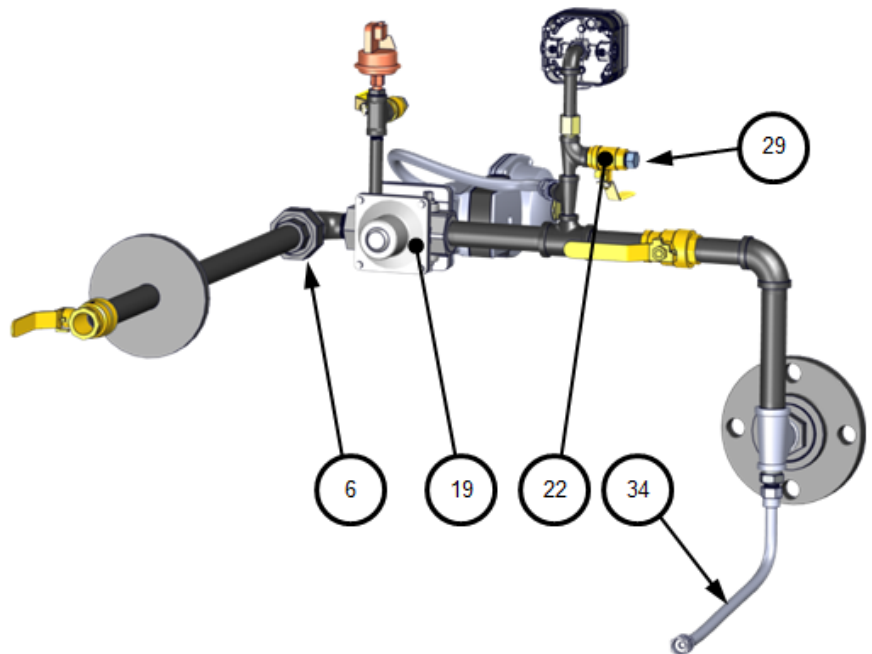


**GAS PRESSURE LABEL (P/N 75003) ATTACHED TO GAS TRAIN**

<small>NOTE: Only Record on new gas pressure setting (1.0 PSI) otherwise record for each revision.</small>			
Date	Time	Pressure (PSI)	Initials & Company

**Manifold Gas Pressure Record**  
The gas pressure recorded on this tag OVERRIDES the value listed in the O&M manual.

See Other Side for Full Rate Manifold Pressure Specification

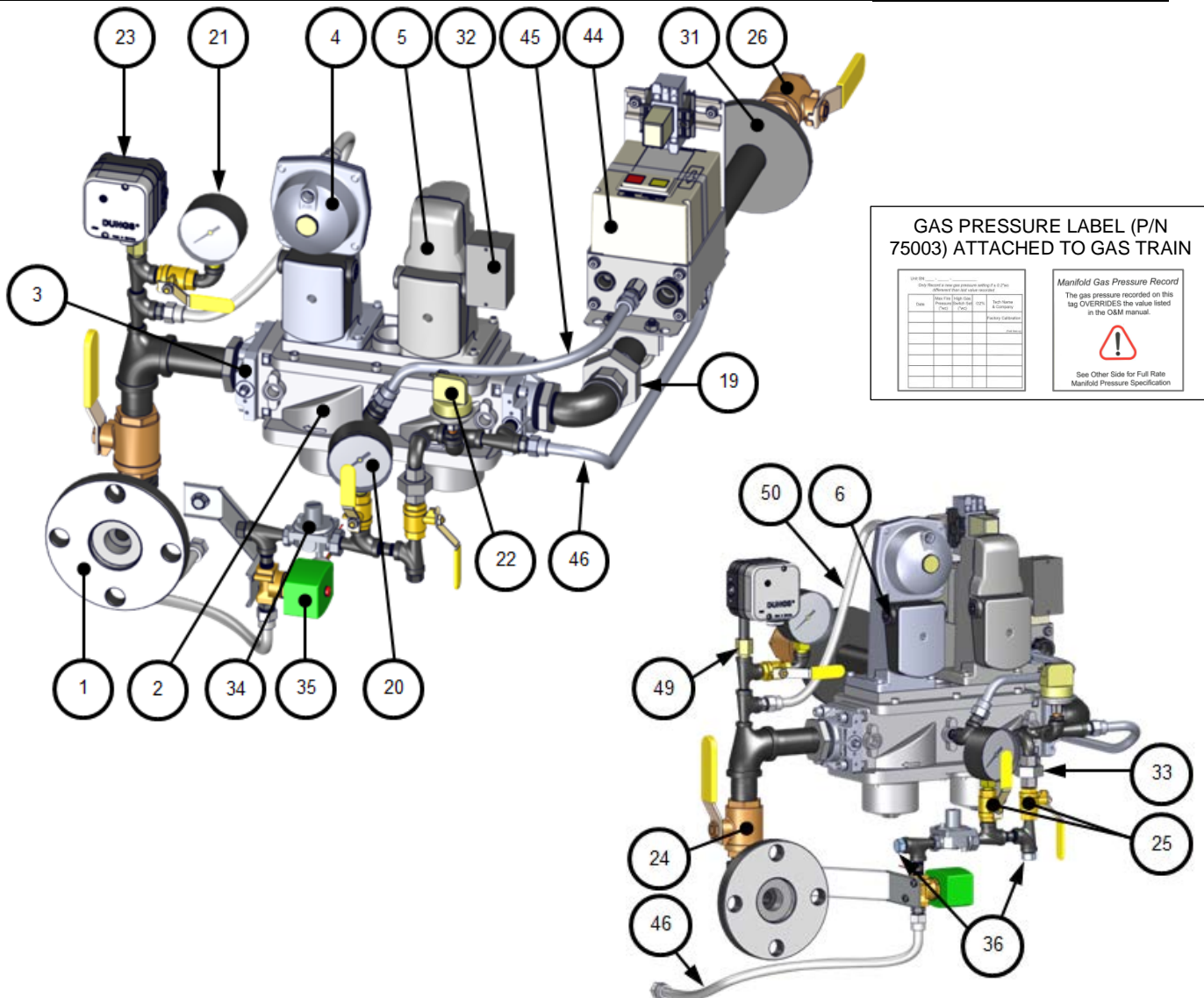


AERCO International, Inc. Blauvelt, NY 10913	<b>Innovation 1060P PROPANE Gas Train</b>	04/12/2016
	<b>22180 rev J</b>	Sheet 1 of 1

# Innovation Installation, Operation & Maintenance – KOREA EDITION

## APPENDIX E – PARTS LIST DRAWINGS

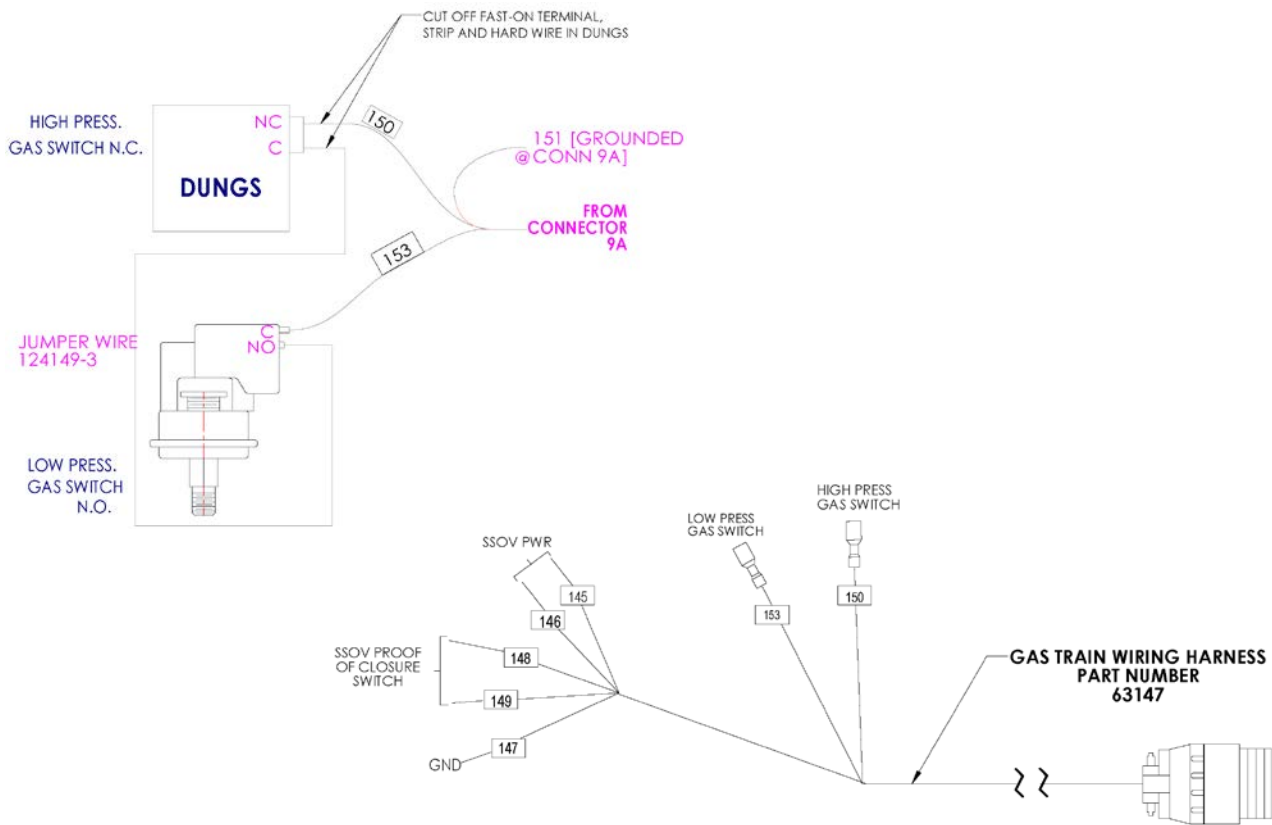
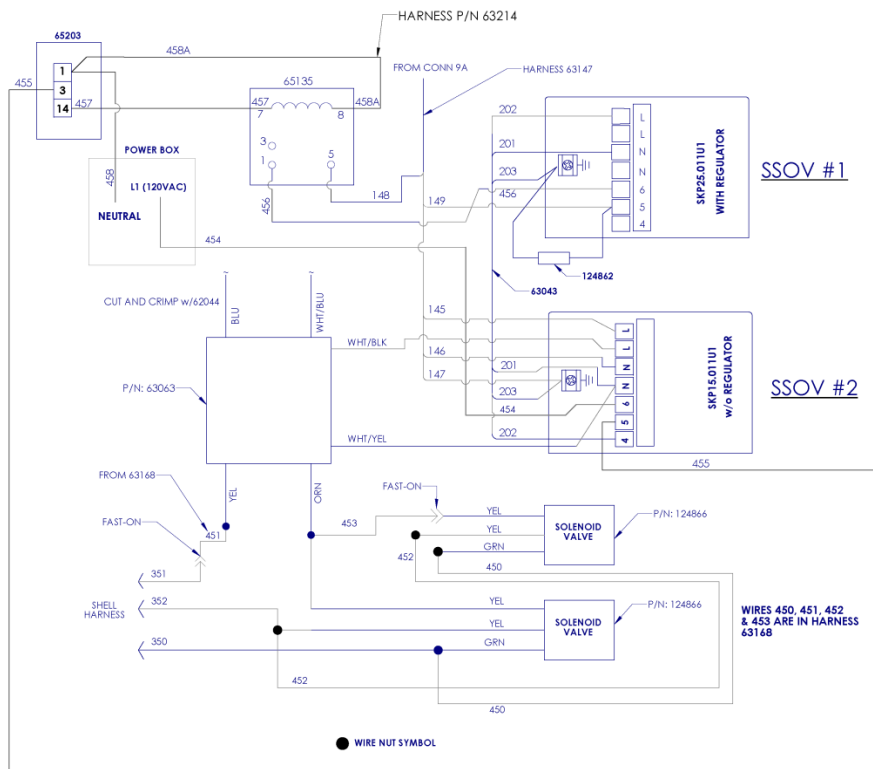
Innovation 1400 1" (2.54 cm) Gas Train – P/N 22182-1							
Item	Qty	Part #	Description	Item	Qty	Part #	Description
1	1	123542	FLANGE 2" 125# 2" NPT	25	3	92077	1/4" NPT MXF BRASS BALL VALVE
2	1	124137	VALVE: SSOV: DOUBLE BODY: 1-1/2" NPT	31	1	80087-2	INNOVATION ENCLOSURE PIPE SEAL
3	2	95029	FLANGE: SSOV 1 1/2" NPT	32	1	63063	RELAY
4	1	64048	ACTUATOR: SSOV W/ REGULATOR	33	1	124933	UNION: 1/4" NPT
5	1	27086-2	ACTUATOR: SSOV	34	1	64083	REGULATOR: GAS PRESSURE WITH VENT LIMITING ORIFICE
6	4	12951-2	BUSHING, CONTROL BOX	35	1	124866	SOLENOID VALVE: 1/4" NPT
19	1	123771	UNION: MA x FEM 1" NPT: 150# M.I.	36	2	9-22	PIPE PLUG: 1/4" NPT: STEEL
20	1	67007	GAGE: LOW PRESSURE 0-15 in./H2O	44	1	24269-1	VALVE PROVING SYSTEM ASSEMBLY
21	1	67006	GAGE: LOW PRESSURE 0-10 in./H2O	45	2	97087-16	TUBE: FLEXIBLE GAS 16" (40.6 cm)
22	1	61002-1	LOW PRESSURE SWITCH: 2.6" W.C. FALL N.O.	46	2	97087-36	TUBE: 3/8 OD FLARED FLEX GAS 36" (91.4 cm)
23	1	60032	HIGH GAS PRESSURE SWITCH 1-20" W.C.	49	1	99017	SNUBBER, PRESSURE, 1/4"
24	2	92006-5	VALVE: BALL 1" NPT				



AERCO International, Inc. Blauvelt, NY 10913	<b>Innovation 1400 1" Natural Gas Gas Train</b>  <b>22182-1 rev H</b>	04/17/2017  Sheet 1 of 2
----------------------------------------------------	-----------------------------------------------------------------------------	--------------------------------

# Innovation Installation, Operation & Maintenance – KOREA EDITION

## APPENDIX E – PARTS LIST DRAWINGS

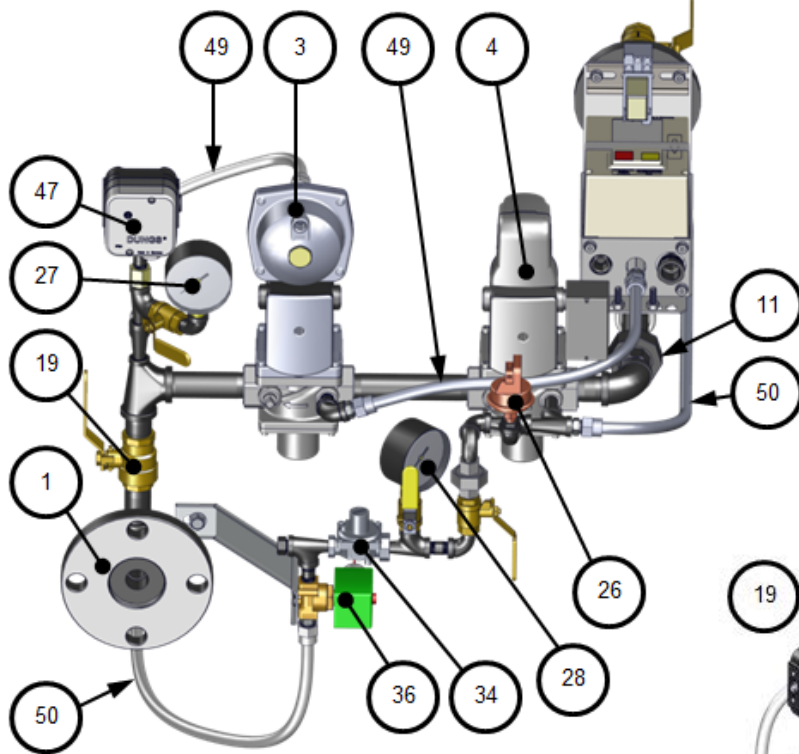


AERCO International, Inc. Blauvelt, NY 10913	<b>Innovation 1400 1" Natural Gas Gas Train</b>	04/17/2017
<b>22182-1 rev H</b>		Sheet 2 of 2

# Innovation Installation, Operation & Maintenance – KOREA EDITION

## APPENDIX E – PARTS LIST DRAWINGS

Innovation 1400P 3/4" PROPANE DB Gas Train – P/N 22182-4							
Item	Qty	Part #	Description	Item	Qty	Part #	Description
1	1	123542	FLANGE 2" 125# 2" NPT	31	1	124933	UNION: 1/4" NPT
2	2	92101	VALVE: SSOV 3/4" NPT	33	1	63063	RELAY
3	1	64048	ACTUATOR: SSOV W/ REGULATOR	34	1	64083	REGULATOR: GAS PRESSURE WITH VENT LIMITING ORIFICE
4	1	124138	ACTUATOR: SSOV	35	1	9-22	PIPE PLUG: 1/4" NPT: STEEL
11	1	5016	UNION: 3/4" NPT MALE-FEMALE 150#	36	1	124866	SOLENOID VALVE: 1/4" NPT
19	2	92006-4	VALVE: FULL PORT BALL 3/4" NPT	44	1	24629-4	VALVE PROVING SYSTEM ASSEMBLY
20	3	92077	1/4" NPT MXF BRASS BALL VALVE	45	1	99017	SNUBBER
26	1	61002-8	LOW GAS PRESSURE SWITCH 4.4" W.C.	47	1	60032	SWITCH: GAS PRESSURE 2-20" W.C.
27	1	67006	GAGE: LOW PRESSURE 0-10 in./H2O	49	2	97087-16	TUBE: 3/8 OD FLARED FLEX GAS - 16"
28	1	67007	GAGE: LOW PRESSURE 0-15 in./H2O	50	2	97087-36	TUBE: 3/8 OD FLARED FLEX GAS - 36"
30	1	80087-1	INNOVATION ENCLOSURE PIPE SEAL				

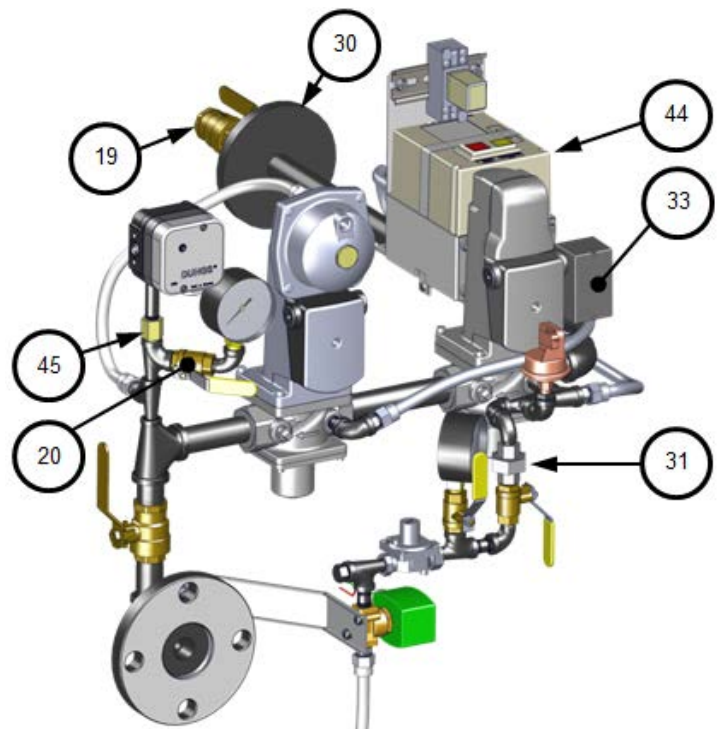


**GAS PRESSURE LABEL (P/N 75003) ATTACHED TO GAS TRAIN**

Date	Manifold Gas Pressure (PSI)	Manifold Gas Pressure (in. H <sub>2</sub> O)	Technician Name	Company

**Manifold Gas Pressure Record**  
The gas pressure recorded on this tag **OVERRIDES** the value listed in the O&M manual.

See Other Side for Full Rate Manifold Pressure Specification

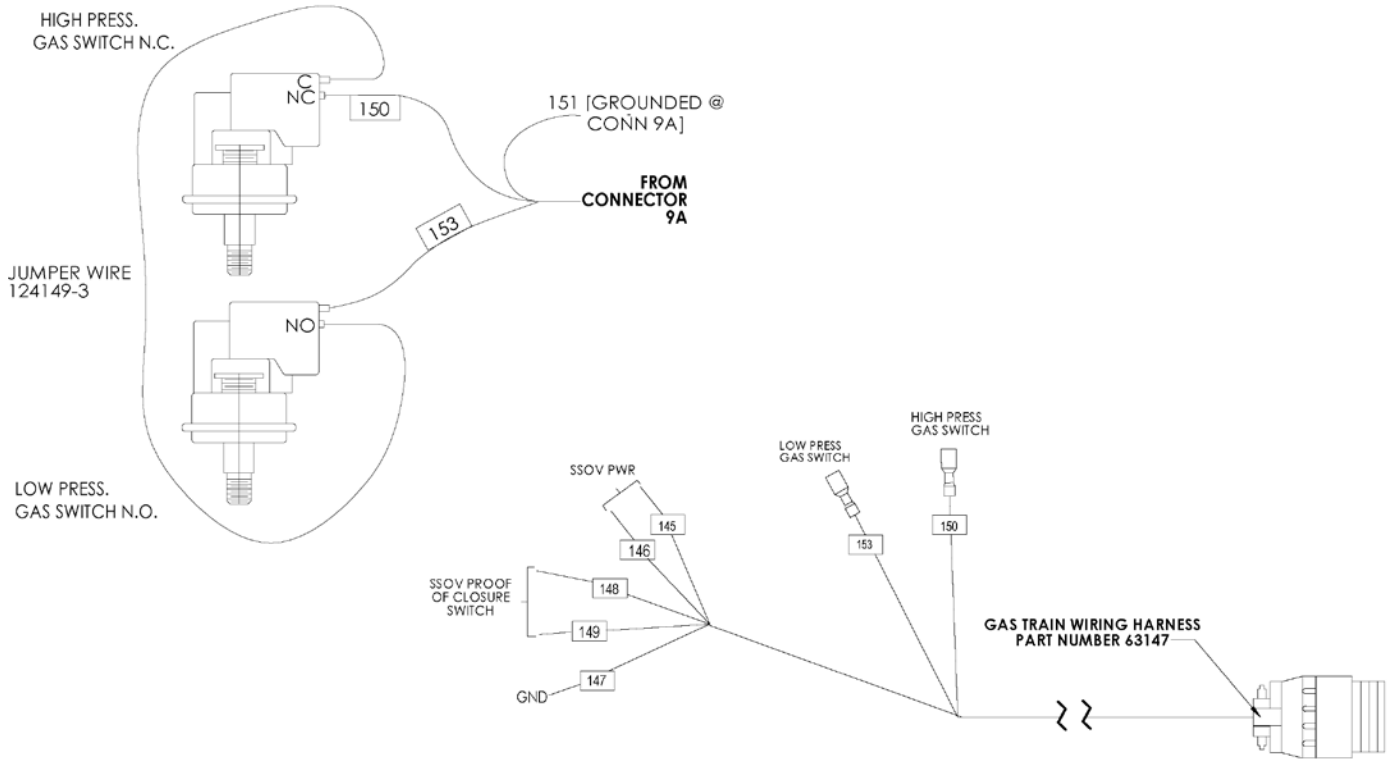
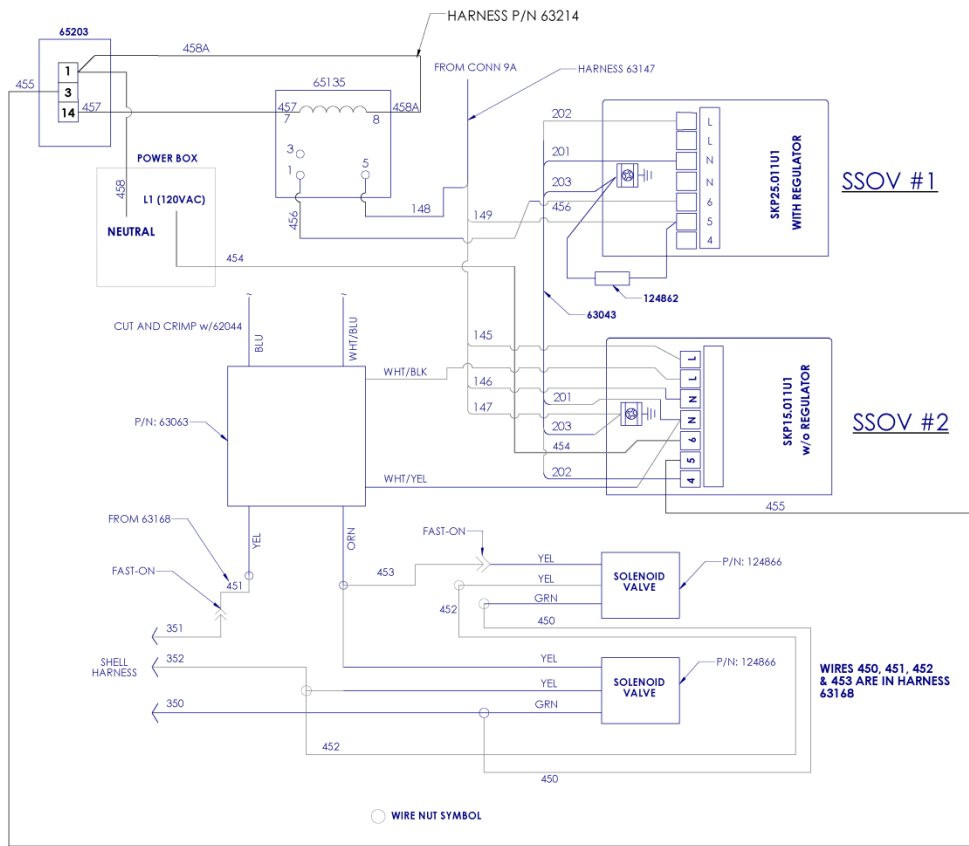


AERCO International, Inc. Blauvelt, NY 10913	<b>Innovation 1400P 3/4" PROPANE DB Gas Train</b>	04/18/2017
	<b>22182-4 rev F</b>	Sheet 1 of 2



# Innovation Installation, Operation & Maintenance – KOREA EDITION

## APPENDIX E – PARTS LIST DRAWINGS



AERCO International, Inc. Blauvelt, NY 10913	<b>Innovation 1400P 3/4" PROPANE DB Gas Train</b>	04/18/2017
	<b>22182-4 rev F</b>	Sheet 2 of 2





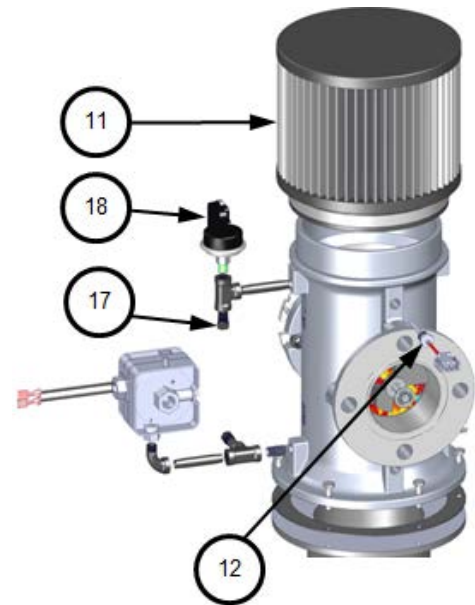
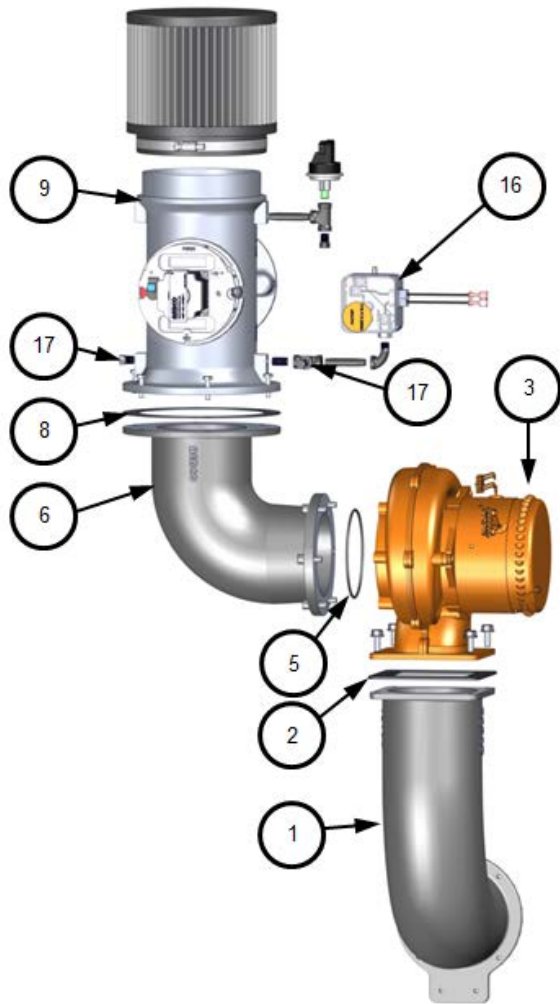
# Innovation Installation, Operation & Maintenance – KOREA EDITION

## APPENDIX E – PARTS LIST DRAWINGS

Innovation 1400 Air Fuel Delivery System – P/N 24346							
Item	Qty	Part #	Description	Item	Qty	Part #	Description
1	1	44107	BLOWER SIDE INTAKE MANIFOLD	9 ②	1	24220-4	A/F VALVE ASSY
2 ①	1	81160	GASKET: BLOWER	11	1	59138	AIR FILTER, 6" (15.2 cm)
3 ①	1	24111	BLOWER: AMETEK 8.9"	12	1	61024	AIR INLET TEMPERATURE SENSOR
5	1	88004	O-RING #2-244 BUNA-N	16	1	60011-4	BLOWER PROOF SWITCH ASSEMBLY
6	1	44108	BLOWER-A/F VALVE ADAPTER	17	3	9-21	PLUG: HEX 1/8 NPT
8 ①②	1	81057	GASKET: BLOWER	18	1	61002-5	BLOCKED INLET SWITCH -4.5" W.C.

① 81160, 24111 & 81057 are included in Blower Replacement Kit # 58039

② 81057, 24220-4 & 88003 'O'-Ring #2-339 (not shown) are included in A/F Valve Replacement kit: #24311-4



AERCO International, Inc. Blauvelt, NY 10913	<b>Innovation 1400 Air/Fuel Delivery System</b>	04/20/2016
	<b>24346 rev J</b>	Sheet 1 of 1

# Innovation Installation, Operation & Maintenance – KOREA EDITION

## APPENDIX E – PARTS LIST DRAWINGS

Intake Manifold Assembly P/N 24234			
Item	Qty	Part #	Description
1	1	44106	INTAKE MANIFOLD
2	1	59104	OBSERVATION PORT
3 ②	1	66026	IGNITER-INJECTOR
4 ①	1	81048	FLAME DETECTOR GASKET
5 ①	1	66037	FLAME DETECTOR
6	2	93358	PLUG 1/4 NPT HEX HD PIPE
7 ⑤	1	GP-18899	BURNER FLANGE GASKET
8	2	52037	STUD #10-32
9	2	59027	STANDOFF, THREADED #10-32
10 ②	3	53033	WASHER: CLOCKING
11	1	24247	STAGED IGNITION ASSEMBLY

Innovation Burner Assembly P/N 24233			
Item	Qty	Part #	Description
12	1	44179	BURNER PLATE
13	1	24233	BURNER SUB-ASSEMBLY
14	1	122977	TWO-WAY CONNECTOR
15	8	54117	SCREW, PAN HEAD 1/4-28

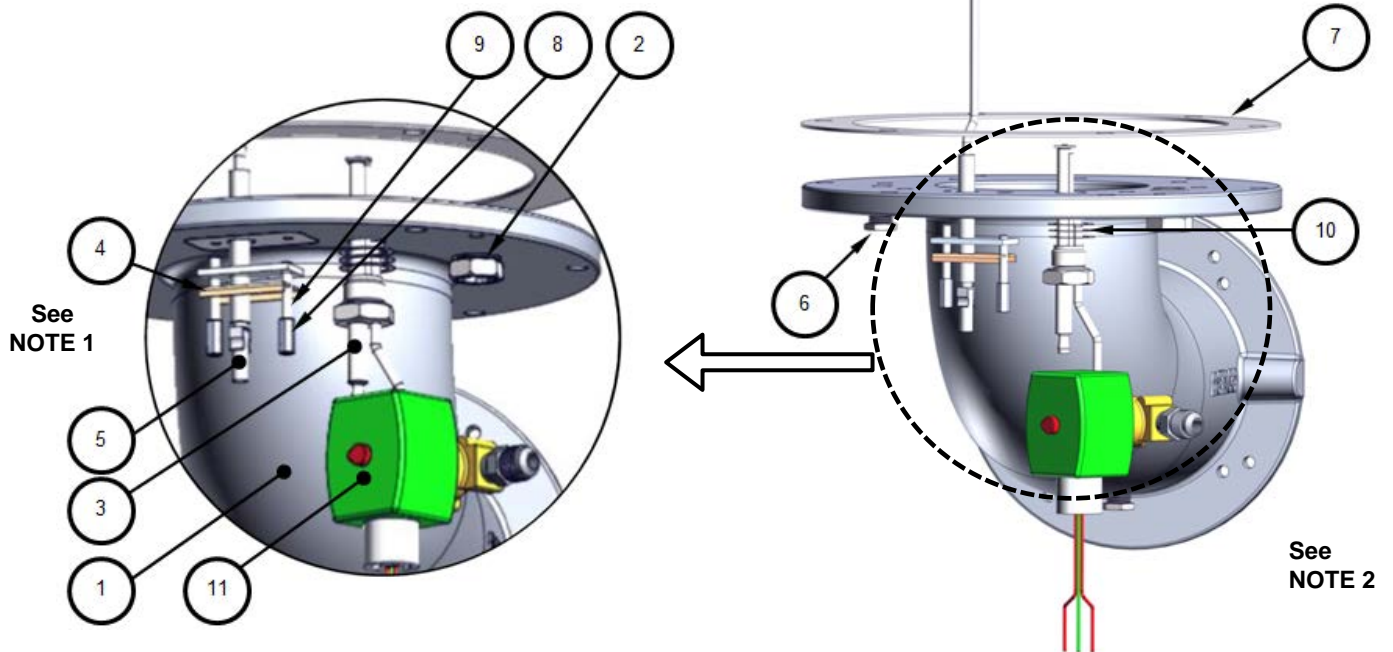
- ① 81048 & 66037 are supplied as kit # 24356-2
- ② 66026 & 53033 are supplied as kit #58023
- ⑤ GP-18899 is supplied as kit #24335-1

**NOTE 1:**

Apply Hi Temp conductive anti-seize Loctite C5-A prior to insertion & then torque to 170-180 In/lbs (19.2–20.3Nm)

**NOTE 2:**

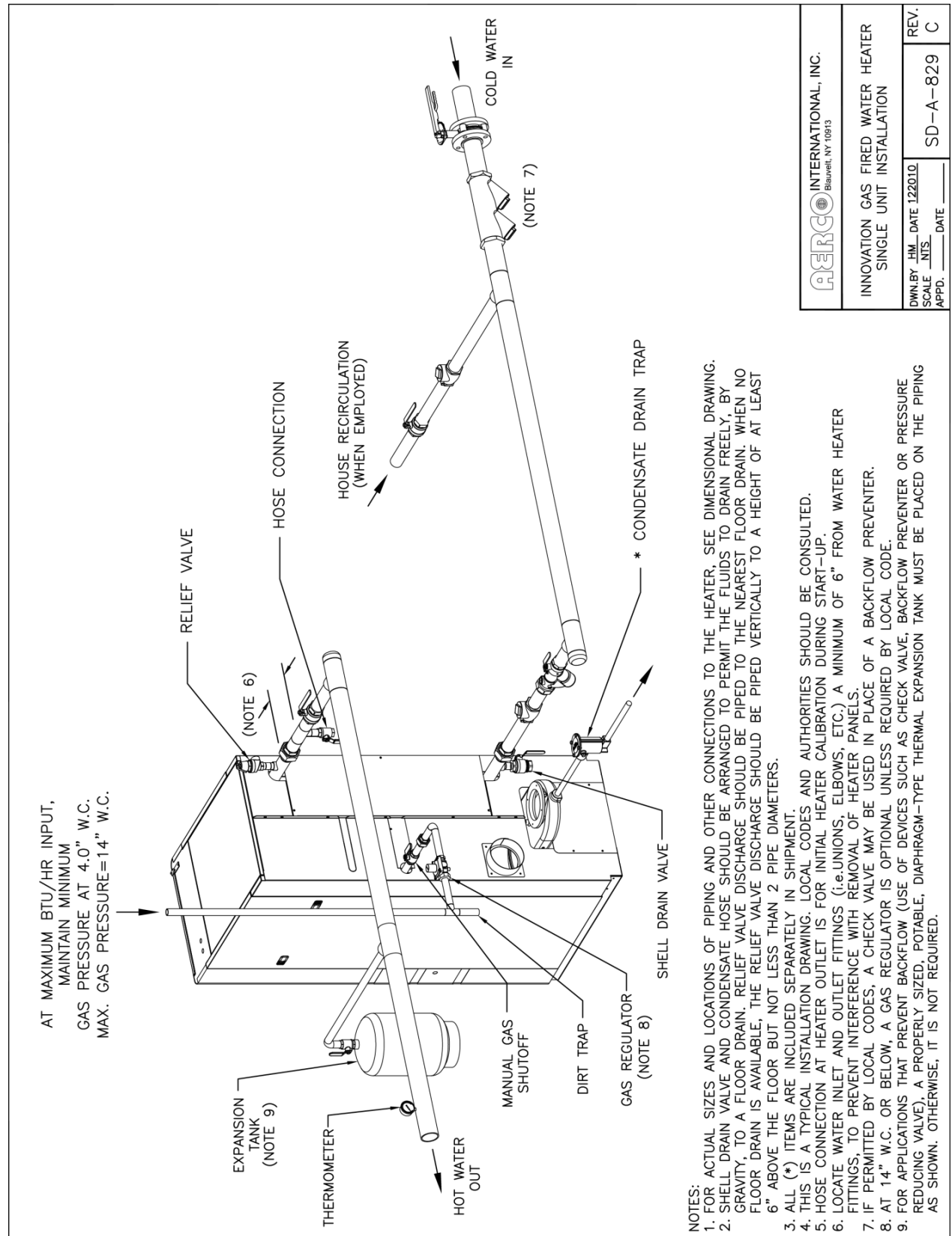
Use 3 or 4 “Clocking Washers” to establish correct orientation



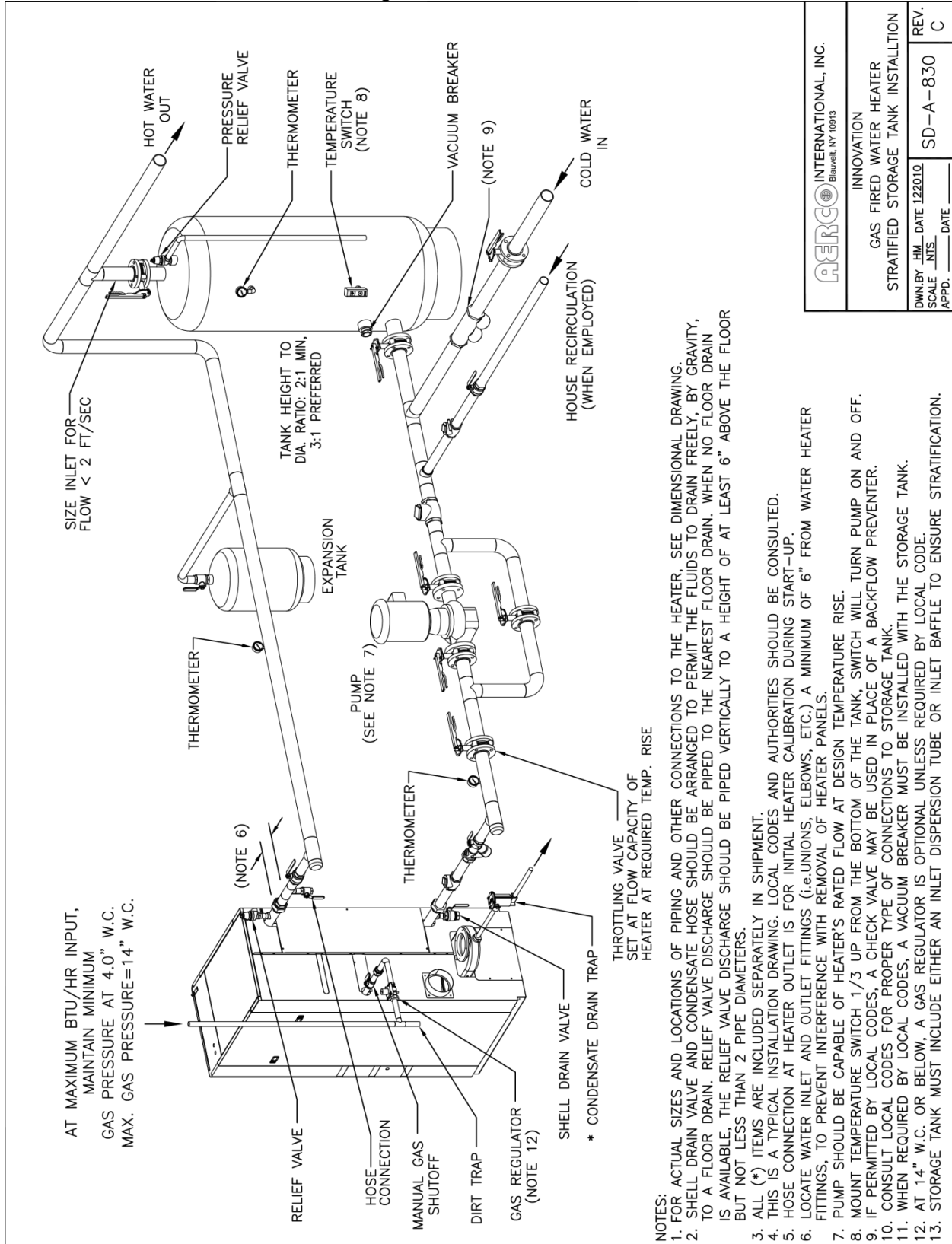
AERCO International, Inc. Blauvelt, NY 10913	Intake Manifold, Burner & Shield	08/24/2015
	24234 rev E, 24233 rev E	Sheet 1 of 1

(This Page Is Intentionally Blank)

APPENDIX F – Piping Drawings



Drawing Number: SD-A-829 rev C

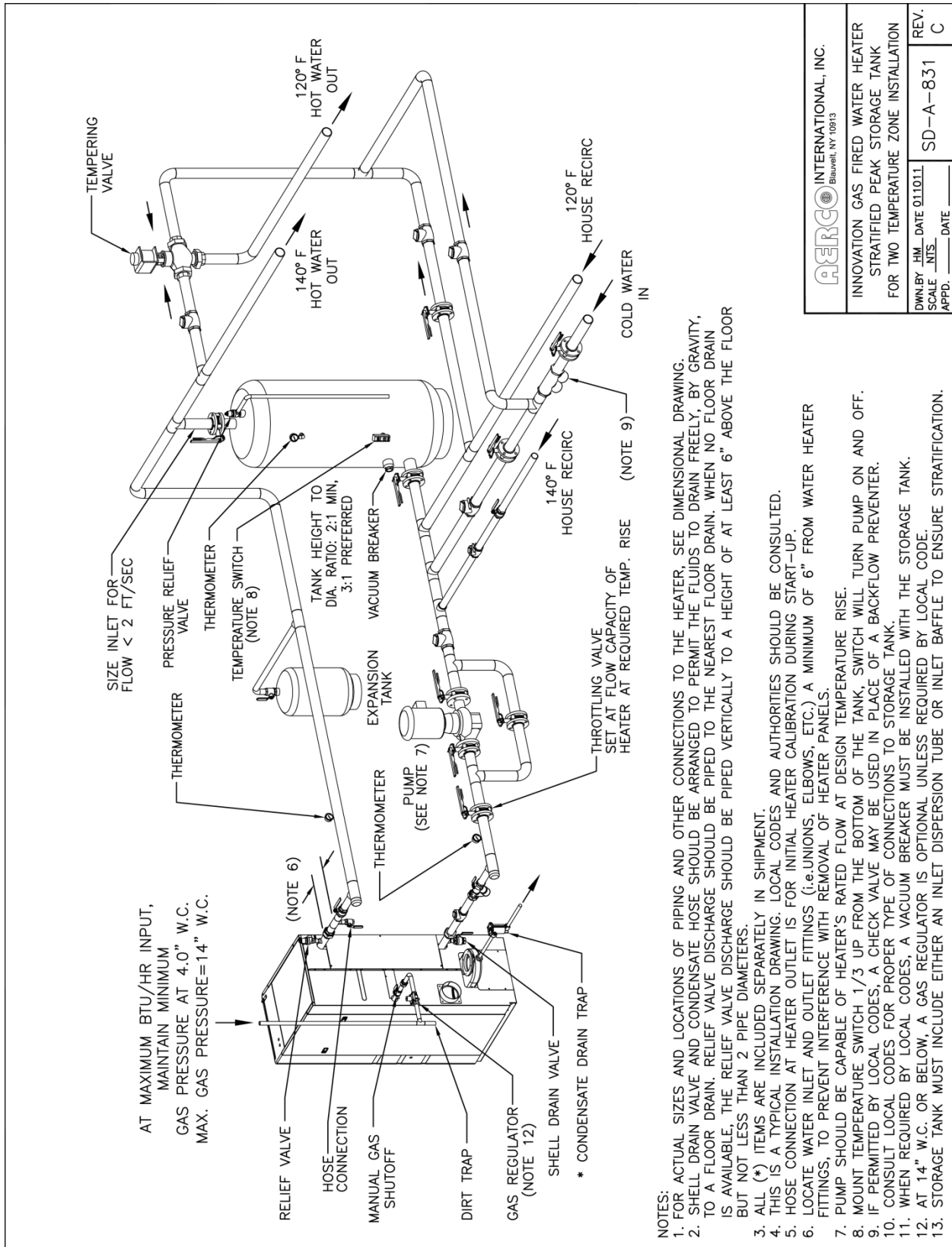


 Blauvelt, NY 10913	
INNOVATION GAS FIRED WATER HEATER STRATIFIED STORAGE TANK INSTALLATION	
DWN BY: <u>HM</u> DATE: <u>12/20/10</u> SCALE: <u>NIS</u> APPD: _____ DATE: _____	REV: <u>C</u> SD-A-830

- NOTES:
- FOR ACTUAL SIZES AND LOCATIONS OF PIPING AND OTHER CONNECTIONS TO THE HEATER, SEE DIMENSIONAL DRAWING.
  - SHELL DRAIN VALVE AND CONDENSATE HOSE SHOULD BE ARRANGED TO PERMIT THE FLUIDS TO DRAIN FREELY, BY GRAVITY, TO A FLOOR DRAIN. RELIEF VALVE DISCHARGE SHOULD BE PIPED TO THE NEAREST FLOOR DRAIN. WHEN NO FLOOR DRAIN IS AVAILABLE, THE RELIEF VALVE DISCHARGE SHOULD BE PIPED VERTICALLY TO A HEIGHT OF AT LEAST 6" ABOVE THE FLOOR BUT NOT LESS THAN 2 PIPE DIAMETERS.
  - ALL (\*) ITEMS ARE INCLUDED SEPARATELY IN SHIPMENT.
  - THIS IS A TYPICAL INSTALLATION DRAWING. LOCAL CODES AND AUTHORITIES SHOULD BE CONSULTED.
  - HOSE CONNECTION AT HEATER OUTLET IS FOR INITIAL HEATER CALIBRATION DURING START-UP.
  - LOCATE WATER INLET AND OUTLET FITTINGS (i.e. UNIONS, ELBOWS, ETC.) A MINIMUM OF 6" FROM WATER HEATER FITTINGS, TO PREVENT INTERFERENCE WITH REMOVAL OF HEATER PANELS.
  - PUMP SHOULD BE CAPABLE OF HEATER'S RATED FLOW AT DESIGN TEMPERATURE RISE.
  - MOUNT TEMPERATURE SWITCH 1/3 UP FROM THE BOTTOM OF THE TANK. SWITCH WILL TURN PUMP ON AND OFF.
  - IF PERMITTED BY LOCAL CODES, A CHECK VALVE MAY BE USED IN PLACE OF A BACKFLOW PREVENTER.
  - CONSULT LOCAL CODES FOR PROPER TYPE OF CONNECTIONS TO STORAGE TANK.
  - WHEN REQUIRED BY LOCAL CODES, A VACUUM BREAKER MUST BE INSTALLED WITH THE STORAGE TANK.
  - AT 14" W.C. OR BELOW, A GAS REGULATOR IS OPTIONAL UNLESS REQUIRED BY LOCAL CODE.
  - STORAGE TANK MUST INCLUDE EITHER AN INLET DISPERSION TUBE OR INLET BAFFLE TO ENSURE STRATIFICATION.

Drawing Number: SD-A-830 rev C



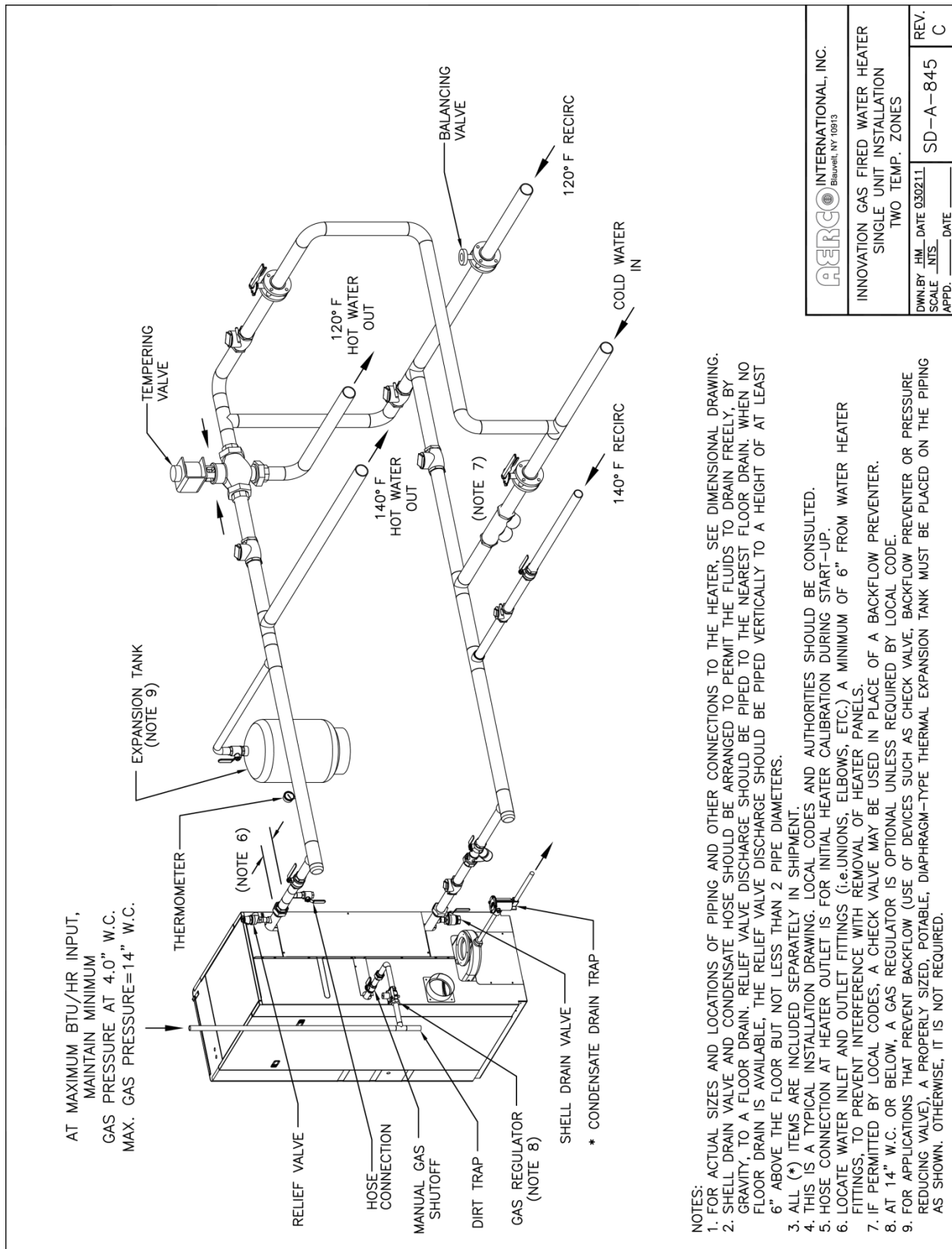


 Blauvelt, NY 10913	
INNOVATION GAS FIRED WATER HEATER STRATIFIED PEAK STORAGE TANK FOR TWO TEMPERATURE ZONE INSTALLATION	
DWN. BY <u>          </u> DATE <u>01/01/11</u>	REV. <u>          </u>
SCALE <u>          </u>	SD-A-831 DATE <u>          </u>

Drawing Number: SD-A-831 rev C

# Innovation Installation, Operation & Maintenance – KOREA EDITION

## APPENDIX F – PIPING DRAWINGS



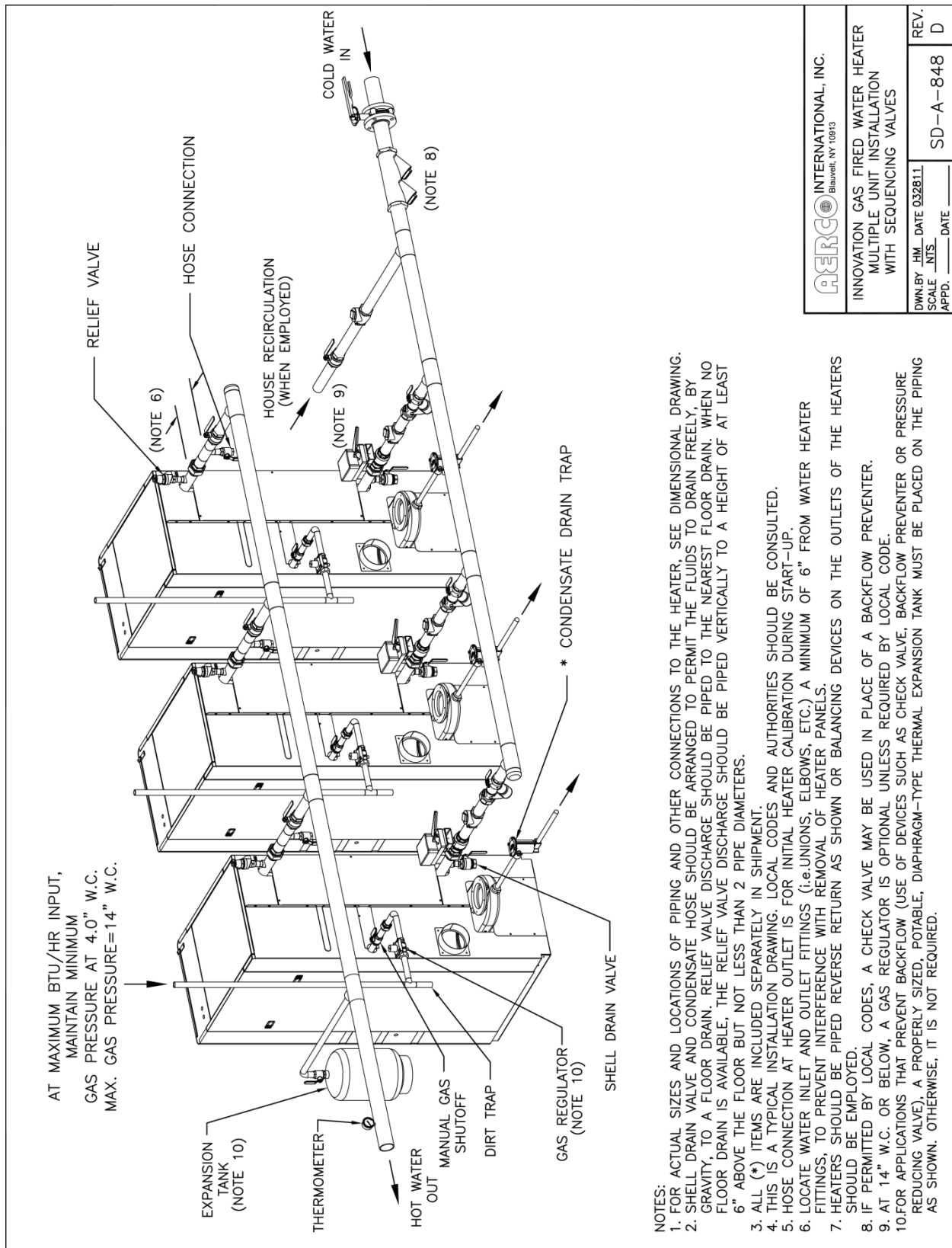
<b>AERCO</b> INTERNATIONAL, INC. <small>Blauvelt, NY 10913</small>	
INNOVATION GAS FIRED WATER HEATER SINGLE UNIT INSTALLATION TWO TEMP. ZONES	
DWN BY: <u>HM</u> DATE: <u>03/02/11</u>	SD-A-845
SCALE: <u>NIS</u>	REV. <u>C</u>
APPD. _____ DATE _____	

Drawing Number: SD-A-845 rev C



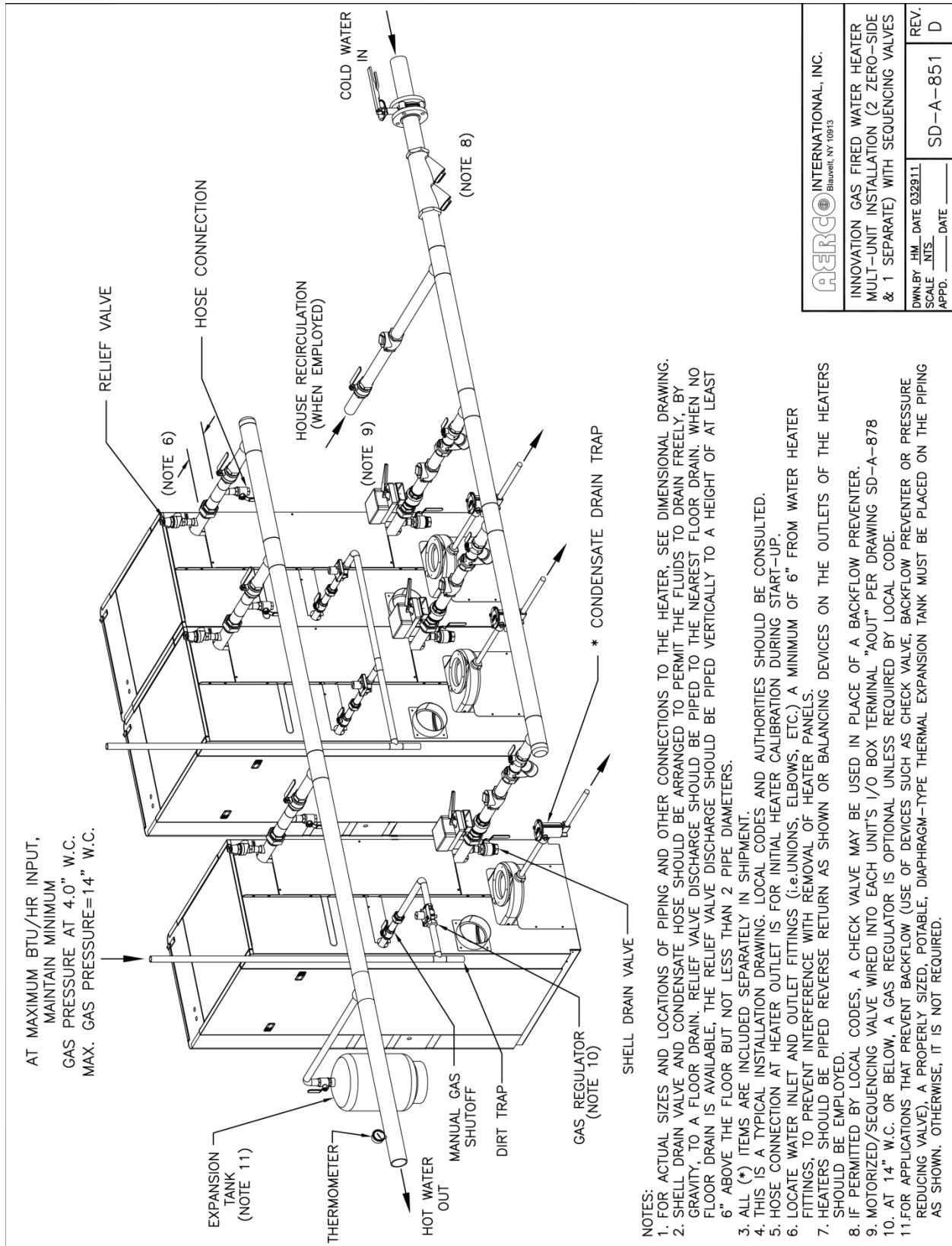
# Innovation Installation, Operation & Maintenance – KOREA EDITION

## APPENDIX F – PIPING DRAWINGS



 AERCO INTERNATIONAL, INC. <small>Blauvelt, NY 10913</small>	
INNOVATION GAS FIRED WATER HEATER MULTIPLE UNIT INSTALLATION WITH SEQUENCING VALVES	
DWN BY: HM DATE 03/28/11 SCALE: NTS. DATE _____ APPD: _____ DATE _____	SD-A-848 REV. D

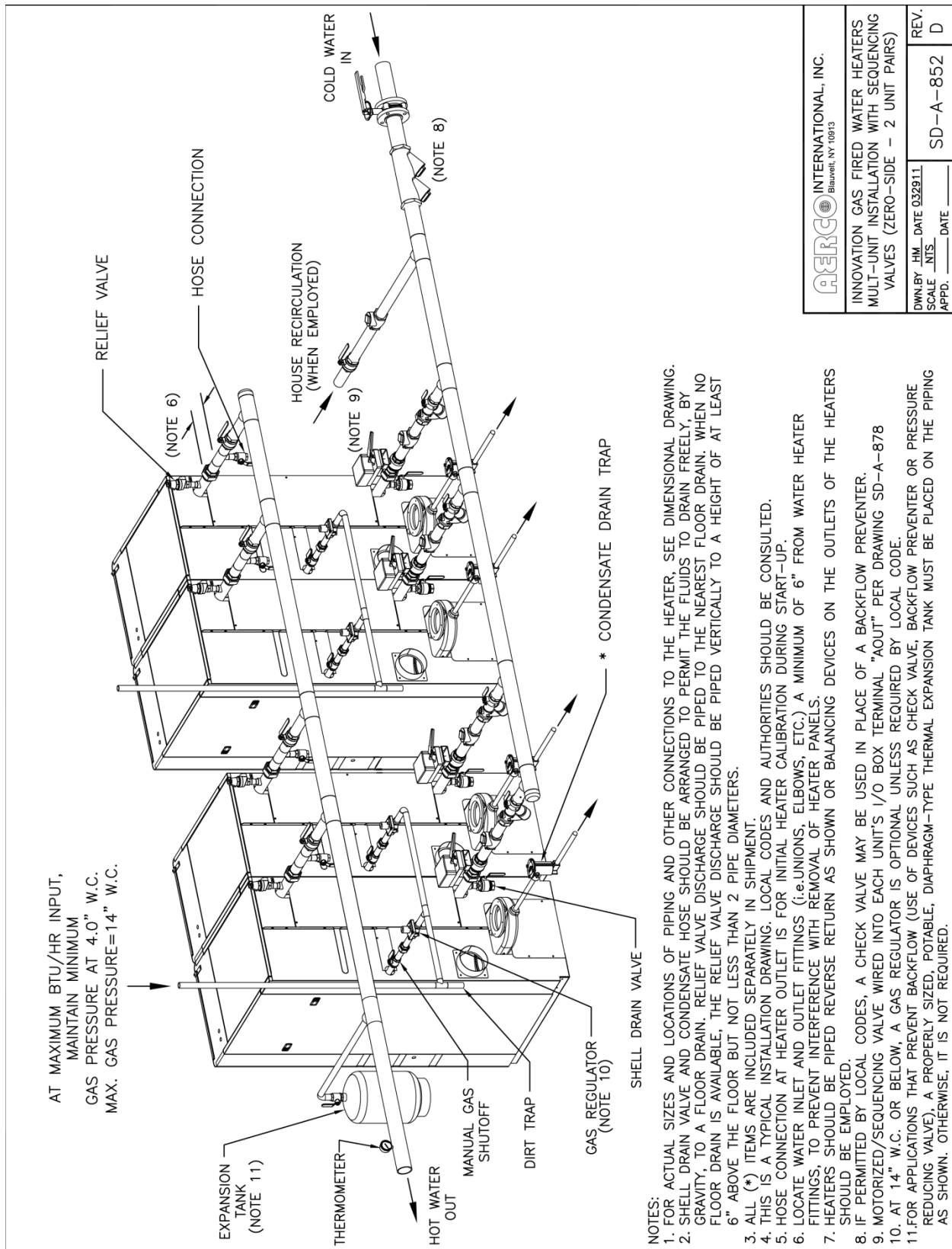
Drawing Number: SD-A-848 rev D



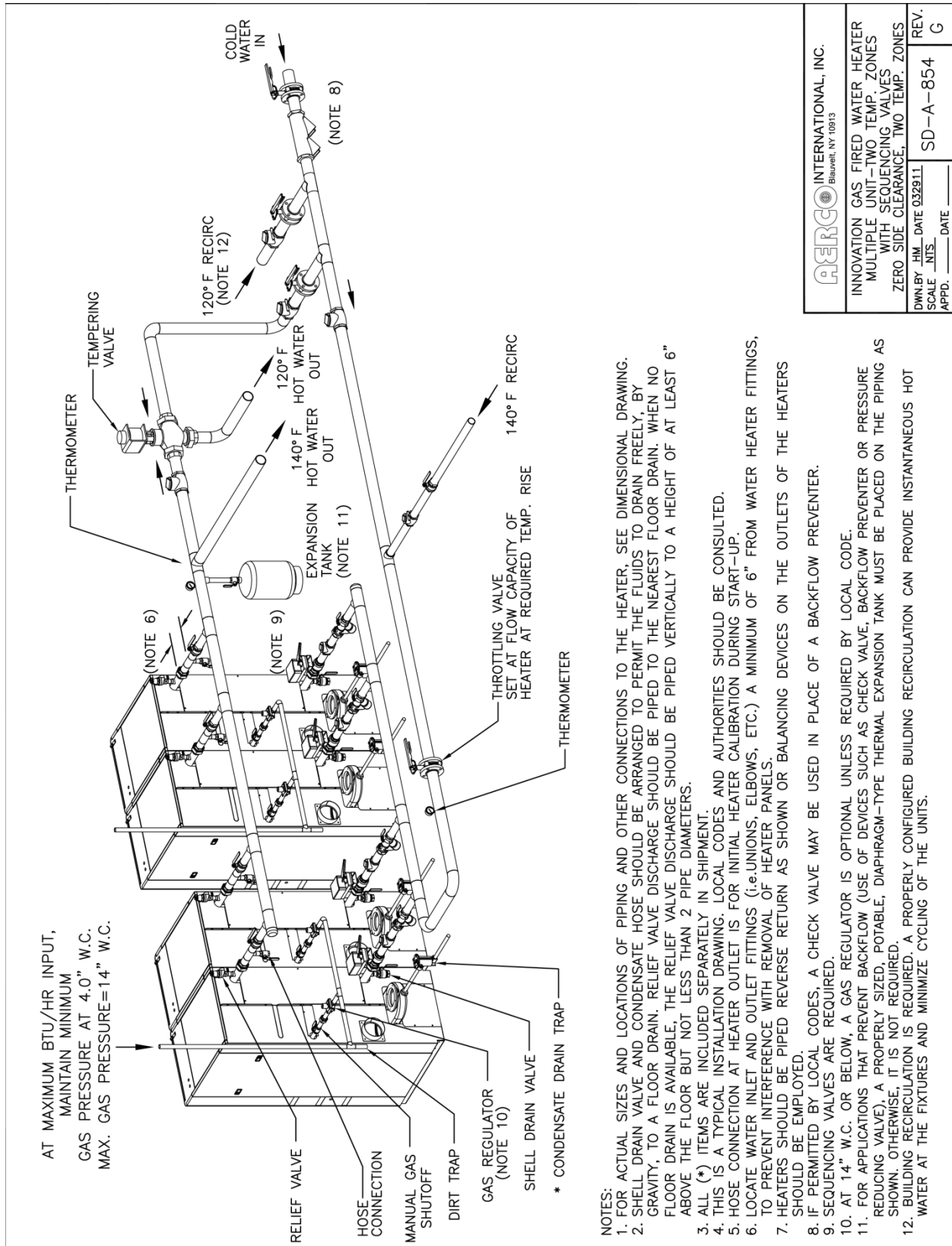
- NOTES:
1. FOR ACTUAL SIZES AND LOCATIONS OF PIPING AND OTHER CONNECTIONS TO THE HEATER, SEE DIMENSIONAL DRAWING.
  2. SHELL DRAIN VALVE AND CONDENSATE HOSE SHOULD BE ARRANGED TO PERMIT THE FLUIDS TO DRAIN FREELY, BY GRAVITY, TO A FLOOR DRAIN. RELIEF VALVE DISCHARGE SHOULD BE PIPED TO THE NEAREST FLOOR DRAIN. WHEN NO FLOOR DRAIN IS AVAILABLE, THE RELIEF VALVE DISCHARGE SHOULD BE PIPED VERTICALLY TO A HEIGHT OF AT LEAST 6" ABOVE THE FLOOR BUT NOT LESS THAN 2 PIPE DIAMETERS.
  3. ALL (\*) ITEMS ARE INCLUDED SEPARATELY IN SHIPMENT.
  4. THIS IS A TYPICAL INSTALLATION DRAWING. LOCAL CODES AND AUTHORITIES SHOULD BE CONSULTED.
  5. HOSE CONNECTION AT HEATER OUTLET IS FOR INITIAL HEATER CALIBRATION DURING START-UP.
  6. LOCATE WATER INLET AND OUTLET FITTINGS (i.e. UNIONS, ELBOWS, ETC.) A MINIMUM OF 6" FROM WATER HEATER FITTINGS, TO PREVENT INTERFERENCE WITH REMOVAL OF HEATER PANELS.
  7. HEATERS SHOULD BE PIPED REVERSE RETURN AS SHOWN OR BALANCING DEVICES ON THE OUTLETS OF THE HEATERS SHOULD BE EMPLOYED.
  8. IF PERMITTED BY LOCAL CODES, A CHECK VALVE MAY BE USED IN PLACE OF A BACKFLOW PREVENTER.
  9. MOTORIZED/SEQUENCING VALVE WIRED INTO EACH UNIT'S I/O BOX TERMINAL "AOUT" PER DRAWING SD-A--878
  10. AT 14" W.C. OR BELOW, A GAS REGULATOR IS OPTIONAL UNLESS REQUIRED BY LOCAL CODE.
  11. FOR APPLICATIONS THAT PREVENT BACKFLOW (USE OF DEVICES SUCH AS CHECK VALVE, BACKFLOW PREVENTER OR PRESSURE REDUCING VALVE), A PROPERLY SIZED, POTABLE, DIAPHRAGM-TYPE THERMAL EXPANSION TANK MUST BE PLACED ON THE PIPING AS SHOWN. OTHERWISE, IT IS NOT REQUIRED.

 Blauvelt, NY 10913	
INNOVATION GAS FIRED WATER HEATER MULTI-UNIT INSTALLATION (2 ZERO-SIDE & 1 SEPARATE) WITH SEQUENCING VALVES	
DWN BY: HM DATE 032911 SCALE: NTS APPD: _____ DATE _____	REV. D SD-A-851

Drawing Number: SD-A-851 rev D



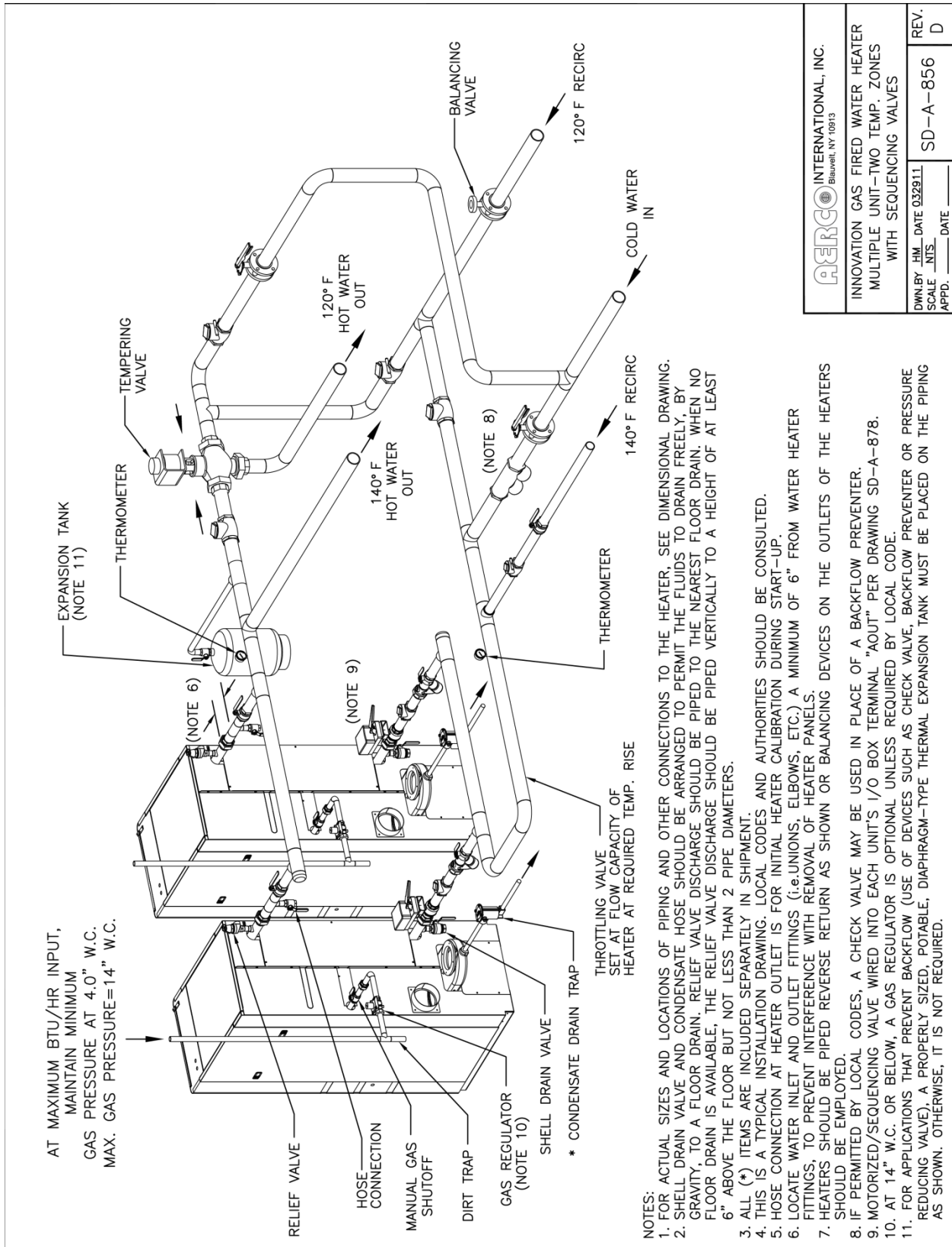
Drawing Number: SD-A-852 rev D



AERCO INTERNATIONAL, INC. Blauvelt, NY 10913	
INNOVATION GAS FIRED WATER HEATER MULTIPLE UNIT-TWO TEMP.-ZONES WITH SEQUENCING VALVES ZERO SIDE CLEARANCE, TWO TEMP. ZONES	
DWN BY: HM APPD: _____	DATE: 03/29/11 DATE: _____
SD-A-854	REV. G

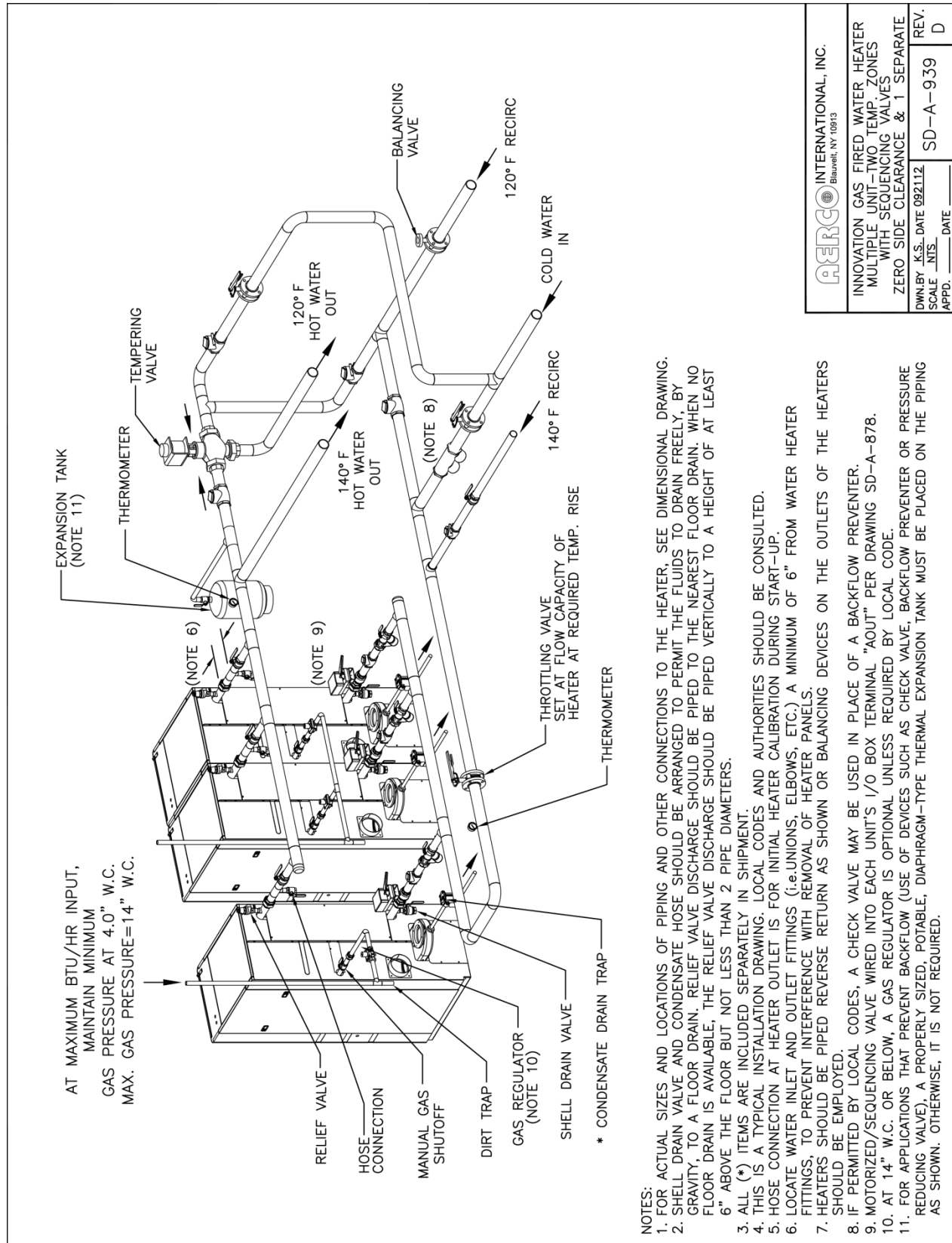
Drawing Number: SD-A-854 rev G





 INTERNATIONAL, INC. <small>Blauvelt, NY 10913</small>	
INNOVATION GAS FIRED WATER HEATER MULTIPLE UNIT—TWO TEMP. ZONES WITH SEQUENCING VALVES	
DWN. BY: HM DATE 03/29/11 SCALE: INTS. _____ APPD. _____ DATE _____	SD-A-856 REV. D

Drawing Number: SD-A-856 rev D



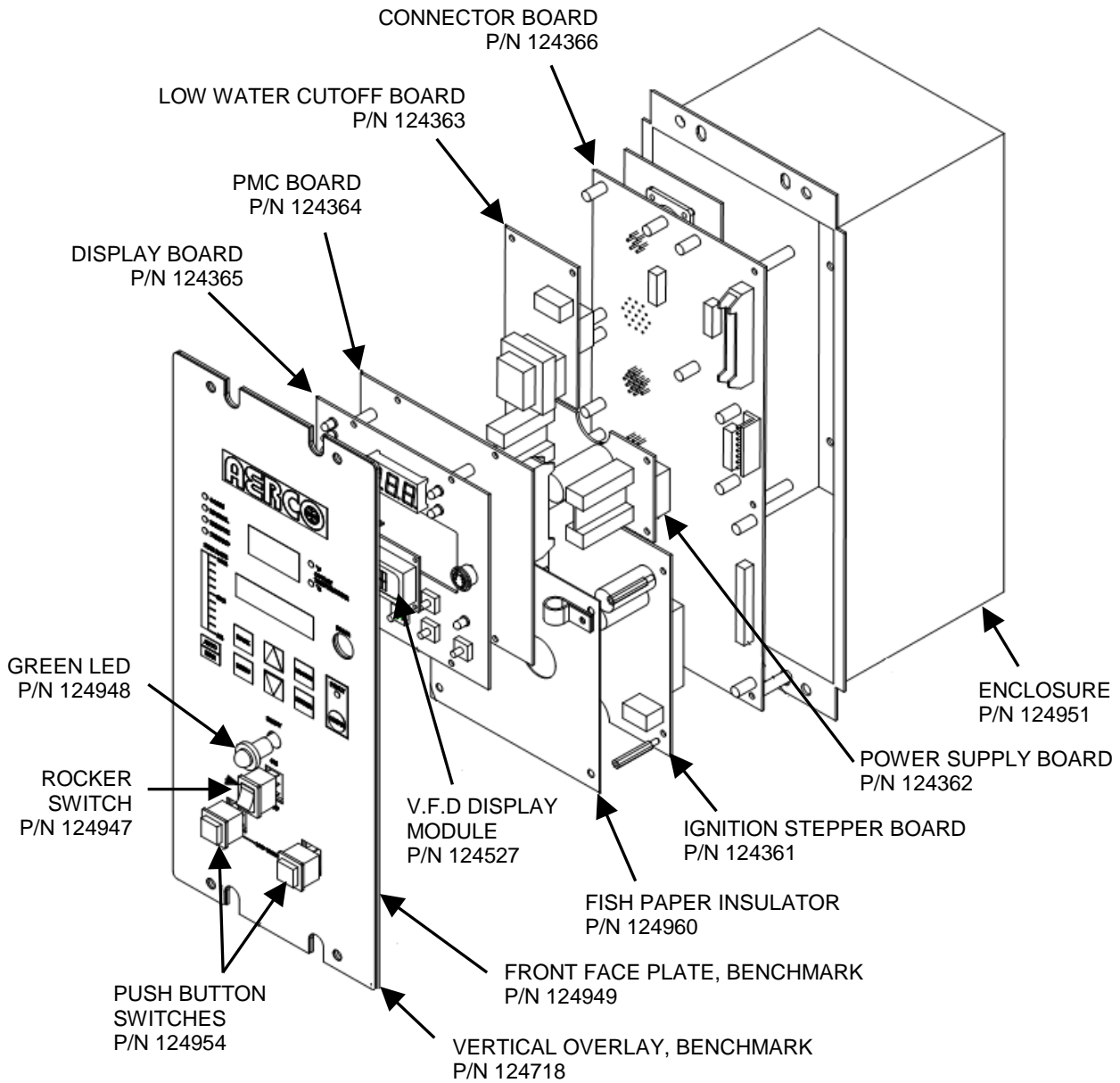
AT MAXIMUM BTU/HR INPUT,  
MAINTAIN MINIMUM  
GAS PRESSURE AT 4.0" W.C.  
MAX. GAS PRESSURE=14" W.C.

- NOTES:
1. FOR ACTUAL SIZES AND LOCATIONS OF PIPING AND OTHER CONNECTIONS TO THE HEATER, SEE DIMENSIONAL DRAWING.
  2. SHELL DRAIN VALVE AND CONDENSATE HOSE SHOULD BE ARRANGED TO PERMIT THE FLUIDS TO DRAIN FREELY, BY GRAVITY, TO A FLOOR DRAIN. RELIEF VALVE DISCHARGE SHOULD BE PIPED TO THE NEAREST FLOOR DRAIN. WHEN NO FLOOR DRAIN IS AVAILABLE, THE RELIEF VALVE DISCHARGE SHOULD BE PIPED VERTICALLY TO A HEIGHT OF AT LEAST 6" ABOVE THE FLOOR BUT NOT LESS THAN 2 PIPE DIAMETERS.
  3. ALL (\*) ITEMS ARE INCLUDED SEPARATELY IN SHIPMENT.
  4. THIS IS A TYPICAL INSTALLATION DRAWING. LOCAL CODES AND AUTHORITIES SHOULD BE CONSULTED.
  5. HOSE CONNECTION AT HEATER OUTLET IS FOR INITIAL HEATER CALIBRATION DURING START-UP.
  6. LOCATE WATER INLET AND OUTLET FITTINGS (i.e. UNIONS, ELBOWS, ETC.) A MINIMUM OF 6" FROM WATER HEATER FITTINGS, TO PREVENT INTERFERENCE WITH REMOVAL OF HEATER PANELS.
  7. HEATERS SHOULD BE PIPED REVERSE RETURN AS SHOWN OR BALANCING DEVICES ON THE OUTLETS OF THE HEATERS SHOULD BE EMPLOYED.
  8. IF PERMITTED BY LOCAL CODES, A CHECK VALVE MAY BE USED IN PLACE OF A BACKFLOW PREVENTER.
  9. MOTORIZED/SEQUENCING VALVE WIRED INTO EACH UNIT'S 1/0 BOX TERMINAL "AOUT" PER DRAWING SD-A-878.
  10. AT 14" W.C. OR BELOW, A GAS REGULATOR IS OPTIONAL UNLESS REQUIRED BY LOCAL CODE.
  11. FOR APPLICATIONS THAT PREVENT BACKFLOW (USE OF DEVICES SUCH AS CHECK VALVE, BACKFLOW PREVENTER OR PRESSURE REDUCING VALVE), A PROPERLY SIZED, POTABLE, DIAPHRAGM-TYPE THERMAL EXPANSION TANK MUST BE PLACED ON THE PIPING AS SHOWN. OTHERWISE, IT IS NOT REQUIRED.

<b>AERCO</b> INTERNATIONAL, INC. <small>Blauvelt, NY 10913</small>	
INNOVATION GAS FIRED WATER HEATER MULTIPLE UNIT-TWO TEMP. ZONES WITH SEQUENCING VALVES ZERO SIDE CLEARANCE & 1 SEPARATE	
DWN.BY: K.S. DATE 092112	SCALE: _____
APPD. _____	DATE _____
REV. _____	SD-A-939
REV. _____	D

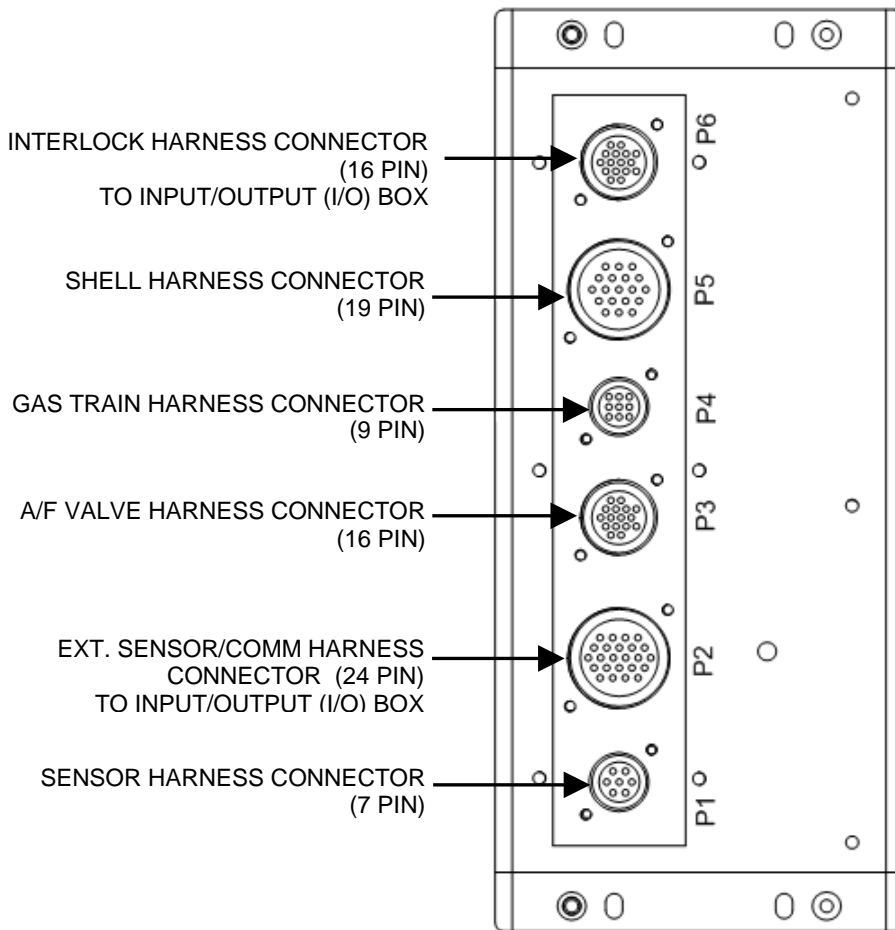
Drawing Number: SD-A-939 rev B

**APPENDIX G – C-More Control Panel Views**



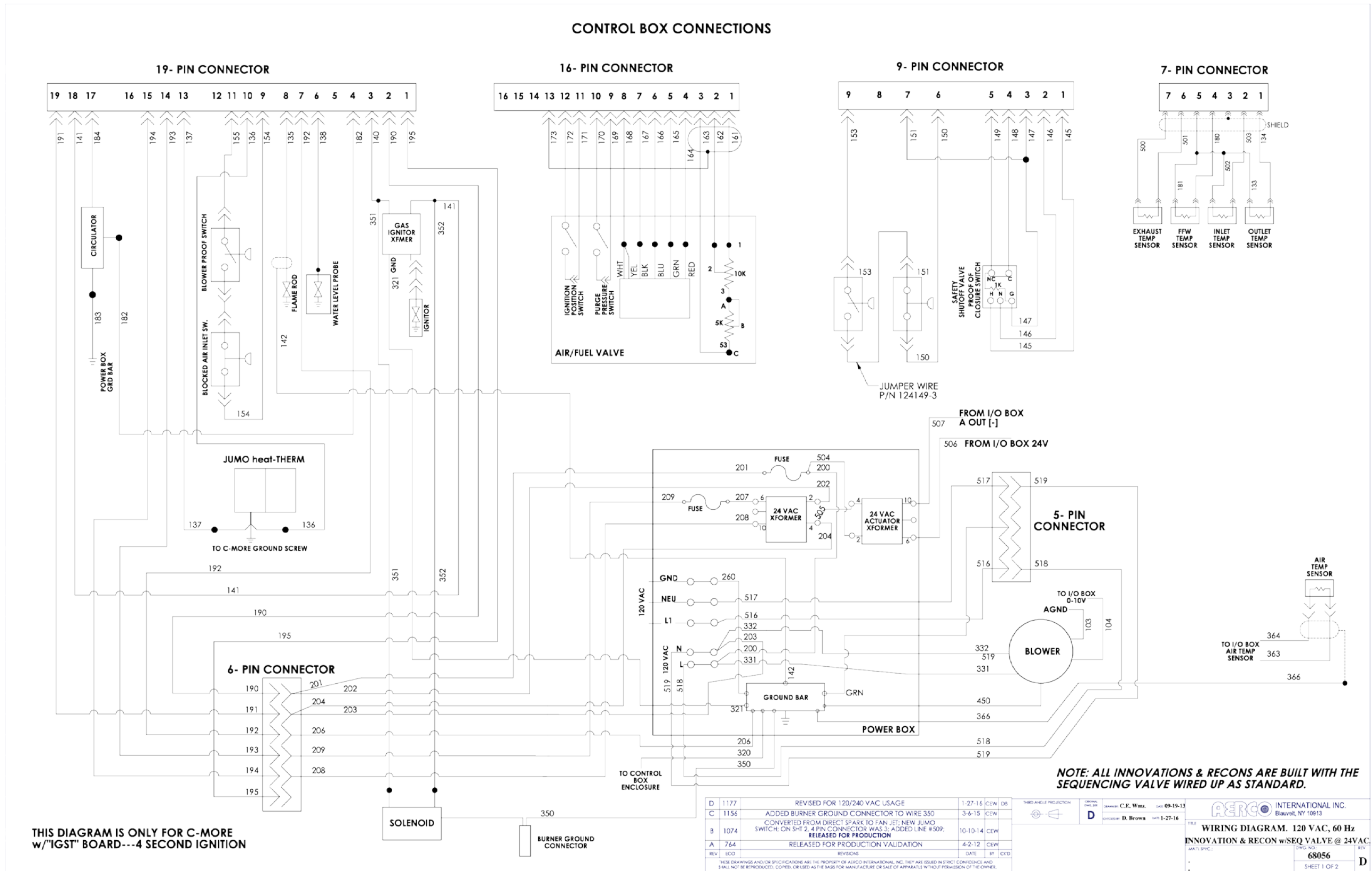
**Figure G-1 – Control Panel - Exploded View**





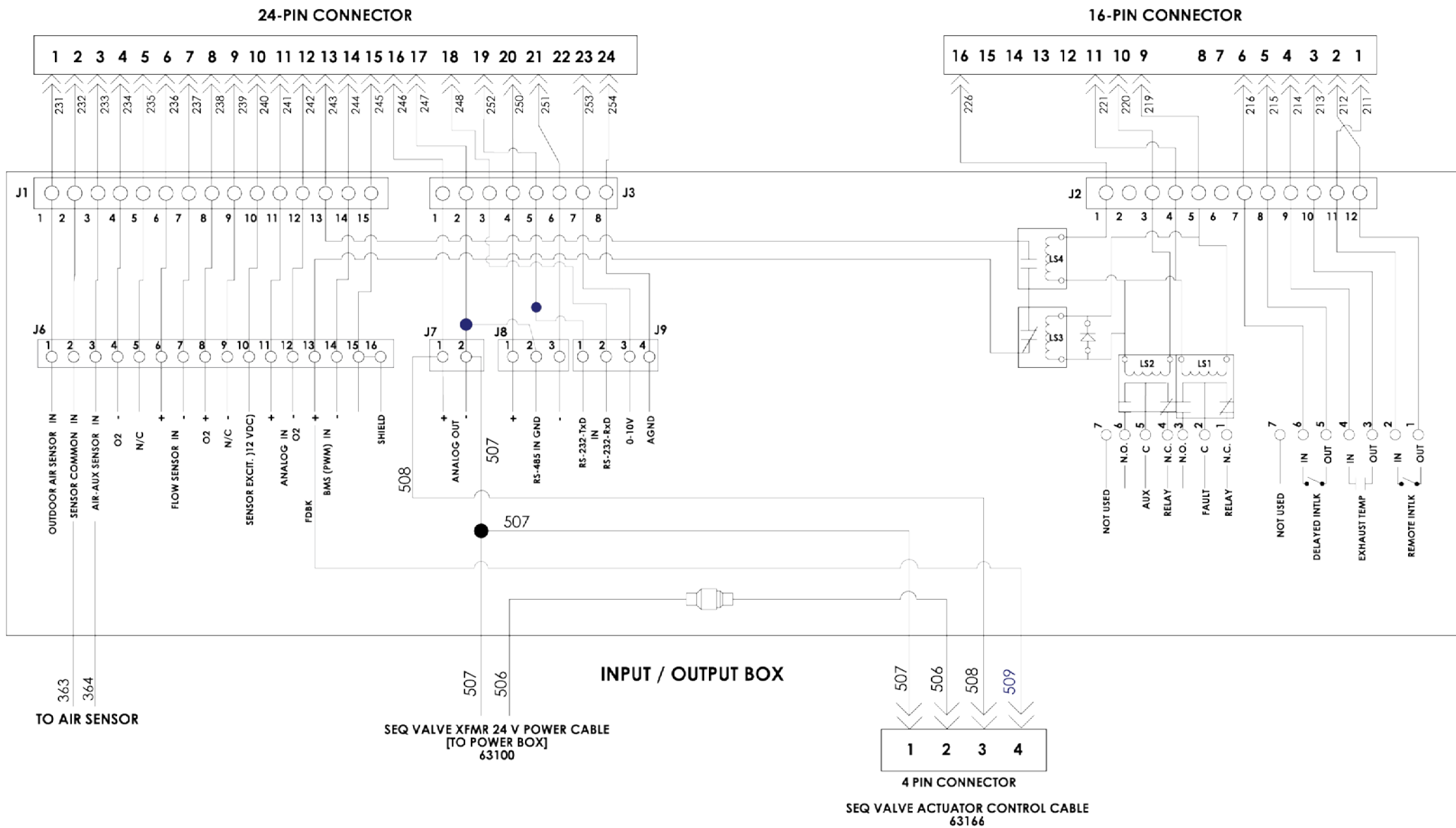
**Figure G-2 – C-MORE CONTROL PANEL REAR VIEW**

**APPENDIX H – C-More Wiring Diagrams**



(This Page Is Intentionally Blank)

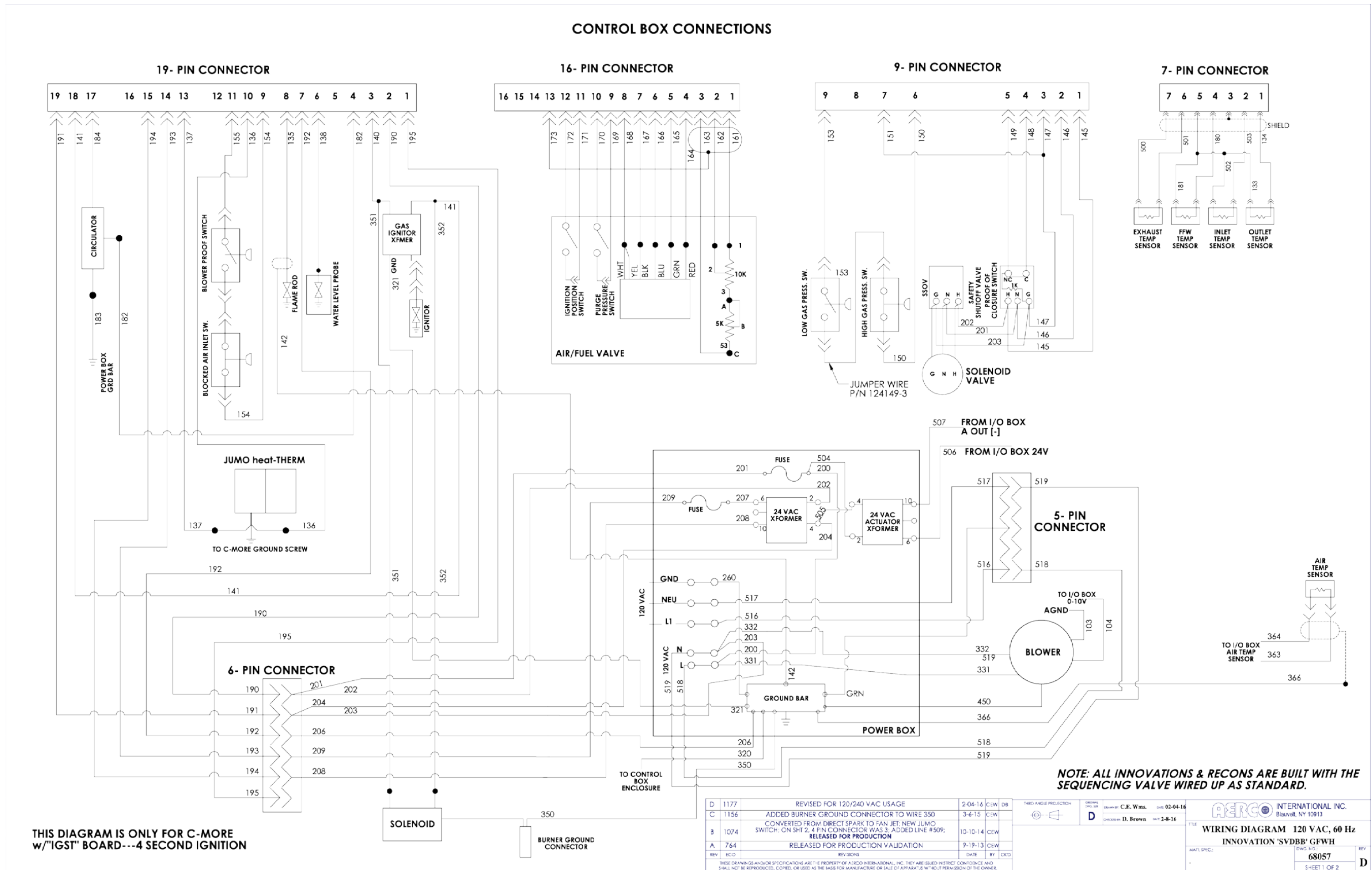
CONTROL BOX CONNECTIONS



Drawing Number: 68056 rev D Sheet 2 of 2

THIRD ANGLE PROJECTION		DATE: 09-19-13	AERCO INTERNATIONAL INC. Blauvelt, NY 10913	
REV	ECO	DATE	BY	CHKD
SEE SHEET 1 OF 2				
THESE DRAWINGS AND/OR SPECIFICATIONS ARE THE PROPERTY OF AERCO INTERNATIONAL, INC. THEY ARE ISSUED IN STRICT CONFIDENCE AND SHALL NOT BE REPRODUCED, COPIED, OR USED AS THE BASIS FOR MANUFACTURE OR SALE OF APPARATUS WITHOUT PERMISSION OF THE OWNER.				
TITLE: WIRING DIAGRAM, 120 VAC, 60 Hz INNOVATION & RECON w/SEQ VALVE @ 24VAC			DRAWING NO: 68056	
SHEET 2 OF 2			REV: D	

(This Page Is Intentionally Blank)

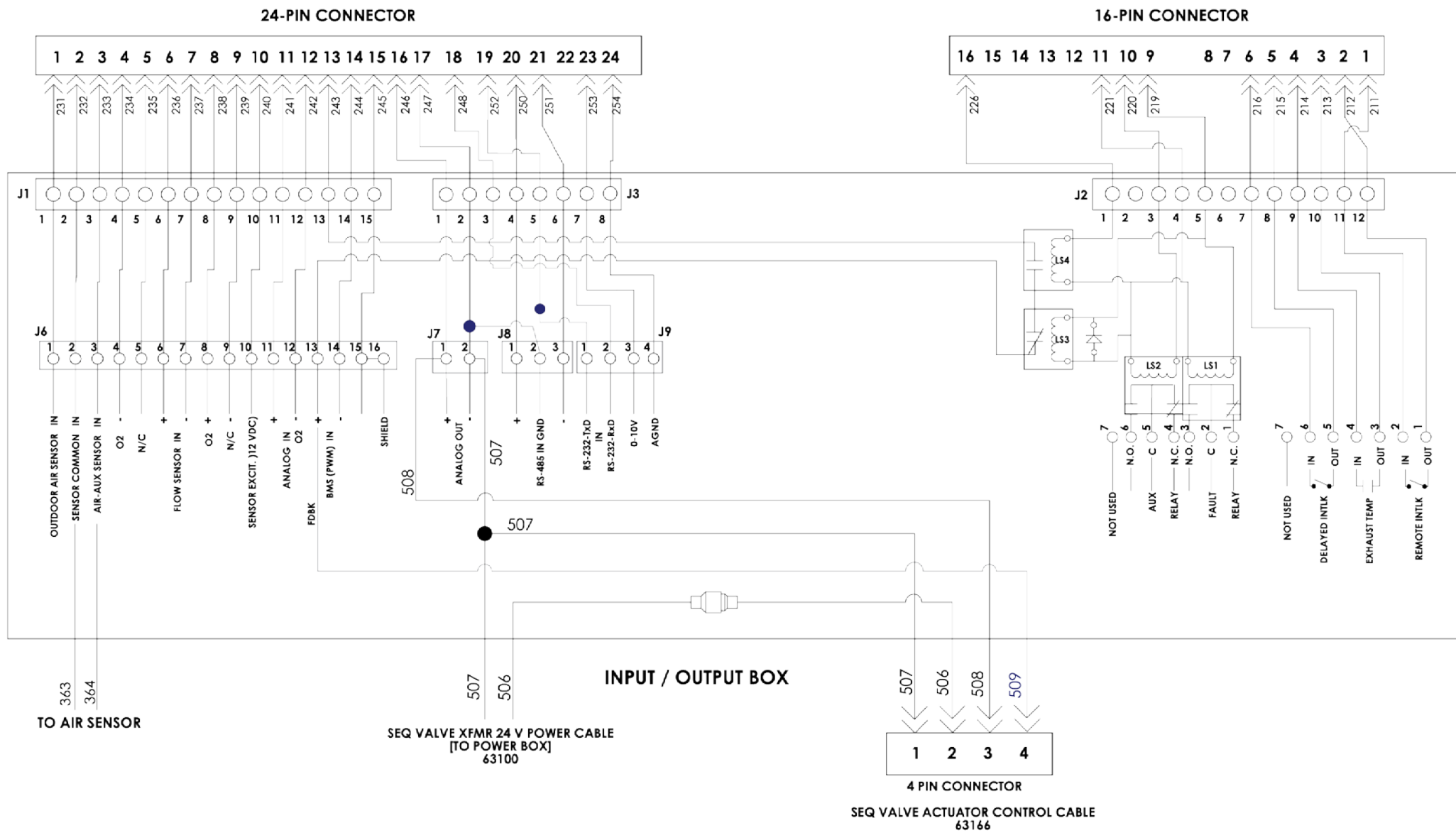


Drawing Number: 68057 rev D Sheet 1 of 2

(This Page Is Intentionally Blank)



CONTROL BOX CONNECTIONS



THIRD ANGLE PROJECTION		DESIGNED BY: C.K. WIEL	DATE: 02-04-16	<p>AERCO INTERNATIONAL INC. Blauvelt, NY 10913</p>
SEE SHEET 1 OF 2		CHECKED BY:	DATE:	
<p>WIRING DIAGRAM 120 VAC, 60 Hz INNOVATION 'SVDBB' GFWH</p>				<p>DWG NO.: 68057 SHEET 2 OF 2</p>
<p>REV: ECO</p>				

Drawing Number: 68057 rev D Sheet 2 of 2

(This Page Is Intentionally Blank)

**APPENDIX I – Recommended Spares**

For the locations of the recommended and optional spare parts listed below, refer to the Parts List Illustrations in Appendix E.

<b>Table I-1. Recommended Emergency Spare Parts</b>		
<b>DESCRIPTION</b>	<b>PART NO.</b>	<b>QUANTITY</b>
120 VAC/Single-Phase Blower	58039	One per three units
SSOV Actuator/Regulator Combo - Used on: <ul style="list-style-type: none"> <li>• ALL FM gas train models</li> <li>• <b>Downstream</b> SSOV on DBB (IRI) gas train models</li> </ul>	64048	One per three units
SSOV Actuator <u>Without</u> Proof of Closure switch: <ul style="list-style-type: none"> <li>• Used <b>ONLY</b> on <b>Upstream</b> SSOV on models with a DBB (IRI) gas train</li> </ul>	27086-1	One per three units
Temperature Sensor (Water & Exhaust)	123449	Three per unit
Flame Detector Kit	24356-2	One kit per unit
Staged Ignition Kit:	58023	One kit per unit

<b>Table I-2. Spare Parts Recommended for Maintenance</b>		
<b>DESCRIPTION</b>	<b>PART NO.</b>	<b>QUANTITY</b>
Annual Maintenance Kit: <ul style="list-style-type: none"> <li>• Staged Ignition– Current</li> <li>• Direct Spark – Older</li> </ul>	58036-01 58036-03	One kit per unit
24-month Waterside/Fireside Inspection Kits: <ul style="list-style-type: none"> <li>• Staged Ignition with air filter</li> <li>• Staged Ignition with filter cleaner (no air filter)</li> <li>• Direct Spark with air filter</li> <li>• Direct Spark with filter cleaner (no air filter)</li> </ul>	58036-02 58036-05 58036-04 58036-06	One kit per unit

## Innovation Installation, Operation & Maintenance – KOREA EDITION

### APPENDIX I – RECOMMENDED SPARES

<b>Table I-3. Optional Spare Parts</b>		
<b>DESCRIPTION</b>	<b>PART NO.</b>	<b>QUANTITY</b>
Circulator Pump, for Dynamic Load Anticipator: <ul style="list-style-type: none"> <li>• Threaded design – current production</li> <li>• Flanged design – older units</li> </ul>	69197 69103	One per site
C-More Controller	69186-2	Stock one if site has difficulty getting parts
Burner Replacement Kit	24335-1	Stock one if site has difficulty getting parts
Air Inlet Temperature Sensor	61024	One per site
Low Gas Pressure Switch: <ul style="list-style-type: none"> <li>• Nat Gas (INN600, INN800, INN1060)</li> <li>• Nat Gas (INN1400)</li> <li>• Propane (All Models)</li> </ul>	61002-1 61002-11 61002-8	One per three units
High Gas Pressure Switch: <ul style="list-style-type: none"> <li>• Nat Gas INN600 to INN1400</li> <li>• Propane INN600 to 1400</li> </ul>	60032 60032	One per three units

**APPENDIX J – Warranty**

**LIMITED WARRANTY: INNOVATION GAS-FIRED WATER HEATER**

---

**PRESSURE VESSEL: 10 YEARS NON-PRORATED**

The shell assembly shall carry a non-prorated 10 year limited warranty from date of shipment against leakage due to thermal shock, water side corrosion, mechanical defects or workmanship.

**HEAT EXCHANGER TUBES/COMBUSTION CHAMBER: 10 YEARS**

The heat exchanger/combustion chamber shall carry a 10 year prorated, limited warranty from date of shipment against any condensate corrosion, thermal stress failure, mechanical defects or workmanship. Operation of the heater using contaminated air will void the warranty. The heat exchangers combustion chamber shall not be warranted from failure due to scaling, liming, corrosion, or erosion due to water or installation conditions. **AERCO** will repair, rebuild or exchange, at its option the heat exchanger/combustion chamber according to the following schedule:

<u>Year</u>	<u>Discount From Then Prevailing List Price</u>
5	100%
6	70%
7	60%
8	50%
9	40%
10	30%

**“C-MORE” CONTROL PANEL: 2 YEARS FROM SHIPMENT**

**AERCO** labeled control panels are conditionally warranted against failure for (2) two years from shipment.

**OTHER COMPONENTS: 18 MONTHS FROM SHIPMENT**

All other components, with the exception of the igniter and flame detector, are conditionally guaranteed against any failure for 18 months from shipment.

(CONTINUED)

### LIMITED WARRANTY: INNOVATION GAS-FIRED WATER HEATER

---

The warranty as set forth on the back page of the Operations & Maintenance Manual is in lieu of and not in addition to any other express or implied warranties in any documents, or under any law. No salesman or other representative of **AERCO** has any authority to expand warranties beyond the face of the said warranty and purchaser shall not rely on any oral statement except as stated in the said warranty. An Officer of AERCO must do any modifications to this warranty in writing. **AERCO MAKES NO WARRANTY OF MERCHANTABILITY OR FITNESS FOR PARTICULAR PURPOSE OR ANY OTHER EXPRESS OR IMPLIED WARRANTIES.** AERCO disclaims all responsibility for any special, incidental or consequential damages. Any claim relating to the product must be filed with **AERCO** not later than 14 days after the event-giving rise to such claim. Any claims relating to this product shall be limited to the sale price of the product at the time of sale. The sale of the product is specifically conditioned upon acceptance of these terms.

#### CONDITIONS OF WARRANTY:

Should an **AERCO** gas-fired (natural gas, propane, and natural gas/propane dual fuel only) water heater fail for any of the above reasons within the specified time period from the date of original shipment(s), AERCO shall at its option modify, repair or exchange the defective item. **AERCO** shall have the option of having the item returned, FOB its factory, or to make field replacements at the point of installation. **In no event shall AERCO be held liable for replacement labor charges** or for freight or handling charges.

**AERCO** shall accept no responsibility if such item has been improperly installed, operated, or maintained – as defined in AERCO OMM manual, or if the buyer has permitted any unauthorized modification, adjustment, and/or repairs to the item. The use of replacement parts not manufactured or sold by **AERCO** will void any warranty, express or limited.

**AERCO** shall accept no responsibility if such item has been damaged due to contaminated combustion air containing but not limited to sheetrock particles, plaster board particles, dirt, dust, lint, and corrosive chemicals such as chlorine gas, halogenated hydrocarbons, and Freon.

In order to process a warranty claim a formal purchase order number is required prior to shipment of any warranty item. In addition, the returned item must include a Returned Goods Authorization (RGA) label, attached to the shipping carton, which identifies the item's return address, register number and factory authorized RGA number.

Warranty coverage for all components and equipment mentioned in said warranty are not valid unless the water heater is started up by a factory certified SST (Service, Start-Up and Troubleshooting) Technician and an AERCO start-up sheet is completed.

This warranty applies only to units sold to customers in North America.

Rev. 09/10/2015

**NOTES:**



Change Log:		
Date	Description	Changed By
06/14/2017	<b>Rev A:</b> Initial Release	
12/20/2017	<b>Rev B:</b> <b>DIR 17-070:</b> Removed manufacturer name from high gas pressure switch <b>DIR 17-080:</b> Verified and corrected part numbers and part diagrams in Appendix E. <b>DIR 17-086:</b> Removed plastic condensate trap from Sections 2.9 and 6.9 (ref PIR 1484).	Chris Blair



© AERCO International, Inc., 2017